



BSR/ASHRAE Standard 223P

Public Review Draft

Semantic Data Model for Analytics and Automation Applications in Buildings

**Second Publication Public Review (April 2026)
(Draft Shows Proposed Independent Substantive Changes to Previous Public
Review Draft)**

This draft has been recommended for public review by the responsible project committee. To submit a comment on this proposed standard, go to the ASHRAE website at www.ashrae.org/standards-research-technology/public-review-drafts and access the online comment database. The draft is subject to modification until it is approved for publication by the Board of Directors and ANSI. Until this time, the current edition of the standard (as modified by any published addenda on the ASHRAE website) remains in effect. The current edition of any standard may be purchased from the ASHRAE Online Store at www.ashrae.org/bookstore or by calling 404-636-8400 or 1-800-727-4723 (for orders in the U.S. or Canada).

The appearance of any technical data or editorial material in this public review document does not constitute endorsement, warranty, or guaranty by ASHRAE of any product, service, process, procedure, or design, and ASHRAE expressly disclaims such.

© 2026 ASHRAE. This draft is covered under ASHRAE copyright. Permission to reproduce or redistribute all or any part of this document must be obtained from the ASHRAE Manager of Standards, 180 Technology Parkway NW, Peachtree Corners, GA 30092. Phone: 404-636-8400, Ext. 1125. Fax: 404-321-5478. E-mail: standards.section@ashrae.org.

ASHRAE, 180 Technology Parkway NW, Peachtree Corners, GA 2009

This is a review of Independent Substantive Changes that were made since the last public review. Areas where substantive changes have been made are highlighted in gray. Other areas are out of scope for the public review but are presented to provide context for the changed portions.

Contents

1 PURPOSE	1
2 SCOPE	1
3 DEFINITIONS.....	2
3.1 Terms Defined for this Standard.....	2
3.2 Abbreviations and Acronyms Used in this Standard	3
4 CONCEPTUAL FRAMEWORK FOR SEMANTIC MODELING OF BUILDING SYSTEMS AND DATA.....	3
4.1 Conformance Constraints and Validation.....	5
4.2 Deriving Implicit Information from Inference Rules.....	6
4.3 Textual Serialization	6
4.4 Units of Measure.....	6
4.5 Namespace	6
4.6 s223:Concept.....	7
4.6.1 s223:Class	7
4.6.2 s223:Relation	8
4.7 s223:hasProperty.....	8
5 EQUIPMENT	9
5.1 s223:Equipment	9
5.2 Equipment Containment	10
5.3 s223:contains.....	11
5.4 s223:hasRole.....	11
5.5 s223:hasPhysicalLocation.....	11
5.6 s223:Sensor	11
5.6.1 s223:ConcentrationSensor	12
5.6.2 s223:ElectricCurrentSensor	13
5.6.3 s223:FlowSensor.....	13
5.6.4 s223:HumiditySensor.....	13
5.6.5 s223:LightSensor	13
5.6.6 s223:OccupancySensor	14
5.6.7 s223:ParticulateSensor.....	15

5.6.8 s223:PressureSensor	15
5.6.9 s223:TemperatureSensor.....	16
5.6.10 s223:VoltageSensor	16
5.6.11 s223:hasMeasurementResolution	16
5.6.12 s223:observes	16
5.6.13 s223:hasObservationLocation.....	17
5.6.14 s223:hasReferenceLocation	17
5.7 s223:Actuator	17
5.7.1 s223:actuates	17
5.7.2 s223:actuatedByProperty	17
5.8 s223:Controller	17
5.8.1 s223:Function.....	18
5.8.2 s223:executes	18
6 CONNECTION.....	18
6.1 s223:Connectable.....	18
6.2 s223:ConnectionPoint	19
6.2.1 s223:BidirectionalConnectionPoint	21
6.2.2 s223:InletConnectionPoint.....	22
6.2.3 s223:OutletConnectionPoint	22
6.2.4 s223:pairedConnectionPoint	22
6.2.5 s223:mapsTo	23
6.2.6 s223:hasMedium	23
6.3 s223:Connection	23
6.3.1 s223:EM.....	25
6.3.2 s223:Pipe.....	25
6.3.3 s223:Duct	26
6.3.4 s223:Conductor	26
6.3.5 s223:Waveguide.....	27
6.4 s223:Junction	28
6.5 Relations Describing Connectedness.....	29
6.5.1 s223:connected.....	31
6.5.2 s223:connectedTo	31
6.5.3 s223:connectedFrom	31
6.5.4 s223:connectedThrough.....	31

6.5.5 s223:connectsTo	31
6.5.6 s223:connectsFrom	32
6.5.7 s223:connectsThrough	32
6.5.8 s223:connectsAt	32
6.5.9 s223:hasConnectionPoint	32
6.5.10 s223:isConnectionPointOf	32
6.5.11 s223:cnx	32
6.6 s223:hasMedium	32
7 SYSTEM	32
7.1 s223:System	33
7.2 s223:hasMember	33
7.3 s223:hasBoundaryConnectionPoint	33
7.4 s223:hasOptionalConnectionPoint	34
8 SPACE	34
8.1 Physical Space	34
8.1.1 s223:PhysicalSpace	34
8.1.2 s223:encloses	35
8.1.3 s223:OutdoorPhysicalSpace	35
8.2 Domain Space	35
8.2.1 s223:DomainSpace	35
8.2.2 s223:hasDomain	35
9 ZONE	35
9.1 s223:Zone	36
9.2 s223:hasDomainSpace	36
9.3 s223:hasZone	36
10 ENUMERATIONS	36
10.1 s223:EnumerationKind	37
10.2 s223:EnumerationKind-Aspect	37
10.2.1 Equipment Information	37
10.2.2 Equipment Operation	38
10.2.3 Operational Limits	38
10.2.4 Control Parameters	39
10.2.5 Delta Quantities	39
10.3 s223:EnumerationKind-Binary	39

10.3.1 s223:Binary-Logical	39
10.3.2 s223:Binary-OnOff	40
10.3.3 s223:Binary-Position.....	40
10.4 s223:EnumerationKind-DayOfWeek.....	40
10.4.1 s223:DayOfWeek-Weekday	40
10.4.2 s223:DayOfWeek-Weekend	41
10.5 s223:EnumerationKind-Domain.....	41
10.6 s223:EnumerationKind-ElectricalPhaseIdentifier	41
10.6.1 s223:hasElectricalPhase.....	42
10.7 s223:EnumerationKind-Numerical	42
10.7.1 s223:Numerical-Frequency.....	42
10.7.2 s223:Numerical-NumberOfElectricalPhases	43
10.7.3 s223:Numerical-Voltage	43
10.8 s223:EnumerationKind-Occupancy	44
10.8.1 s223:Occupancy-Motion.....	44
10.8.2 s223:Occupancy-Presence	45
10.8.3 s223:Occupancy-Occupied	45
10.9 s223:EnumerationKind-ThermodynamicPhase	45
10.9.1 s223:ThermodynamicPhase-Gas.....	45
10.9.2 s223:ThermodynamicPhase-Liquid	46
10.9.3 s223:hasThermodynamicPhase.....	46
10.10 s223:EnumerationKind-Role	46
10.11 s223:EnumerationKind-Substance.....	47
10.11.1 s223:Substance-Medium.....	47
10.11.2 s223:Substance-Particulate	69
10.11.3 s223:Substance-Soot.....	70
11 PROPERTIES AND VALUES.....	70
11.1 s223:Property	71
11.2 s223:ActuatableProperty.....	73
11.3 s223:ObservableProperty	74
11.4 s223:EnumerableProperty.....	74
11.4.1 s223:hasEnumerationKind.....	74
11.5 s223:QuantifiableProperty	74
11.5.1 s223:hasAlarmStatus.....	77

11.5.2 s223:hasDeadband	77
11.5.3 s223:hasSetpoint	77
11.5.4 s223:hasThreshold	77
11.6 s223:QuantifiableActuatableProperty	77
11.7 s223:QuantifiableObservableProperty	77
11.8 s223:EnumeratedObservableProperty	77
11.9 s223:EnumeratedActuatableProperty	77
11.10 s223:hasValue	78
11.11 qudt:hasUnit	78
11.12 qudt:hasQuantityKind	78
11.13 s223:hasAspect	78
11.14 s223:ofSubstance	78
11.15 s223:ofMedium	78
11.16 s223:ofConstituent	78
11.17 s223:composedOf	79
11.18 s223:ExternalReference	79
11.18.1 s223:BACnetExternalReference	79
11.19 s223:hasExternalReference	80
11.20 s223:hasInternalReference	80
11.21 s223:isInternalReferenceOf	82
12 REFERENCE FOR EQUIPMENT	83
12.1 s223:AirHandlingUnit	83
12.2 s223:AirHeatExchanger	84
12.3 s223:Battery	84
12.4 s223:Boiler	85
12.5 s223:ChilledBeam	85
12.6 s223:Chiller	85
12.7 s223:ClothesWasher	85
12.8 s223:CoffeeMaker	86
12.9 s223:Coil	86
12.9.1 s223:CoolingCoil	87
12.9.2 s223:HeatingCoil	87
12.10 s223:Compressor	88
12.11 s223:Computer	88

12.11.1 s223:PersonalComputer	88
12.11.2 s223:ServerComputer	88
12.12 s223:ComputerPrinter	89
12.13 s223:CoolingTower.....	89
12.14 s223:CopyMachine	89
12.15 s223:Damper	89
12.16 s223:Dishwasher	90
12.17 s223:Door.....	90
12.18 s223:ElectricityBreaker.....	90
12.19 s223:ElectricClothesDryer	91
12.20 s223:ElectricCooktop.....	91
12.21 s223:ElectricEnergyConverter	91
12.21.1 s223:ElectricEnergyDCDCConverter	91
12.21.2 s223:ElectricEnergyInverter	92
12.21.3 s223:ElectricEnergyTransformer	92
12.22 s223:ElectricityMeter.....	92
12.23 s223:ElectricityOutlet	93
12.24 s223:ElectricOven.....	93
12.25 s223:ElectricResistanceElement	93
12.26 s223:ElectricWaterDispenser.....	94
12.27 s223:ElectronicDisplay	94
12.27.1 s223:Monitor.....	95
12.27.2 s223:Television	95
12.28 s223:Elevator	95
12.29 s223:Escalator	95
12.30 s223:EthernetSwitch	95
12.31 s223:EthernetPort.....	96
12.32 s223:Fan	96
12.33 s223:FanCoilUnit.....	96
12.34 s223:FiberEthernetOutlet.....	97
12.35 s223:Filter	97
12.36 s223:FlushToilet	97
12.37 s223:Freezer	98
12.38 s223:FumeHood.....	98

12.39 s223:Furnace	98
12.40 s223:Generator	98
12.41 s223:HeatPump	99
12.41.1 s223:AirToAirHeatPump	99
12.41.2 s223:GroundToAirHeatPump	99
12.41.3 s223:WaterToAirHeatPump	99
12.41.4 s223:WaterToWaterHeatPump	99
12.42 s223:Humidifier	100
12.43 s223:Humidistat	100
12.44 s223:HydronicHeatExchanger	100
12.45 s223:IceMaker	100
12.46 s223:Luminaire	101
12.47 s223:MicrowaveOven	101
12.48 s223:Motor	101
12.49 s223:PhotovoltaicModule	101
12.50 s223:PowerOverEthernetSwitch	102
12.51 s223:PowerOverEthernetPort	102
12.52 s223:Pump	102
12.53 s223:RadiantHeater	103
12.54 s223:Radiator	104
12.55 s223:Refrigerator	104
12.56 s223:RFOutlet	104
12.57 s223:Sink	104
12.58 s223:SolarThermalCollector	105
12.59 s223:SteamInjector	105
12.60 s223:TerminalUnit	105
12.60.1 s223:DualDuctTerminal	105
12.60.2 s223:FanPoweredTerminal	106
12.60.3 s223:SingleDuctTerminal	106
12.61 s223:ThermalEnergyStorageUnit	107
12.62 s223:Thermostat	107
12.63 s223:Turbine	107
12.64 s223:USBOutlet	107
12.65 s223:Valve	107

12.65.1 s223:Drain.....	108
12.65.2 s223:Faucet	108
12.65.3 s223:ThreeWayValve	108
12.65.4 s223:TwoWayValve	109
12.66 s223:VariableFrequencyDrive	110
12.67 s223:WaterOutlet	110
12.68 s223:Window	110
12.69 s223:WindowShade	111
12.70 s223:WiredEthernetOutlet	111
Annex A - RDF REPRESENTATION OF THIS STANDARD (NORMATIVE).....	111
Annex B - ASHRAE GUIDELINE 36 EXTENSION (INFORMATIVE).....	111
Annex B.1 Model Components.....	112
Annex B.1.1 g36:Damper	112
Annex B.1.2 g36:DamperAnnotation	112
Annex B.1.3 g36:TwoPositionDamper.....	112
Annex B.1.4 g36:TwoPositionDamperAnnotation.....	112
Annex B.1.5 g36:HotWaterCoil	112
Annex B.1.6 g36:HotWaterCoilAnnotation	113
Annex B.1.7 g36:ElectricHeatingCoil	113
Annex B.1.8 g36:ElectricHeatingCoilAnnotation	113
Annex B.1.9 g36:HotWaterValve.....	113
Annex B.1.10 g36:HotWaterValveAnnotation.....	113
Annex B.1.11 g36:ChilledWaterCoil.....	114
Annex B.1.12 g36:ChilledWaterCoilAnnotation.....	114
Annex B.1.13 g36:ChilledWaterValve.....	114
Annex B.1.14 g36:ChilledWaterValveAnnotation	114
Annex B.1.15 g36:Zone.....	114
Annex B.1.16 g36:ZoneAnnotation.....	115
Annex B.1.17 g36:ZoneGroup.....	115
Annex B.1.18 g36:ZoneGroupAnnotation.....	115
Annex B.1.19 g36:Fan	115
Annex B.1.20 g36:FanAnnotation	116
Annex B.1.21 g36:FanWithVFD	116
Annex B.1.22 g36:FanWithVFDAnnotation	116

Annex B.2 VAV Terminal Unit - Cooling Only.....	116
Annex B.2.1 g36:VAVTerminalCoolingOnly.....	116
Annex B.2.2 g36:VAVTerminalCoolingOnlyAnnotation.....	117
Annex B.2.3 Example VAV Terminal Unit - Cooling Only	117
Annex B.3 VAV Terminal Unit with Reheat.....	117
Annex B.3.1 g36:VAVTerminalWithReheat.....	117
Annex B.3.2 g36:VAVTerminalWithReheatAnnotation.....	118
Annex B.3.3 Example VAV Terminal Unit With Reheat	118
Annex B.4 Fan Powered Terminal Unit	118
Annex B.4.1 g36:FanPoweredTerminal	118
Annex B.4.2 g36:FanPoweredTerminalAnnotation	119
Annex B.4.3 Example Fan Powered Terminal Unit	119
Annex B.4.4 Example Parallel Fan Powered Terminal Unit.....	119
Annex B.5 Dual Duct Terminal Unit with Inlet Sensors.....	120
Annex B.5.1 g36:DualDuctTerminalWithInletSensors	120
Annex B.5.2 g36:DualDuctTerminalWithInletSensorsAnnotation	121
Annex B.5.3 Example Dual Duct Terminal Unit With Inlet Sensors.....	121
Annex B.6 Dual Duct Terminal Unit with Discharge Sensor.....	121
Annex B.6.1 g36:DualDuctTerminalWithDischargeSensor.....	121
Annex B.6.2 g36:DualDuctTerminalWithDischargeSensorAnnotation.....	122
Annex B.6.3 Example Dual Duct Terminal Unit With Discharge Sensors	122
Annex B.7 Multiple Zone VAV Air Handling Unit	123
Annex B.7.1 doc:MultipleZoneVAVAirHandlingUnitExample	123
Annex B.7.2 g36:MultipleZoneVAVAirHandlingUnit	123
Annex B.7.3 g36:MultipleZoneVAVAirHandlingUnitAnnotation	123
Annex B.7.4 g36:MultipleZoneVAVAirHandlingUnit-CommonDamper	123
Annex B.7.5 g36:MultipleZoneVAVAirHandlingUnit-CommonDamperAnnotation	124
Annex B.7.6 g36:MultipleZoneVAVAirHandlingUnit-OADandAFMS	124
Annex B.7.7 g36:MultipleZoneVAVAirHandlingUnit-OADandAFMSAnnotation	124
Annex B.7.8 g36:MultipleZoneVAVAirHandlingUnit-OADandDP	124
Annex B.7.9 g36:MultipleZoneVAVAirHandlingUnit-OADandDPAnnotation	125
Annex B.7.10 g36:MultipleZoneVAVAirHandlingUnit-WithReliefDamper	125
Annex B.7.11 g36:MultipleZoneVAVAirHandlingUnit-WithReliefDamperAnnotation ..	125
Annex B.7.12 g36:MultipleZoneVAVAirHandlingUnit-WithReliefFan	125

Annex B.7.13 g36:MultipleZoneVAVAirHandlingUnit-WithReturnFan	125
Annex B.7.14 g36:SingleZoneVAVAirHandlingUnit-WithReliefDamper.....	126
Annex B.7.15 Example Multiple Zone VAV Air Handling Unit.....	126
Annex B.8 Dual Fan Dual Duct Air Handling Unit.....	127
Annex B.8.1 g36:DualFanDualDuctAirHandlingUnit	127
Annex B.8.2 g36:DualFanDualDuctAirHandlingUnitAnnotation	128
Annex B.8.3 Example Dual Fan Dual Duct Air Handling Unit.	128
Annex B.9 Single Zone VAV Air Handling Unit.....	128
Annex B.9.1 g36:SingleZoneVAVAirHandlingUnit.....	128
Annex B.9.2 g36:SingleZoneVAVAirHandlingUnitAnnotation.....	129
Annex B.9.3 g36:SingleZoneVAVAirHandlingUnit-NoReliefFan.....	129
Annex B.9.4 g36:SingleZoneVAVAirHandlingUnit-NoReliefFanAnnotation.....	129
Annex B.9.5 g36:SingleZoneVAVAirHandlingUnit-WithReliefFan.....	129
Annex B.9.6 g36:SingleZoneVAVAirHandlingUnit-WithReliefFanAnnotation.....	130
Annex B.9.7 g36:SingleZoneVAVAirHandlingUnit-WithReturnFan	130
Annex B.9.8 g36:SingleZoneVAVAirHandlingUnit-WithReturnFanAnnotation	130
Annex B.9.9 Example Single Zone VAV Air Handling Unit Unit	130

(This foreword is not part of this standard. It is merely informative and does not contain requirements necessary for conformance to the standard. It has not been processed according to the ANSI requirements for a standard and may contain material that has not been subject to public review or a consensus process. Unresolved objectors on informative material are not offered the right to appeal at ASHRAE or ANSI.)

FOREWORD

The motivation for this standard is to facilitate the deployment and use of software tools that leverage the data available from building automation systems to improve building system operation in a variety of ways. This standard builds upon standards and tools developed by the World Wide Web Consortium (W3C). Using those general tools, this standard defines modeling constructs for use in creating machine-readable representations of building systems, the building spaces that they serve, and the measurement and control points used to provide a safe and comfortable environment for the building occupants. The result is a searchable knowledge graph that can be used to automate the data mapping and configuration needed to deploy analytical, management, and control tools for the built environment.

Additional material is available at <http://open223.info> that may be helpful in using this standard including:

- *An online user's guide;*
- *Example models;*
- *A query interface to try generating queries of the example models; and*
- *Tools for exploring the Standard 223P ontology.*

1 PURPOSE

The purpose of this standard is to define formal knowledge concepts and a methodology to apply them to create interoperable, machine-readable semantic frameworks for representing building automation and control data, and other building system information.

2 SCOPE

This standard provides a comprehensive way to apply semantic formalisms to represent the context of building system data and relationships between the associated building mechanical system components so that software applications can find and understand the information in an automated way. It is intended to facilitate the development and implementation of building analytics tools and enterprise knowledge applications that can implement many building system functions, including:

- (a) automated fault detection and diagnostics,
- (b) building system commissioning,
- (c) digital twins,
- (d) optimization of energy use, and
- (e) smart grid interactions.

3 DEFINITIONS

3.1 Terms Defined for this Standard

Connectable: an abstract class that represents a thing (Equipment, DomainSpace or Junction) that can be connected via connection points and connections.

Connection: the modeling construct used to represent a physical thing (e.g., pipe, duct, or conductor) that is used to convey some Substance-Medium (e.g., water, air, or electricity) between two Connectable things.

ConnectionPoint: an abstract modeling construct used to represent the fact that one Connectable thing can be connected to another Connectable thing using a Connection. It is the abstract representation of the flange, wire terminal, or other physical feature where a connection is made.

Domain: a categorization of building service or specialization used to characterize equipment or spaces in a building. Example domains include HVAC, lighting, and plumbing.

DomainSpace: a portion or the entirety of a PhysicalSpace that is associated with a EnumerationKind-Domain, such as lighting, HVAC, or physical security. DomainSpaces can be combined to form a Zone.

Equipment: the modeling construct used to represent a device designed to accomplish a specific task. Examples include a pump, fan, heat exchanger, luminaire, temperature sensor, or flow meter. Both Equipment and System can be used to associate multiple pieces of Equipment with a higher-level concept. See Clause 5 and Clause 7 for clarification on the distinction between these concepts.

Medium: a substance used to convey mass, energy, or information through Equipment or a System. Examples include air, water, refrigerant, and electricity.

PhysicalSpace: an architectural concept that represents a room, a collection of rooms such as a floor, a part of a room, or any physical space that might not even be thought of as a room, such as a patio.

Note: while the word “system” is used colloquially throughout this document (e.g., building system, control system), the System concept has a more formal definition than its colloquial usage.

System: a logical grouping or collection of Equipment, Junction, or other Systems for some defined purpose. Example purposes include all the Equipment and Junctions that provide Domestic Hot Water service in a building, or all fire safety Equipment in a building that must be routinely inspected. A System cannot have a ConnectionPoint. See Clause 5 and Clause 7 for clarification on the distinction between these concepts.

Zone: a collection of DomainSpaces of a specific domain that are grouped together from the perspective of building services or controls\

3.2 Abbreviations and Acronyms Used in this Standard

AHU	Air Handling Unit
ANSI	American National Standards Institute
ASHRAE	American Society of Heating, Refrigerating and Air-Conditioning Engineers
BACnet	Building Automation and Control Networks
CDL	Control Description Language
HVAC	Heating, Ventilation, and Air Conditioning
IFC	Industry Foundation Class
IRI	Internationalized Resource Identifier
LAN	Local Area Network
LL	Line-Line
LN	Line-Neutral
OWL	Web Ontology Language
PM	Particulate Matter
PoE	Power over Ethernet
QUDT	Quantities, Units, Dimensions, and Types
RDF	Resource Description Framework
RDFS	RDF Schema
SHACL	Shapes Constraint Language
SPARQL	SPARQL Protocol and RDF Query Language
USB	Universal Serial Bus
VAV	Variable Air Volume
W3C	World Wide Web Consortium

4 CONCEPTUAL FRAMEWORK FOR SEMANTIC MODELING OF BUILDING SYSTEMS AND DATA

This standard defines modeling constructs for use in creating a machine-readable representation of building systems, the building spaces that they serve, and the measurement and control points used to provide a safe and comfortable environment for the building occupants. The standard can be considered a toolkit of semantic building blocks and rules for using them to create a semantic model of a particular building or campus of buildings. The resulting model provides a way for software applications to determine the relationships between the mechanical equipment in the building (i.e., AHU 1 gets chilled water from CH 3 and provides conditioned air to VAV Boxes 12 through 15 serving rooms on the third floor) and the meaning of measurements that are available (i.e., T16 is a temperature sensor measuring the temperature of the air stream exiting AHU 1).

The model does not directly contain telemetric data about the real-time operation or past operation of the building systems. It does provide information about the meaning or context of that data and defines external references that are used to point to a source of the data values, thus enabling analytics applications to find them. If the data source is a BACnet building automation and control system, the external reference contains the necessary information for analytic software to learn which BACnet device, object, and property corresponds to the desired piece of information. This enables construction of a BACnet message used to read the value.

These capabilities are achieved by applying concepts, standards, and query tools developed and deployed for information and data science applications outside the building domain. A primary commercial driver for developing these standards and tools is the Semantic Web, an extension of the World Wide Web that was created to make the semantic meaning of data accessible from the Internet machine readable.

This standard uses Resource Description Framework (RDF) (W3C) and its extended schema (RDFS) to represent the semantic ideas in the model. RDF is a general method for representing semantic ideas as of a triple. A triple consists of a subject, a predicate, and either a literal or an object. For example:

Jane hasFriend Dave

Jane hasSupervisor Mary

In this example, Jane is the subject of both triples, there are two different predicates, hasFriend and hasSupervisor, and there are two different objects, Dave and Mary. The number of triples is expanded as needed to capture the desired information. The collection of triples represents a directed multi-graph that can be searched or queried to answer questions or to infer information that may not be explicit in the graph. Figure 4-1 is a graph that corresponds to this example.

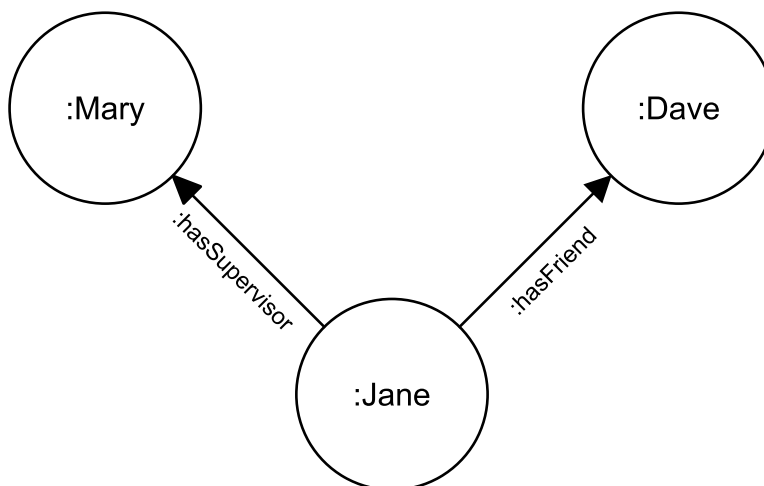

Figure 4-1. Example triple graph.

This standard defines subjects, predicates, and objects relevant to the building space that are used to build a multi-graph representing a specific building or group of buildings. A compelling advantage of this graph-based approach is the ability to combine semantic graphs derived from complementary semantic models that apply to the same building. This makes it possible to take advantage of the combined information from distinct domains. For example, a RealEstateCore model that captures how spaces are assigned to different tenants in a building linked to the spaces represented in a Standard 223 model results in a semantic model containing the combined information. In a similar way, it is possible to link information from a computerized maintenance management system or an asset management system to the semantic graph of a Standard 223 model by adding a triple that binds a piece of equipment to its representation in the other system.

A model constructed from this standard describes the topology of the equipment and spaces in a building but not the geometric details. Linking a Standard 223 model with an RDF representation of a building information model would add that geometric information.

Another advantage of using RDF to model building systems is that a query language standard, SPARQL (W3C SPARQL), exists and tools that implement SPARQL are readily available. A building analytics tool developer needs only to create a library of queries relevant to their application, and use these queries to interrogate any Standard 223 conformant model to find what they need from that building for their application.

Using RDF also provides a way to build conformance constraints into this standard in a way that enables conformance to be algorithmically verified. This is done by using a different W3C standard, Shapes Constraints Language (SHACL) (W3C SHACL). SHACL defines a way to constrain the construction of RDF graphs through the application of custom developed rules called shapes. The normative constraints described in this standard are formalized in SHACL shapes. The description of each concept defined in this standard includes a table that lists related conformance constraints defined by these SHACL shapes. Readily available SHACL reasoners check whether or not a particular model instance conforms to the shapes defined in this standard.

The concepts and relations mentioned below were designed to aid in standard development using RDF and SHACL exclusively and avoiding any dependence on OWL axioms. This approach was chosen to avoid some of the shortcomings of using OWL in industrial settings, such as the open world assumption, the many flavors of OWL and their support, and the sometimes counterintuitive implications of OWL reasoning for non-ontologists. (For example, if an instance satisfies the OWL axioms for a class, then it is inferred to be an instance of that class). The use of SHACL shapes to define constraints and inferencing rules is a more intuitive way to define intended model behavior and to verify conformance to the standard. The two most-used OWL inferences, supporting symmetric and inverse relations, are redefined in this standard using SHACL rules.

4.1 Conformance Constraints and Validation

In this standard, SHACL shapes are used to define conformance constraints. When a SHACL reasoner is applied to a model, discrepancies from the conformance constraints result in a message from the reasoner with one of three levels of severity (sh:severity).

A message with a severity sh:Info means that a model construct is incomplete.

A message with a severity sh:Warning means that a model construct is used in an unexpected way.

A message with a severity sh:Violation means a model construct is invalid and does not comply with the standard.

4.2 Deriving Implicit Information from Inference Rules

SHACL is used in this standard to derive implicit information via a process called inferencing. Inference rules are used to define how new triples are generated. The triples generated from this inference process enhance the ability to make useful queries without the burden of a modeler crafting each one. The goal is to make model development easier without sacrificing the utility application developers need to find what they are looking for. The description of each concept defined in this standard with related inference rules includes a table that lists the relevant SHACL shapes that specify the inferencing.

4.3 Textual Serialization

The normative content of this standard is documented in an RDF model textualized using Turtle (see Clause Annex A). All models conforming to this standard shall be textualized using Turtle.

The Turtle serialization format specifies that IRIs may be written as relative or absolute IRIs or prefixed names. The prefix label is defined by using the “@prefix” directive followed by a colon followed by a partial IRI. The encoding examples used in this document assume the following prefix statements:

```
@prefix s223: <http://data.ashrae.org/standard223#> .  
@prefix bacnet: <https://data.ashrae.org/bacnet/> .  
@prefix qudt: <http://qudt.org/schema/qudt/> .
```

A prefixed name is turned into an IRI by concatenating the IRI associated with the prefix and the local part. The ‘@prefix’ directive associates a prefix label with an IRI, e.g., s223:Equipment expands to <http://data.ashrae.org/standard223#Equipment>. The scope of a prefix label is only within the Turtle file that it appears. It is encouraged to use the prefix statements above when exchanging models.

4.4 Units of Measure

Because this standard includes references to measurements of physical properties, it is necessary to provide a model representation of units of measure as well as what those units are quantifying (e.g. temperature, power, etc.). This standard builds upon the “Quantities, Units, Dimensions, and Types” (QUDT) ontology which is an open-source model expressed in RDF/SHACL. The QUDT model is documented at <https://qudt.org>. The key concepts used here are the classes qudt:Unit and qudt:QuantityKind. The 223 standard is compatible with Version 3.1.1 of QUDT and is expected to be compatible with all newer versions as well.

4.5 Namespace

Because it is anticipated that models conforming to this standard will be combined with other semantic models, it is necessary to define a namespace for the concepts defined by this standard

to avoid any possible ambiguities that might arise from a similar name used in the complementary model. In this standard and all conforming models, the prefix “s223:” shall be used in the name of each concept (class and relation) defined by this standard, e.g., s223:Equipment.

4.6 s223:Concept

All classes and relations defined in the 223 standard are subclasses of Concept.

Related Constraints

Description	Link
A Concept shall be associated with zero or more Property using the relation hasProperty.	Link
Ensure that all instances of an s223 class use only the relations defined for that class. Note that this only applies to QUDT relations.	Link
Ensure that all instances of an s223 class use only the relations defined for that class. Note that this only applies to s223 relations.	Link
Incompatible Medium. Case1: An entity with a pure medium and an associated Property with a different pure medium.	Link
Incompatible Medium. Case2: An entity with a pure medium and an associated Property with constituents.	Link
Incompatible Medium. Case3: An entity with constituents and an associated Property with a pure medium.	Link
Incompatible Medium. Case4: An entity with constituents and an associated Property with constituents.	Link

Related Inference Rules

Description	Link
Add an rdfs:label if it is missing.	Link
Declare the inverse triples for relations that have defined inverse relations	Link
Declare the inverse triples for symmetric relations	Link

4.6.1 s223:Class

This is a modeling construct. All classes defined in the 223 standard are instances of Class.

Related Constraints

Description	Link
A Class shall be associated with at least one label using the relation rdfs:label.	Link
Every SHACL property shape must have an rdfs:comment.	Link
Every SPARQLConstraint must have an rdfs:comment.	Link

Description	Link
Every SPARQLRule must have an rdfs:comment.	Link
Every TripleRule must have an rdfs:comment.	Link
Every class of the 223 standard must also be an instance of sh:NodeShape.	Link
Every class of the 223 standard must be a direct or indirect subclass of s223:Concept.	Link
Every class of the 223 standard must have an rdfs:comment.	Link

4.6.1.1 s223:AbstractClass

This is a modeling construct. Instances of abstract classes cannot be created. All abstract classes in this standard have a more specific subclass.

4.6.2 s223:Relation

A Relation associates the subject and the object in an RDF triple, the *predicate* portion of a (*subject, predicate, object*) triple.

Related Constraints

Description	Link
A Relation shall be associated with at least one label using the relation rdfs:label.	Link

4.6.2.1 s223:RelationWithInverse

An RelationWithInverse is modeling construct used to define symmetric behavior for certain relations in the standard such as connectedTo and connectedFrom.

Related Constraints

Description	Link
A RelationWithInverse shall be associated with exactly one other RelationWithInverse using the relation inverseOf.	Link

4.6.2.1.1 s223:inverseOf

A Relation that associates Relations that are inverses of one another, such as connectedTo and connectedFrom.

4.6.2.2 s223:SymmetricRelation

A modeling construct used to define symmetric behavior for certain relations in the standard such as cnx, connected, and pairedConnectionPoint.

4.7 s223:hasProperty

A Relation that associates a Concept with a Property.

5 EQUIPMENT

In common usage, terms like equipment and system have a variety of ambiguous and possibly conflicting interpretations. A semantic model is an attempt to eliminate such ambiguities and conflicts. Equipment and System have unique definitions and use cases in this ontology. Both concepts can be used to associate multiple pieces of Equipment with a higher-level concept. This association is accomplished using unique predicates. A new instance of Equipment can be associated with other Equipment using the relation `contains` (see Clause 5.2). Note that Equipment is `Connectable` (see Clause 6.5) and the relation `contains` implies physical containment. Alternatively, a System can be associated with one or more instances of Equipment, System or Junction using the relation `hasMember` (see Clause 7). Note that System is not `Connectable` (see Clause 6.5), the relation `hasMember` does not imply physical containment. The decision of whether to model a higher-level concept as an Equipment or a System is a modeler's choice.

5.1 s223:Equipment

Equipment is the modeling construct used to represent a thing designed to accomplish a specific task, or a complex thing that contains component pieces of Equipment that are connected to each other and work together to accomplish a task. Equipment can have `Connections` and `ConnectionPoints` through which one or more kinds of medium (see Clause 10.11.1) might flow. Examples of Equipment defined in this ontology include Pump, Fan, AirHeatExchanger, Luminaire, and Sensor. Equipment can be connected to other `Connectables` such as other Equipment or `DomainSpaces`.

The graphical depiction of Equipment used in this document is a round-cornered rectangle as shown in Figure 5-1.

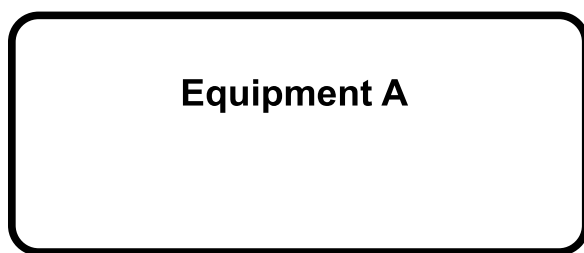

Figure 5-1. Graphical Depiction of Equipment.

Related Constraints

Description	Link
A piece of Equipment shall be associated with zero or more <code>ActuableProperty</code> s using the relation <code>actuatedByProperty</code> .	Link
A piece of Equipment shall be associated with zero or more <code>EnumerationKind-Roles</code> using the relation <code>hasRole</code> .	Link
A piece of Equipment shall be associated with zero or more <code>Functions</code> using the relation <code>executes</code> .	Link
A piece of Equipment shall be associated with zero or more <code>PhysicalSpaces</code> using the relation <code>hasPhysicalLocation</code> .	Link
A piece of Equipment shall be associated with zero or more other pieces of contained Equipment and/or Junctions using the relation <code>contains</code> .	Link
Disallow contained equipment from having external incoming connections.	Link
Disallow contained equipment from having external outgoing connections.	Link
Warning about a subclass of Equipment of type A containing something that is in the same subclass branch.	Link

Related Inference Rules

Description	Link
For equipment contained within another piece of equipment use the <code>mapsTo</code> relation to infer a Medium from the containing equipment.	Link
For equipment containing another piece of equipment, use the <code>mapsTo</code> relation to infer a Medium from the contained equipment.	Link

5.2 Equipment Containment

A piece of equipment can only contain other pieces of equipment. For example, a fan can be contained by an air handling unit. The relation `contains` is used to describe a piece of equipment containing another piece of equipment (see Clause 5.3). The relationship `mapsTo` relates a `ConnectionPoint` of a contained Equipment to the `ConnectionPoint` of a containing Equipment (see Clause 6.2.5). For example, the air inlet to a heating coil contained in a fan coil unit may map to the air inlet of the fan coil unit. Any air connection to the fan coil unit inlet is supplying air to the inlet of the heating coil as well.

Multiple pieces of equipment contained by the same piece of equipment may connect to each other, however, they may not connect to equipment that are not also contained. To indicate how a contained piece of equipment connects to an external piece of equipment, the relationship `mapsTo` is used. `mapsTo` will relate the connection point of a contained equipment to the connection point of the containing equipment, then the connection point of the containing equipment may connect to the external equipment.

It may be desirable for a piece of containing equipment to have a Property that has a value representing something that is associated with a contained piece of equipment. For example, consider a fan coil unit that contains a fan and a coil. The fan may have a Property that represents the speed of the fan. To make this fan speed visible as a Property of the fan coil unit, a fan speed Property would be added to the fan coil unit and its value would be an internal reference (see Clause 11.20) to the speed Property of the contained motor.

5.3 s223:contains

A Relation that associates a piece of Equipment with its component pieces of Equipment, or a PhysicalSpace (see Clause 8.1.1) with its component PhysicalSpaces.

5.4 s223:hasRole

A Relation that associates a role with of a piece of Equipment, a Connection, ConnectionPoint, or System within a building (e.g., a heating coil might be associated with Role-Heating). Possible values are defined in EnumerationKind-Role (see Clause 10.10).

5.5 s223:hasPhysicalLocation

A Relation that associates a piece of Equipment with its physical location (i.e., in a PhysicalSpace). The physical location of a piece of Equipment is not necessarily the same as the location affected by the operation of the Equipment. For example, an air handler may physically be located on the roof, but its effect is to provide conditioned air to a Zone or DomainSpace within the building. By following the path of connections, it can be determined what other equipment or spaces are possibly impacted by the Equipment.

5.6 s223:Sensor

A Sensor observes an ObservableProperty (see Clause 11.3) which may be quantifiable (see Clause 11.7), such as a temperature, flow, or concentration, or enumerable (see Clause 11.8), such as an occupancy state.

If a Sensor observes a QuantifiableObservableProperty relative to an assumed or common reference point, it can be modeled with only an observation location. For example:

```
@prefix : <http://example.com/> .
```

```
:example1 a s223:TemperatureSensor ;  
  s223:hasObservationLocation :location1 ;  
  qudt:hasQuantityKind quantitykind:Temperature .
```

If a Sensor observes a QuantifiableObservableProperty relative to a unique or specified reference point, it can be modeled with an observation location and a reference location, and indicating the difference between two values by setting qudt:isDeltaQuantity to true. For example:

```
@prefix : <http://example.com/> .
```

```
:example2 a s223:TemperatureSensor ;
```

```
s223:hasObservationLocation :location1 ;
s223:hasReferenceLocation :location2 ;
qudt:hasQuantityKind quantitykind:Temperature ;
qudt:isDeltaQuantity true .
```

Related Constraints

Description	Link
A Sensor can be associated with a maximum of one Connectable, Connection, or ConnectionPoint using the relation hasReferenceLocation.	Link
A Sensor shall be associated with exactly 1 of Connectable, Connection, or ConnectionPoint using the relation hasObservationLocation.	Link
A Sensor shall be associated with exactly 1 of QuantifiableObservableProperty or EnumeratedObservableProperty using the relation observes.	Link
A Sensor shall be associated with exactly one ObservableProperty using the relation observes.	Link
A Sensor shall be associated with exactly one location using the relation hasObservationLocation.	Link
A Sensor shall be associated with zero or more QuantifiablePropertyys using the relation hasMeasurementResolution.	Link
If a Sensor measures a differential property, it shall be associated with a reference location using the relation hasReferenceLocation.	Link
If the hasReferenceLocation relation exists, the observed Property shall have qudt:isDeltaQuantity true.	Link
If the observed Property has qudt:isDeltaQuantity true, the Sensor shall have a hasReferenceLocation relation.	Link

Related Inference Rules

Description	Link
Infer the hasObservationLocation relation for a Sensor from the Property that it is observing, only if that Property is associated with a single entity.	Link

5.6.1 s223:ConcentrationSensor

A Sensor that observes a QuantifiableObservableProperty that represents a concentration of a miscible constituent in a medium, in contrast to a ParticulateSensor that observes a QuantifiableObservableProperty that represents an amount of a particulate in a medium (see Clause 5.6.7). The 223 standard does not constrain the Unit or QuantityKind reported by a ConcentrationSensor, but possible QuantityKinds include Concentration (moles per volume), Density (mass per volume), MoleFraction, and VolumeFraction.

5.6.2 s223:ElectricCurrentSensor

A Sensor that observes a QuantifiableObservableProperty that represents a measure of electric current.

Related Constraints

Description	Link
An ElectricCurrentSensor shall always observe a QuantifiableObservableProperty that has a QuantityKind of ElectricCurrent.	Link

5.6.3 s223:FlowSensor

A Sensor that observes a QuantifiableObservableProperty that represents a measure of flow of fluid, typically with a QuantityKind of VolumeFlowRate.

5.6.4 s223:HumiditySensor

A Sensor that observes a QuantifiableObservableProperty that represents a measure of relative or absolute humidity.

Related Constraints

Description	Link
A HumiditySensor shall always observe a QuantifiableObservableProperty that has a QuantityKind of either RelativeHumidity or AbsoluteHumidity.	Link

5.6.5 s223:LightSensor

A Sensor that observes a QuantifiableObservableProperty that represents an attribute of light, as specified by the QuantityKind of the Property being observed, as described below.

5.6.5.1 s223:IlluminanceSensor

A LightSensor that observes a QuantifiableObservableProperty that represents an illuminance, defined as the areal density of the luminous flux incident at a point on a surface.

Related Constraints

Description	Link
An IlluminanceSensor shall observe a QuantifiableObservableProperty that has a QuantityKind of Illuminance.	Link

5.6.5.2 s223:CorrelatedColorTemperatureSensor

A LightSensor that observes a QuantifiableObservableProperty that represents a correlated color temperature (CCT) of a light source, defined as the absolute temperature of a blackbody whose chromaticity most nearly resembles that of the light source.

Related Constraints

Description	Link
A <code>CorrelatedColorTemperatureSensor</code> shall always observe a <code>QuantifiableObservableProperty</code> that has a <code>QuantityKind</code> of <code>CorrelatedColorTemperature</code> .	Link

5.6.5.3 s223:DuvSensor

A `LightSensor` that observes a `QuantifiableObservableProperty` that represents a Duv of a light source, defined as the distance between the chromaticity of the light source and a blackbody radiator of equal correlated color temperature (CCT).

Related Constraints

Description	Link
A <code>DuvSensor</code> shall always observe a <code>QuantifiableObservableProperty</code> that has a <code>QuantityKind</code> of <code>Duv</code> .	Link

5.6.6 s223:OccupancySensor

A `Sensor` that observes an `ObservableProperty` that represents an attribute of occupancy in a space.

5.6.6.1 s223:OccupantMotionSensor

An `OccupancySensor` that observes a `ObservableProperty` that represents motion within a sensing region.

Related Constraints

Description	Link
An <code>OccupantMotionSensor</code> shall always observe an <code>EnumeratedObservableProperty</code> that has an <code>EnumerationKind</code> of <code>Occupancy-Motion</code> .	Link

5.6.6.2 s223:OccupantPresenceSensor

An `OccupancySensor` that observes a `ObservableProperty` that represents presence within a sensing region.

Related Constraints

Description	Link
An <code>OccupantPresenceSensor</code> shall always observe an <code>EnumeratedObservableProperty</code> that has an <code>EnumerationKind</code> of <code>Occupancy-Presence</code> .	Link

5.6.6.3 s223:OccupantCountSensor

An OccupancySensor that observes a QuantifiableObservableProperty that represents a population, usually of humans, within a sensing region.

Related Constraints

Description	Link
An OccupantCountSensor shall always observe a QuantifiableObservableProperty that has a QuantityKind of Population and a Unit of NUM.	Link

5.6.7 s223:ParticulateSensor

A Sensor that observes a QuantifiableObservableProperty that represents an amount of a particulate in a medium, in contrast to a ConcentrationSensor that observes a QuantifiableObservableProperty that represents a concentration of a miscible constituent in a medium (see Clause 5.6.1).

The 223 standard does not constrain the Unit or QuantityKind reported by a ParticulateSensor, but possible QuantityKinds include Density (mass per volume), ParticleNumberDensity (count per volume), and DimensionlessRatio (with units such as PPM or PPB). Some particulate sensors may claim to report a raw count of particles, for which a QuantityKind of Count could be used, but the required context for such a measurement should be provided in the sensor's documentation to specify if it in fact measures a count per volume (e.g., ParticleNumberDensity), time (e.g., CountRate or ParticleCurrent), or some other combination. Explicitly declaring the QuantityKind of a sensor's output is preferable to relying on implicit assumptions.

Related Constraints

Description	Link
A ParticulateSensor shall be associated with zero or more Substance-Particulates using the relation ofSubstance.	Link

5.6.8 s223:PressureSensor

A Sensor that observes a QuantifiableObservableProperty that represents a measure of pressure.

Related Constraints

Description	Link
A PressureSensor shall always observe a QuantifiableObservableProperty that has a QuantityKind of Pressure.	Link

5.6.8.1 s223:GaugePressureSensor

A PressureSensor that observes a QuantifiableObservableProperty that represents a measure of pressure relative to atmospheric pressure. Such sensors are commonly used to monitor compressed gas cylinders, for example, where a gauge reading of zero signifies that the measured pressure is equal to the atmospheric pressure, not a vacuum.

Related Constraints

Description	Link
A GaugePressureSensor shall always observe a QuantifiableObservableProperty that has a QuantityKind of GaugePressure.	Link
A GaugePressureSensor shall always observe a QuantifiableObservableProperty that has a value of true for qudt:isDeltaQuantity.	Link

5.6.9 s223:TemperatureSensor

A Sensor that observes a QuantifiableObservableProperty that represents a measure of temperature.

Related Constraints

Description	Link
A TemperatureSensor shall always observe a QuantifiableObservableProperty that has a QuantityKind of Temperature.	Link

5.6.10 s223:VoltageSensor

A Sensor that observes a QuantifiableObservableProperty that represents a measure of voltage.

Related Constraints

Description	Link
A VoltageSensor shall always observe a QuantifiableObservableProperty that has a QuantityKind of Voltage.	Link

5.6.11 s223:hasMeasurementResolution

A Relation that associates a Sensor with the QuantifiableProperty whose value indicates the smallest recognizable change in engineering units that the Sensor is able to measure.

5.6.12 s223:observes

A Relation that associates a Sensor with one ObservableProperty (see Clause 11.3) which is used by the sensor to generate a measurement value (e.g., a temperature) or a simple observation of a stimulus causing a reaction (e.g., a current binary switch that closes a dry contact when a fan is powered on).

5.6.13 s223:hasObservationLocation

A Relation that associates a Sensor with the topological location where it is observing a Property (see Clause 5.6.12). The observation location shall be a Connectable (see Clause 6.1), Connection (see Clause 6.3), or ConnectionPoint (see Clause 6.2).

5.6.14 s223:hasReferenceLocation

A Relation that associates a differential sensor with the topological location of the baseline (reference) Property (see Clause 5.6.12).

5.7 s223:Actuator

A piece of Equipment that receives control signals and electrically, pneumatically, or hydraulically makes changes in the physical world, such as the position of a valve or damper.

Related Constraints

Description	Link
An Actuator shall be associated with at least one ActuatableProperty using the relation actuatedByProperty.	Link
An Actuator shall be associated with zero or more pieces of Equipment using the relation actuates.	Link

5.7.1 s223:actuates

A Relation that associates an Actuator with the Equipment that it actuates.

5.7.2 s223:actuatedByProperty

A Relation that associates a piece of Equipment with the ActuatableProperty that it responds to. If the Equipment is an Actuator (a subclass of Equipment), actuatedByProperty is a required relation. An Actuator may also identify another piece of Equipment being actuated. (see Clause 5.7.1).

5.8 s223:Controller

A piece of equipment for regulation of a system or component in normal operation, which executes one or more Functions.

Related Constraints

Description	Link
A Controller shall be associated with zero or more Functions using the relation executes.	Link

5.8.1 s223:Function

A Function is used to model transfer and/or transformation of information (i.e., Property). It has relations to input Properties and output Properties. The actual algorithms that perform the transformations are described in CDL and are out of scope of the 223 standard.

Related Constraints

Description	Link
A Function shall be associated with at least one Property using either the relation hasInput or hasOutput.	Link
A Function shall be associated with zero or more input Propertyts using the relation hasInput.	Link
A Function shall be associated with zero or more output Propertyts using the relation hasOutput.	Link

5.8.1.1 s223:hasInput

A Relation that associates a Function (see Clause 5.8.1) with a Property (see Clause 11.1) that is used as input to the Function.

5.8.1.2 s223:hasOutput

A Relation that associates a Function (see Clause 5.8.1) with a Property (see Clause 11.1) that is calculated by the Function.

5.8.2 s223:executes

A Relation that associates a Controller (see Clause 5.8) with the Functions (see Clause 5.8.1) that it executes.

6 CONNECTION

This clause is the top level of the hierarchical structure of the portion of the model that represents the characteristics and features of connections that provide a means for a medium such as air, water, or electricity, to flow from one ConnectionPoint to another. Examples of connections are ducts, pipes, and conductors.

6.1 s223:Connectable

Connectable is an abstract class representing a thing such as Equipment (see Clause 5.1), DomainSpace (see Clause 8.2.1), or Junction (see Clause 6.4) that can be connected to other Connectables via ConnectionPoints and Connections.

Related Constraints

Description	Link
A Connectable shall be associated with zero or more ConnectionPoints that may not be connected using the relation hasOptionalConnectionPoint. The “dangling connection point” should not generate a validation error.	Link
A Connectable shall be associated with zero or more ConnectionPoints using the relation cnx.	Link
A Connectable shall be associated with zero or more ConnectionPoints using the relation hasConnectionPoint.	Link
A Connectable shall be associated with zero or more Connections using the relation connectedThrough.	Link
A Connectable shall be associated with zero or more other Connectables using the relation connectedFrom.	Link
A Connectable shall be associated with zero or more other Connectables using the relation connectedTo.	Link
A Connectable shall be associated with zero or more other Connectables using the relation connected.	Link
If a Connectable has connected or connectedTo (i.e., high-level connection specification), it must also have the supporting cnx relations (low-level connection specification).	Link

Related Inference Rules

Description	Link
Infer the cnx relation using isConnectionPointOf.	Link
Infer the cnx relationship using hasConnectionPoint.	Link
Infer the connectedFrom relations using connectsThrough and connectsFrom.	Link
Infer the connectedThrough relation using hasConnectionPoint and connectsThrough	Link
Infer the connectedTo relation using connectsThrough and connectsTo.	Link
Infer the connected relation for BiDirectional connections	Link
Infer the connected relation for BiDirectional connections	Link
Infer the connected relation using connectedFrom	Link
Infer the connected relation using connectedTo	Link
Infer the hasConnectionPoint relation using cnx	Link

6.2 s223:ConnectionPoint

A ConnectionPoint is an abstract modeling construct used to represent the fact that one connectable thing can be connected to another connectable thing using a Connection. It is the

abstract representation of the flange, wire terminal, or other physical feature where a connection is made. Equipment, DomainSpaces and Junctions can have one or more ConnectionPoints (see Clause 6.1).

A ConnectionPoint is constrained to relate to a specific medium such as air, water, or electricity which determines what other things can be connected to it. For example, constraining a ConnectionPoint to be for air means it cannot be used for an electrical connection.

A ConnectionPoint belongs to exactly one connectable thing (see Clause 6.1).

ConnectionPoints are represented graphically in this standard by a triangle with the point indicating a direction of flow, or a diamond in the case of a bidirectional flow as shown in Figure 6-1.

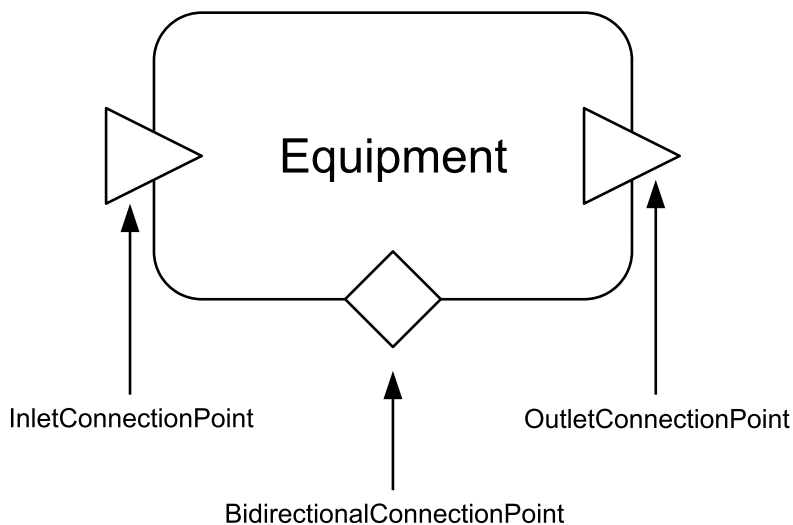

Figure 6-1. Graphical Representation of a ConnectionPoint
 Related Constraints

Description	Link
A ConnectionPoint must not have both a mapsTo and a connectsThrough relation.	Link
A ConnectionPoint shall be associated with at most one Connectable using the relation cnx.	Link
A ConnectionPoint shall be associated with at most one Connection using the relation cnx.	Link
A ConnectionPoint shall be associated with at most one EnumerationKind-ElectricalPhaseIdentifier using the relation hasElectricalPhase.	Link

Description	Link
A ConnectionPoint shall be associated with at most one other ConnectionPoint using the inverse of the relation mapsTo.	Link
A ConnectionPoint shall be associated with at most one other ConnectionPoint using the inverse of the relation pairedConnectionPoint.	Link
A ConnectionPoint shall be associated with at most one other ConnectionPoint using the relation mapsTo.	Link
A ConnectionPoint shall be associated with at most one other ConnectionPoint using the relation pairedConnectionPoint.	Link
A ConnectionPoint shall be associated with exactly one Connectable using the relation isConnectionPointOf.	Link
A ConnectionPoint shall be associated with exactly one Substance-Medium using the relation hasMedium.	Link
A ConnectionPoint shall be associated with zero or more EnumerationKind-Roles using the relation hasRole.	Link
A ConnectionPoint should be associated with at most one Connection using the relation connectsThrough.	Link
Ensure that the Medium identified by a ConnectionPoint via the hasMedium relation is compatible with the Medium identified by the entity identified by the mapsTo relation.	Link
If a ConnectionPoint mapsTo another ConnectionPoint, the respective Equipment should have a contains relation.	Link
If a ConnectionPoint lacks a connectsThrough and mapsTo relation, and is not associated with a Junction or Equipment that is contained by an Equipment, then suggest that the ConnectionPoint probably needs an association with a Connection.	Link
If a ConnectionPoint lacks a connectsThrough and mapsTo relation, but is associated with a Junction or Equipment that is contained by an Equipment, then suggest that the ConnectionPoint might need a mapsTo relation to a ConnectionPoint of the containing Equipment.	Link
Subclasses of ConnectionPoint are Disjoint. An instance of a subclass of ConnectionPoint cannot be an instance of multiple such subclasses.	Link

Related Inference Rules

Description	Link
Infer the hasElectricalPhase value from any connected Conductor.	Link

6.2.1 s223:BidirectionalConnectionPoint

A BidirectionalConnectionPoint is a ConnectionPoint for which a Substance-Medium is expected to flow either into or out of the associated Connectable.

Related Constraints

Description	Link
A BidirectionalConnectionPoint shall be associated with at most one ConnectionPoint using the relation pairedConnectionPoint.	Link
A BidirectionalConnectionPoint shall be associated with at most one other BidirectionalConnectionPoint using the relation mapsTo.	Link

6.2.2 s223:InletConnectionPoint

An InletConnectionPoint is a ConnectionPoint for which a Substance-Medium is expected to flow into the associated Connectable.

Related Constraints

Description	Link
An InletConnectionPoint shall be associated with at most one OutletConnectionPoint or BidirectionalConnectionPoint using the relation pairedConnectionPoint.	Link
An InletConnectionPoint shall be associated with at most one other InletConnectionPoint using the relation mapsTo.	Link
Ensure an InletConnectionPoint has a mapsTo relation to its containing Equipment if it has an external Connection	Link

6.2.3 s223:OutletConnectionPoint

An OutletConnectionPoint is a ConnectionPoint for which a Substance-Medium is expected to flow out of the associated Connectable.

Related Constraints

Description	Link
An OutletConnectionPoint shall be associated with at most one InletConnectionPoint or BidirectionalConnectionPoint using the relation pairedConnectionPoint.	Link
An OutletConnectionPoint shall be associated with at most one other OutletConnectionPoint using the relation mapsTo.	Link
Ensure an OutletConnectionPoint has a mapsTo relation to its containing Equipment if it has an external Connection.	Link

6.2.4 s223:pairedConnectionPoint

A Relation that associates two ConnectionPoints where an InletConnectionPoint shares the same Substance-Medium with an OutletConnectionPoint.

6.2.5 s223:mapsTo

A Relation that associates a `ConnectionPoint` of a `Connectable` with a corresponding `ConnectionPoint` of the one containing it. The associated `ConnectionPoints` shall have a compatible medium (see Clause 10.11.1).

6.2.6 s223:hasMedium

The relation `hasMedium` is used to indicate what medium is flowing through the connection (e.g., air, water, electricity). The possible values are defined in `Substance-Medium` (see Clause 10.11.1).

6.3 s223:Connection

A `Connection` is the modeling construct used to represent the thing (e.g., pipe, duct, conductor, or free space) that is used to convey some `Medium` (e.g., water, air, electricity, light, Wi-Fi) between two connectable things. All connections have two or more connection points bound to either `Equipment` (see Clause 5.1), `DomainSpace` (see Clause 8.2.1), or `Junction` (see Clause 6.4). See Figure 6-2. If the direction of flow is constrained, that constraint is indicated by using one or more `InletConnectionPoints` (see Clause 6.2.2) to represent the inflow points and `OutletConnectionPoints` (see Clause 6.2.3) to represent the outflow points.

A `Connection` may contain branches or intersections. These may be modeled using `Junctions` if it is necessary to identify a specific intersection. (see Clause 6.4).

The constraint to maintain compatible mediums among a `Connection` and all of its associated `ConnectionPoints` gives rise to multiple validation test cases, where the specified medium might be a pure medium, or a mixture with constituents. See Clause 10.11.1 for more details.

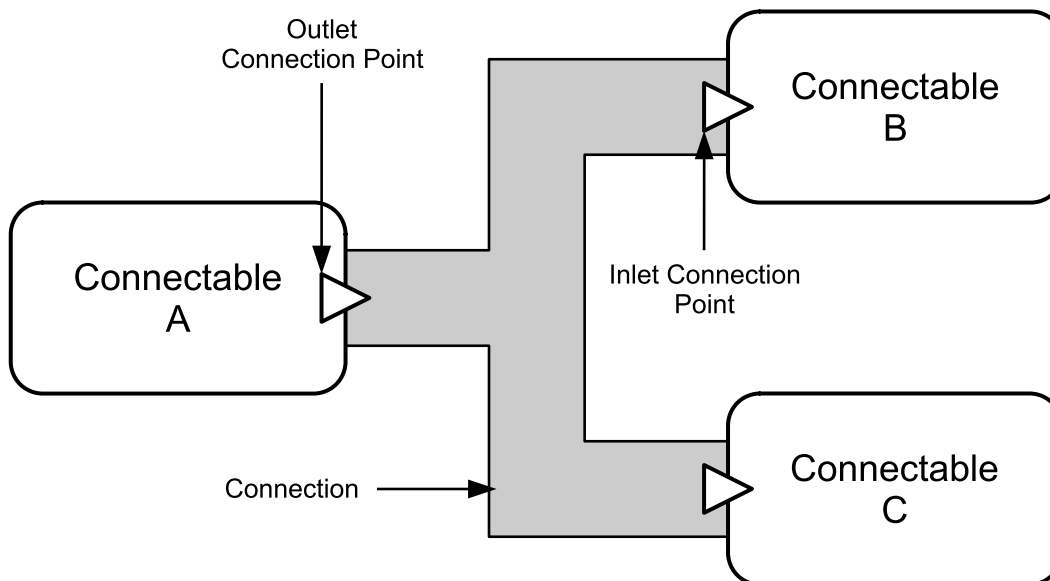

Figure 6-2. Graphical Depiction of Connection.

Related Constraints

Description	Link
A Connection must only have a cnx relation with a ConnectionPoint	Link
A Connection shall be associated with at least two ConnectionPoints using the relation connectsAt.	Link
A Connection shall be associated with at most one EnumerationKind-ThermodynamicPhase using the relation hasThermodynamicPhase.	Link
A Connection shall be associated with exactly one Substance-Medium using the relation hasMedium.	Link
A Connection shall be associated with zero or more Connectables using the relation connectsFrom.	Link
A Connection shall be associated with zero or more Connectables using the relation connectsTo.	Link
A Connection shall be associated with zero or more ConnectionPoints using the relation cnx.	Link
A Connection shall be associated with zero or more EnumerationKind-Roles using the relation hasRole.	Link
Incompatible Medium. Case 1: A Connection with a pure medium and an associated ConnectionPoint with a pure medium.	Link

Description	Link
Incompatible Medium. Case 2: A Connection with constituents and an associated ConnectionPoint with a pure medium.	Link
Incompatible Medium. Case 3: Connection with a pure medium and an associated ConnectionPoint with constituents.	Link
Incompatible Medium. Case 4: A Connection with constituents and an associated ConnectionPoint with constituents.	Link
Incompatible Medium. Case 5: Two ConnectionPoints with pure mediums.	Link
Incompatible Medium. Case 6: Two ConnectionPoints, one with a medium with constituents and one with a pure medium.	Link
Incompatible Medium. Case 7: Two ConnectionPoints with mediums with constituents.	Link
You need either an InletConnectionPoint and an OutletConnectionPoint, or at least one BidirectionalConnectionPoint and another ConnectionPoint of any type.	Link

Related Inference Rules

Description	Link
Infer cnx relation using the relation connectsAt.	Link
Infer cnx relation using the relation connectsThrough.	Link
Infer the connectsAt relation using the relation cnx.	Link
Infer the connectsFrom relation using the relation connectsAt.	Link
Infer the connectsTo relation using the relation connectsAt.	Link

6.3.1 s223:EM

A type of Connection that represents air, a vacuum, outer space, or a similar environment used to convey electromagnetic energy i.e., Constituent-EM, without the use of solid materials such as fiber optic cables or other such Waveguides.

Related Constraints

Description	Link
An EM shall be associated with exactly one Constituent-EM using the relation hasMedium.	Link

6.3.2 s223:Pipe

A Connection that is used primarily to transport liquids and gases such as water, sewage, natural gas, and compressed air.

6.3.3 s223:Duct

A Connection that is used to transport air such as supply, return, and exhaust in HVAC (Heating, Ventilation, and Air Conditioning) systems.

6.3.4 s223:Conductor

A Connection that represents one or more wires used to convey Constituent-Electricity. Each instance of Conductor applies to no more than one electrical circuit.

Related Constraints

Description	Link
A Conductor shall be associated with at most one EnumerationKind-ElectricalPhaseIdentifier using the relation hasElectricalPhase.	Link
A Conductor shall be associated with exactly one Constituent-Electricity using the relation hasMedium.	Link
Ensure the electrical phase is the same as all connected ConnectionPoints	Link

Related Inference Rules

Description	Link
Infer the hasElectricalPhase value from any connected ConnectionPoints.	Link

6.3.4.1 s223:EthernetCable

A type of Conductor that consists of 1, 2 or 4 pairs of twisted wire and is used for Signal-WiredEthernet communication. Subclasses of EthernetCable represent common types used in buildings.

EthernetCable Subclasses

Subclass
EthernetCable-Cat1
EthernetCable-Cat2
EthernetCable-Cat3
EthernetCable-Cat4
EthernetCable-Cat5
EthernetCable-Cat5e
EthernetCable-Cat6
EthernetCable-Cat6a
EthernetCable-Cat7
EthernetCable-Cat7a
EthernetCable-Cat8

Related Constraints

Description	Link
An EthernetCable shall be associated with exactly one Signal-WiredEthernet using the relation hasMedium.	Link

6.3.4.2 s223:USBCable

A type of Conductor that consists of 1 to 5 pairs of twisted wire and is used for Signal-USB communication.

Related Constraints

Description	Link
A USBCable shall be associated with exactly one Signal-USB using the relation hasMedium.	Link

6.3.5 s223:Waveguide

A type of Connection that represents structures, such as fiber optic or coaxial cables, used to convey electromagnetic energy i.e., Constituent-EM in a specific direction. Without the physical constraint of a waveguide, waves would expand into three-dimensional space and their intensities would decrease according to the inverse square law.

Related Constraints

Description	Link
A Waveguide shall be associated with exactly one Constituent-EM using the relation hasMedium.	Link

6.3.5.1 s223:CoaxialCable

A type of Waveguide that consists of a central conductor, surrounded by an insulator, a metallic shield, and an outer jacket, all sharing the same geometric axis - which allows it to efficiently transmit high-frequency signals over long distances with minimal interference - and is used for Wideband-DOCSIS and Wideband-CATV communication.

Related Constraints

Description	Link
A CoaxialCable shall be associated with exactly one Wideband-DOCSIS or Wideband-CATV using the relation hasMedium.	Link

6.3.5.2 s223:FiberOpticCable

A type of Waveguide that consists of thin, flexible strands of glass or plastic fibers that transmit data as pulses of light and is used for Signal-FiberEthernet or Wideband-CATV communication. Subclasses of FiberOpticCable represent common types used in buildings.

FiberOpticCable Subclasses

Subclass
FiberOpticCable-OM1
FiberOpticCable-OM2
FiberOpticCable-OM3
FiberOpticCable-OM4
FiberOpticCable-OM5
FiberOpticCable-OS1
FiberOpticCable-OS2

Related Constraints

Description	Link
A FiberOpticCable shall be associated with exactly one Signal-FiberEthernet or Wideband-CATV using the relation hasMedium.	Link

6.4 s223:Junction

A Junction is a modeling construct used when a branching point within a Connection (see Clause 6.3) is of significance, such as specifying the observation location of a Sensor, or when a modeler wants to expose a branch point within a containing piece of Equipment. When a Junction is used, what might have been modeled as a single, branched Connection is separated into three or more separate connections, all tied together with the Junction and its associated connection points.

Junction is a subclass of Connectable, which gives it the ability to have connection points, but unlike Equipment (and like Connection) it is not allowed to change the Substance-Medium that passes through it. This is why Junction is a sibling class to Equipment and not a subclass. This constraint to maintain compatible mediums among a Junction and all of its associated ConnectionPoints gives rise to multiple validation test cases, where the specified medium might be a pure medium, or a mixture with constituents (see Clause 10.11.1).

Related Constraints

Description	Link
A Junction shall be associated with at least two connection points using the relation hasConnectionPoint.	Link
A Junction shall be associated with exactly one Substance-Medium using the relation hasMedium.	Link
A Junction shall have at least two ConnectionPoints including (a) at least one inlet and one outlet, or (b) at least one bidirectional connection point.	Link
Incompatible Medium. Case 2: A Junction with constituents and an associated ConnectionPoint with a pure medium.	Link

Description	Link
Incompatible Medium. Case 3: Junction with a pure medium and an associated ConnectionPoint with constituents	Link
Incompatible Medium. Case 6: Two ConnectionPoints, one with a medium with constituents and one a pure medium.	Link
Incompatible Medium. Case 7: Two ConnectionPoints with mediums with constituents.	Link
Incompatible Medium. Case1: A Junction with a pure medium and an associated ConnectionPoint with a pure medium.	Link
Incompatible Medium. Case4: Junction with constituents and an associated ConnectionPoint with constituents.	Link
Incompatible Medium. Case5: Two ConnectionPoints with pure mediums.	Link
This Junction is not used to model significant details of a branching point in a connection, and may not be required.	Link

6.5 Relations Describing Connectedness

The collection of relations defined for Connectable, ConnectionPoint, and Connection is intended to facilitate model queries that answer questions about how equipment is connected and to what it is connected. These relations are shown in Figure 6-3.

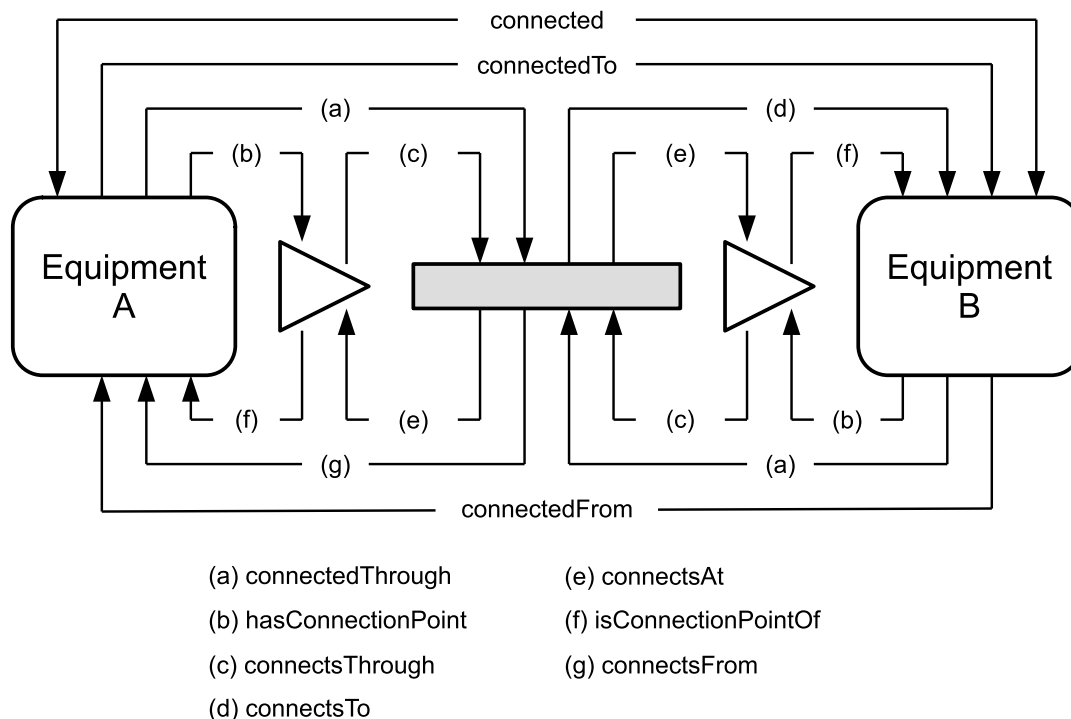

Figure 6-3. Connection Relations.

It is not necessary for a model developer to create each of these relations individually. A model can be created using a simpler construct shown in Figure 6-4 using the `cnx` relation. Inference rules can then be applied to generate the complete set shown in Figure 6-3. The intent is to simplify model development without losing the connectedness relationships that facilitate model queries.

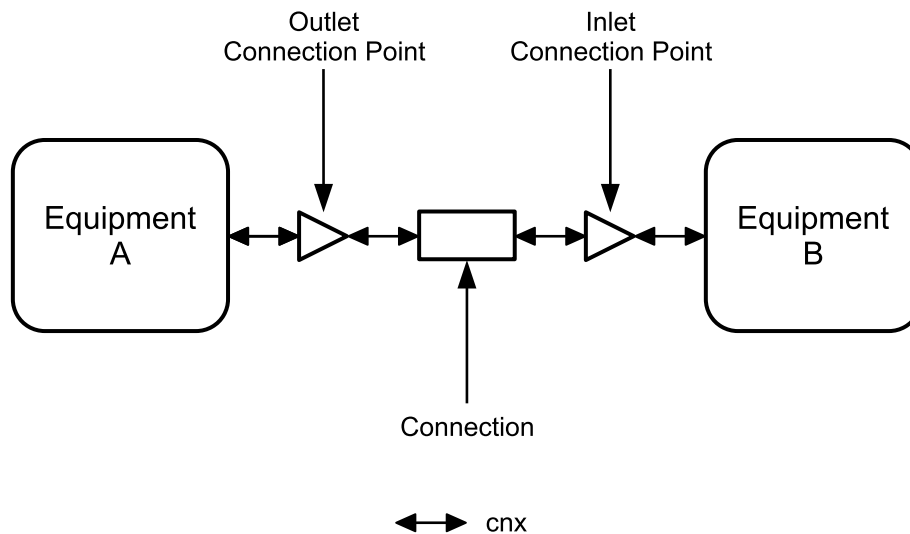

Figure 6-4. CNX Relations.

6.5.1 s223:connected

The relation `connected` indicates that two connectable things are connected without regard to the direction of flow.

6.5.2 s223:connectedTo

The relation `connectedTo` indicates that connectable things are connected with a specific direction of flow. A is `connectedTo` B, means a direction of flow from A to B. The inverse direction is indicated by `connectedFrom` (see Clause 6.5.3).

6.5.3 s223:connectedFrom

The relation `connectedFrom` indicates that connectable things are connected with a specific direction of flow. B is `connectedFrom` A, means that the direction of flow is from A to B. The inverse direction is indicated by `connectedTo` (see Clause 6.5.2).

6.5.4 s223:connectedThrough

A Relation that associates a Connectable thing with a Connection, without regard to the direction of flow. It is used to discover what connection links two connectable things.

6.5.5 s223:connectsTo

A Relation that associates a Connection with a Connectable thing, with an implied direction of flow. A `connectsTo` B indicates a flow from A to B.

6.5.6 s223:connectsFrom

A Relation that associates a Connectable thing with a Connection, with an implied direction of flow. B connectsFrom A indicates a flow from A to B.

6.5.7 s223:connectsThrough

A Relation that associates a ConnectionPoint with a Connection, without regard to the direction of flow.

6.5.8 s223:connectsAt

A Relation that associates a Connection with a specific ConnectionPoint.

6.5.9 s223:hasConnectionPoint

One of two Relations that associates Connectable thing with a ConnectionPoint. It is the inverse of the relation isConnectionPointOf (see Clause 6.5.10).

6.5.10 s223:isConnectionPointOf

One of two Relations that associates a ConnectionPoint with a Connectable thing. It is the inverse of the relation hasConnectionPoint (see Clause 6.5.9).

6.5.11 s223:cnx

A Relation that associates adjacent entities in a connection path, comprised of Equipment-ConnectionPoint-Connection-ConnectionPoint-Equipment sequences.

6.6 s223:hasMedium

The relation hasMedium is used to indicate what medium is flowing through the connection (e.g., air, water, electricity). The possible values are defined in Substance-Medium (see Clause 10.11.1).

7 SYSTEM

In common usage, terms like equipment and system have a variety of ambiguous and possibly conflicting interpretations. A semantic model is an attempt to eliminate such ambiguities and conflicts. Equipment and System have unique definitions and use cases in this ontology. Both concepts can be used to associate multiple pieces of Equipment with a higher-level concept. This association is accomplished using unique predicates. A new instance of Equipment can be associated with other Equipment using the relation contains (see Clause 5.2). Note that Equipment is Connectable (see Clause 6.5) and the relation contains implies physical containment. Alternatively, a System can be associated with one or more instances of Equipment, System, or Junction using the relation hasMember (see Clause 7). Note that System is not Connectable (see Clause 6.5), the relation hasMember does not imply physical containment. The decision of whether to model a higher-level concept as an Equipment or a System is a modeler's choice.

7.1 s223:System

A logical grouping of one or more pieces of Equipment, Junctions, or other Systems for some functional purpose.

Related Constraints

Description	Link
A System shall be associated with at least one piece of Equipment, Junction, or System using the relation hasMember.	Link
A System shall be associated with zero or more ConnectionPoints that are the “boundary” of the equipment using the relation hasBoundaryConnectionPoint. The hasBoundaryConnectionPoint relation is used to reference those connection points of its equipment that must be connected, but in the context of validating the model with the system by itself, the “dangling connection point” should not generate a validation error.	Link
A System shall be associated with zero or more ConnectionPoints that are the “boundary” of the equipment using the relation hasBoundaryConnectionPoint. The hasBoundaryConnectionPoint relation is used to reference those connection points of its equipment that must be connected, but in the context of validating the model with the system by itself, the “dangling connection point” should not generate a validation error.	Link
A System shall be associated with zero or more EnumerationKind-Roles using the relation hasRole.	Link
Ensure that the boundary ConnectionPoints of a System belong to only members of that System	Link

Related Inference Rules

Description	Link
Infer the hasBoundaryConnectionPoint relation using hasOptionalConnectionPoint.	Link

7.2 s223:hasMember

A Relation that associates a System with its component Equipment and/or Systems.

7.3 s223:hasBoundaryConnectionPoint

The hasBoundaryConnectionPoint relation means the ConnectionPoint represents the boundary of a System (see Clause 7.1) defined by the modeler, such as a model fragment provided by the vendor of a collection of equipment intended for integration with another model. The presence of this relation is used to indicate that such a “dangling connection point” should not generate a validation error in a non-integrated context but should generate an error in an integrated context.

7.4 s223:hasOptionalConnectionPoint

The hasOptionalConnectionPoint relation means that the ConnectionPoint is optional and is not required to be connected. The presence of this relation is used to indicate that such a “dangling connection point” should not generate a validation error in an integrated or non-integrated context.

8 SPACE

There are two types of spaces: PhysicalSpace and DomainSpace. PhysicalSpaces represent the building from the architectural and occupant perspective. A PhysicalSpace may represent a room (e.g., an office or conference room), a part of a room (e.g., a foyer), a collection of rooms (e.g., a floor or the entire building), or any other physical region in a building (e.g., a patio or a roof), or a whole campus.

A DomainSpace is a subclass of Connectable (see Clause 6.1) that represents some portion of a PhysicalSpace that is affected by a building service associated with a particular domain (e.g., HVAC, lighting, see Clause 10.5). DomainSpaces can be viewed as the endpoints of building services.

DomainSpaces can represent an entire PhysicalSpace or a portion of a PhysicalSpace, and thus PhysicalSpaces enclose DomainSpaces. An instance of a PhysicalSpace may enclose DomainSpaces from different domains, and may also enclose multiple DomainSpaces of the same domain. For example, a PhysicalSpace may represent an office that encloses a single HVAC DomainSpace and multiple lighting DomainSpaces. This would indicate a single HVAC service is provided to the office, along with multiple lighting services (e.g., one that provides lighting to the area of the office that receives daylight, and another that provides lighting to the area of the office that does not receive daylight). Multiple DomainSpaces of the same domain may overlap. For example, a DomainSpace affected by lighting devices that provide general lighting service to a room may overlap with the DomainSpace affected by the lighting devices that provide emergency lighting service to a room.

8.1 Physical Space

8.1.1 s223:PhysicalSpace

An architectural concept representing a room, a part of a room, a collection of rooms, or any other physical region in a building. PhysicalSpaces may be grouped to define larger PhysicalSpaces using the relation contains (see Clause 5.3).

Related Constraints

Description	Link
A PhysicalSpace shall be associated with zero or more contained PhysicalSpaces using the relation contains.	Link
A PhysicalSpace shall be associated with zero or more enclosed DomainSpaces using the relation encloses.	Link

8.1.2 s223:encloses

A Relation that associates a PhysicalSpace with one or more DomainSpaces.

8.1.3 s223:OutdoorPhysicalSpace

A PhysicalSpace that is outside of the building where, for example, outdoor ambient properties might be measured, within a suitably defined DomainSpace.

8.2 Domain Space

8.2.1 s223:DomainSpace

A portion of a PhysicalSpace that is affected by a building service associated with a domain. DomainSpaces may represent an entire PhysicalSpace or any portion of a PhysicalSpace (see Clause 8.1.1). Multiple DomainSpaces of the same domain may overlap, and DomainSpaces of different domains may also overlap, but DomainSpaces can not overlap multiple PhysicalSpaces. DomainSpaces may be grouped into Zones using the relation hasDomainSpace (see Clause 9.2).

Related Constraints

Description	Link
A DomainSpace must be enclosed by a PhysicalSpace.	Link
A DomainSpace shall be associated with exactly one EnumerationKind-Domain using the relation hasDomain.	Link

Related Inference Rules

Description	Link
Infer a hasDomain relation by checking any enclosing Zone to determine the domain.	Link

8.2.2 s223:hasDomain

A Relation that associates a Zone or DomainSpace with an EnumerationKind-Domain (e.g., Domain-HVAC, Domain-Lighting).

9 ZONE

A Zone is a logical grouping of one or more DomainSpaces and/or Zones of a specific domain for some building service or control-related purpose. Multiple Zones of the same domain may overlap. For example, a Zone that defines DomainSpaces that are subject to an occupancy-control strategy may overlap with a Zone that defines DomainSpaces that are subject to a supervisory scheduled-control strategy.

9.1 s223:Zone

A logical grouping of one or more DomainSpaces or other Zones for some building service or control-related purpose. Zones can have properties that are inputs or outputs to a Function (see Clause 5.8.1), which can be executed by Controllers (see Clause 5.8) or other Equipment.

Related Constraints

Description	Link
A Zone must not contain itself, directly or indirectly.	Link
A Zone shall be associated with at least one DomainSpace using the relation hasDomainSpace or be associated with at least one Zone using the relation hasZone.	Link
A Zone shall be associated with at least one DomainSpace using the relation hasDomainSpace or be associated with at least one Zone using the relation hasZone.	Link
A Zone shall be associated with exactly one EnumerationKind-Domain using the relation hasDomain.	Link
The associated domain of a Zone and the Domain of the DomainSpaces it contains must be the same.	Link

Related Inference Rules

Description	Link
If an instance of Zone matches the constraints defined by g36:Zone, it will be declared as an instance of that class.	Link
If an instance of Zone matches the constraints defined by g36:ZoneGroup, it will be declared as an instance of that class.	Link
Infer a hasDomain relation by checking any enclosed DomainSpaces to determine the domain.	Link
Infer a hasDomain relation by checking any enclosed Zone to determine the domain.	Link

9.2 s223:hasDomainSpace

A Relation that associates a Zone with its component DomainSpaces.

9.3 s223:hasZone

A Relation that associates a Zone with component Zones.

10 ENUMERATIONS

Enumerations are sets of values that are closed (they cannot take on values outside of what is explicitly listed in the definition) and named (each value has a unique name). The values within an enumeration share a “kind,” which communicates how the enumerations are intended to be used.

The standard uses enumerations to convey groups of useful values for describing attributes of things e.g., Properties, Equipment.

10.1 s223:EnumerationKind

This is the encapsulating class for all EnumerationKinds. EnumerationKinds define the (closed) set of permissible values for a given purpose. For example, EnumerationKind-DayOfWeek enumerates the days of the week and allows no other values.

EnumerationKinds are arranged in a class hierarchy tree, with the root class named EnumerationKind. Each subclass is named starting with its immediate superclass, followed by a hyphen and a name that is unique among the sibling classes. Each class is also an instance of itself. This unusual modeling pattern was used to achieve:

- The ability to set an EnumerationKind value that is more general, or not yet fully specified at the time of modeling, such as Electricity-AC without having to state exactly what voltage or frequency it is.
- The ability to use the `sh:class SHACL` predicate at any level in the EnumerationKind hierarchy to constrain a value in the s223 specification, even if it is a more general one such as Electricity-AC in the above example.

Certain validation constraints exist in the standard that evaluate compatibility of EnumerationKinds. Two values are deemed compatible if they are the same, if one is a direct ancestor (or descendant) of the other, or if they are mixtures sharing at least one constituent.

10.2 s223:EnumerationKind-Aspect

Aspect enumerations provide context to the meaning of a Property that would otherwise not be apparent.

10.2.1 Equipment Information

These aspects are used on properties that provide static information about something e.g., a System, or Equipment. These aspects are typically used on properties of type Property. The property value is typically stored as a string.

Aspect Equipment Information Enumerations

Enumeration	Description
Aspect-CatalogNumber	The property value is a number or other identifier of a product in a manufacturer's catalog.
Aspect-Manufacturer	The property value is a name or other identifier of the product's manufacturer.
Aspect-Model	The property value is a model identifier of the product.
Aspect-SerialNumber	The property value is the serial number assigned by the manufacturer to the system or equipment.

10.2.2 Equipment Operation

These aspects are used on properties that provide dynamic information about something e.g., a System, or Equipment. These aspects are typically used on properties of type `EnumerableProperty` and subtypes thereof.

Aspect Equipment Operation Enumerations

Enumeration	Description
Aspect-Alarm	The property value indicates whether an alarm condition is active or provides details about an active alarm.
Aspect-Fault	The property value is a fault indicator or code that signals a malfunction or issue with the system or equipment.
Aspect-OperatingMode	The property value is the current intended mode of operation, such as 'Automatic', 'On', or 'Off'.
Aspect-OperatingStatus	The property value is the current operational status of the system or equipment, such as 'Running,' 'Stopped,' or 'Maintenance Mode.'

10.2.3 Operational Limits

These aspects are used on properties that define the range of another Property. These aspects are used on properties of type `QuantifiableObservableProperty`.

Aspect Operational Limits Enumerations

Enumeration	Description
Aspect-Maximum	The property value is a highest specified or observed value. (Examples: upper limit of the specified operating voltage range; maximum measured temperature.)
Aspect-Minimum	The property value is a lowest specified or observed value. (Examples: lower limit of the specified operating voltage range; minimum measured temperature.)
Aspect-Nominal	The property value is a value that is expected or desired under normal operating conditions, but may not reflect the actual value at all times. (Example: nominal voltage.)
Aspect-Rated	The property value indicates a limit for continuous safe operation set by the manufacturer, but may not reflect the actual value at all times. (Example: rated voltage.)

10.2.4 Control Parameters

These aspects are used on properties that define the limits for control and alarm algorithms. These aspects are used on properties of type `QuantifiableActuableProperty`.

Aspect Control Parameters Enumerations

Enumeration	Description
Aspect-Deadband	The property value is a range around a setpoint where no control action is taken to avoid unnecessary corrections.
Aspect-HighLimit	The property value is an upper threshold used in a control or alarm detection algorithm.
Aspect-LowLimit	The property value is a lower threshold used in a control or alarm detection algorithm.
Aspect-Setpoint	The property value is a target value for a control algorithm.
Aspect-Threshold	The property value is a threshold used in a control algorithm.

10.2.5 Delta Quantities

These aspects are used on properties to modify the quantity kind. These aspects are used on properties of type `QuantifiableProperty` and subtypes thereof.

Aspect Delta Quantities Enumerations

Enumeration	Description
Aspect-Delta	The property value is a differential value (e.g., pressure difference) instead of an absolute value.

10.3 s223:EnumerationKind-Binary

This class and its enumerated subclasses represent common binary values.

EnumerationKind-Binary Enumerations

Enumeration
Binary-Logical
Binary-OnOff
Binary-Position

10.3.1 s223:Binary-Logical

This class and its enumerated subclasses represent the possible values of a logical Property i.e., True or False.

Binary-Logical Enumerations

Enumeration
Logical-False
Logical-True

10.3.2 s223:Binary-OnOff

This class and its enumerated subclasses represent basic operational states i.e., On and Off.

Binary-OnOff Enumerations

Enumeration
OnOff-Off
OnOff-On

10.3.3 s223:Binary-Position

This class and its enumerated subclasses represent basic positional states i.e., Closed and Open.

Binary-Position Enumerations

Enumeration
Position-Closed
Position-Open

10.4 s223:EnumerationKind-DayOfWeek

This class and its enumerated subclasses represent the days of the week, according to the Gregorian calendar i.e., Monday, Tuesday, Wednesday, Thursday, Friday, Saturday, and Sunday. The Weekend and Weekday EnumerationKinds define subsets of this EnumerationKind for Mon-Fri and Sat, Sun, respectively.

EnumerationKind-DayOfWeek Enumerations

Enumeration
DayOfWeek-Weekday
DayOfWeek-Weekend

10.4.1 s223:DayOfWeek-Weekday

This class and its enumerated subclasses represent weekdays according to the Gregorian calendar, i.e., Monday, Tuesday, Wednesday, Thursday, and Friday.

DayOfWeek-Weekday Enumerations

Enumeration
Weekday-Friday
Weekday-Monday

Enumeration
Weekday-Thursday
Weekday-Tuesday
Weekday-Wednesday

10.4.2 s223:DayOfWeek-Weekend

This class and its enumerated subclasses represent weekend days according to the Gregorian calendar, i.e., Saturday and Sunday.

DayOfWeek-Weekend Enumerations

Enumeration
Weekend-Saturday
Weekend-Sunday

10.5 s223:EnumerationKind-Domain

This class and its enumerated subclasses represent building systems and services e.g., HVAC, Lighting, and Plumbing.

EnumerationKind-Domain Enumerations

Enumeration
Domain-ConveyanceSystems
Domain-Electrical
Domain-FireProtection
Domain-HVAC
Domain-Lighting
Domain-Networking
Domain-Occupancy
Domain-PhysicalSecurity
Domain-Plumbing
Domain-Refrigeration

10.6 s223:EnumerationKind-ElectricalPhaseIdentifier

This class and its enumerated subclasses represent all possible electrical phases for AC electricity service.

EnumerationKind-ElectricalPhaseIdentifier Enumerations

Enumeration
ElectricalPhaseIdentifier-A
ElectricalPhaseIdentifier-AB

Enumeration
ElectricalPhaseIdentifier-ABC
ElectricalPhaseIdentifier-B
ElectricalPhaseIdentifier-BC
ElectricalPhaseIdentifier-C
ElectricalPhaseIdentifier-CA

10.6.1 s223:hasElectricalPhase

A Relation that associates a Conductor or ConnectionPoint with at most one EnumerationKind-ElectricalPhaseIdentifier.

10.7 s223:EnumerationKind-Numerical

Numerical enumeration kinds are used to support the definitions of the Constituent-Electricity. The enumerations instances in these classes have names that are recognizable by humans but are just a string for a computer application. To avoid the need to parse strings, each of these EnumerationKinds have relations with the EnumerationKinds that represent electrical phase, voltage, and frequency. The purpose of these properties is to enable a machine to query them and obtain the same information that a person would associate with the string.

Related Constraints

Description	Link
An EnumerationKind-Numerical shall be associated with at most one decimal value using the relation hasValue.	Link
An EnumerationKind-Numerical shall be associated with exactly one QuantityKind using the relation qudt:hasQuantityKind.	Link
An EnumerationKind-Numerical shall be associated with exactly one Unit using the relation qudt:hasUnit.	Link

10.7.1 s223:Numerical-Frequency

This class and its enumerated subclasses represent common frequencies for AC electricity service.

Numerical-Frequency Enumerations

Enumeration
Frequency-50Hz
Frequency-60Hz

Related Constraints

Description	Link
A Numerical-Frequency shall have a QuantityKind of Frequency.	Link
A Numerical-Frequency shall have a Unit of HZ (hertz).	Link

10.7.2 s223:Numerical-NumberOfElectricalPhases

This class and its enumerated subclasses represent all possible service phases for AC electricity service, i.e., single-phase or three-phase. The `hasNumberOfElectricalPhases` relation points to one of the values of this enumeration.

Numerical-NumberOfElectricalPhases Enumerations

Enumeration
NumberOfElectricalPhases-SinglePhase
NumberOfElectricalPhases-ThreePhase

10.7.3 s223:Numerical-Voltage

This class and its enumerated subclasses represent common voltages for electricity service.

Numerical-Voltage Enumerations

Enumeration
Voltage-0V
Voltage-2.5V
Voltage-3V
Voltage-5V
Voltage-6V
Voltage-12V
Voltage-24V
Voltage-48V
Voltage-110V
Voltage-120V
Voltage-127V
Voltage-139V
Voltage-190V
Voltage-208V
Voltage-219V
Voltage-220V
Voltage-230V
Voltage-240V
Voltage-277V

Enumeration
Voltage-347V
Voltage-380V
Voltage-400V
Voltage-415V
Voltage-480V
Voltage-600V
Voltage-1730V
Voltage-1900V
Voltage-2400V
Voltage-3000V
Voltage-3300V
Voltage-3460V
Voltage-3810V
Voltage-4160V
Voltage-5770V
Voltage-6000V
Voltage-6600V
Voltage-10000V
Voltage-PoE (see ?)

Related Constraints

Description	Link
A Numerical-Voltage shall have a QuantityKind of Voltage.	Link
A Numerical-Voltage shall have a Unit of V (volt).	Link

10.8 s223:EnumerationKind-Occupancy

This class and its enumerated subclasses represent the occupancy status of a space within a building, i.e., the state of being occupied by a human being. The Occupancy-Motion and Occupancy-Presence subclasses are associated with specific characteristics of occupancy and associated means of detection, while the Occupancy-Occupied subclass is generic, in that it is not associated with a specific characteristic or occupancy or associated means of detection.

10.8.1 s223:Occupancy-Motion

This class and its enumerated subclasses represent the detection of human motion in a space.

Occupancy-Motion Enumerations

Enumeration
Motion-False
Motion-True

10.8.2 s223:Occupancy-Presence

This class and its enumerated subclasses represent the detection of human presence in a space.

Occupancy-Presence Enumerations

Enumeration
Presence-False
Presence-True

10.8.3 s223:Occupancy-Occupied

This class and its enumerated subclasses represent the generic detection of human occupancy in a space.

Occupancy-Occupied Enumerations

Enumeration
Occupied-False
Occupied-True

10.9 s223:EnumerationKind-ThermodynamicPhase

This class and its enumerated subclasses represent thermodynamic phases, also referred to as states of matter.

EnumerationKind-ThermodynamicPhase Enumerations

Enumeration
ThermodynamicPhase-Gas (see Clause 10.9.1)
ThermodynamicPhase-Liquid (see Clause 10.9.2)
ThermodynamicPhase-Solid
ThermodynamicPhase-Vapor

10.9.1 s223:ThermodynamicPhase-Gas

This class and its enumerated subclasses represent gas in various thermodynamic states.

ThermodynamicPhase-Gas Enumerations

Enumeration
Gas-Superheated

10.9.2 s223:ThermodynamicPhase-Liquid

This class and its enumerated subclasses represent liquid in various thermodynamic states.

ThermodynamicPhase-Liquid Enumerations

Enumeration
Liquid-Subcooled

10.9.3 s223:hasThermodynamicPhase

A Relation that associates a Medium with its thermodynamic phases.

10.10 s223:EnumerationKind-Role

This class and its enumerated subclasses represent roles played by entities, such as cooling, generator, relief, and return. These enumeration kinds are intended to indicate the capability of an entity to play a given role, rather than the role being actively played at any given point in time. For example, a reversible piece of equipment might play a role of Role-Cooling at one time, and Role-Heating at another time. Such an entity would be modeled using the hasRole relation with both role values. The active role at a particular time can be modeled as a Property with an ExternalReference to telemetry data.

EnumerationKind-Role Enumerations

Enumeration
Role-Condenser
Role-Cooling
Role-Dehumidifying
Role-Discharge
Role-Economizer
Role-Evaporator
Role-Exhaust
Role-Expansion
Role-Generator
Role-Heating
Role-HeatRecovery
Role-HeatTransfer
Role-Load
Role-OutdoorAirIntake
Role-Primary
Role-Recirculating
Role-Relief
Role-Return
Role-Secondary

Enumeration
Role-Supply
Role-Ventilating

10.11 s223:EnumerationKind-Substance

This class and its enumerated subclasses represent things that are produced, conveyed, sensed, controlled, or consumed. Its enumerated subclasses differentiate between mediums, particulates, and soot.

EnumerationKind-Substance Enumerations

Enumeration
Substance-Medium (see Clause 10.11.1)
Substance-Particulate (see Clause 10.11.2)
Substance-Soot (see Clause 10.11.3)

Related Constraints

Description	Link
If a substance has a constituent, that constituent may not itself have constituents.	Link

10.11.1 s223:Substance-Medium

This class and its enumerated subclasses represent substances that facilitate the conveyance of matter, energy, or information. It is used to qualify `Connections` and `ConnectionPoints` with the relation `hasMedium` (see Clause 6.6).

`Substance-Medium` is also the root of the medium hierarchy that is used to ensure compatibility of different medium designations. For example, `Fluid-Water` and `Water-ChilledWater` are alternative but compatible ways of identifying what is flowing in a pipe, using different degrees of specificity. `Water-ChilledWater` and `Water-HotWater` are not compatible. Compatibility is determined by testing if one medium is a subclass of the other. This gets a bit more complicated in the case of mixtures, where at least one of the constituents of a mixture must be compatible with at least one of the constituents of the other medium.

Testing for medium compatibility is done in the context of entities that have a `hasMedium` relation, such as

- `Connection` and its associated `ConnectionPoints`. See Clause 6.3.
- `Junction` and its associated `ConnectionPoints`. See Clause 6.4.
- `Filter` and its associated `ConnectionPoints`. See Clause 12.35.
- Any `Concept` that has a `hasMedium` relation, compared with an associated `Property` with an `ofMedium` relation. See Clause 4.6.

These tests are listed in the constraint tables for the respective classes listed above, identified as Case 1, Case 2, etc.

Substance-Medium Enumerations

Enumeration
Medium-Constituent (see Clause 10.11.1.1)
Medium-MechanicalLinkage
Medium-Mix (see Clause 10.11.1.2)
Medium-ThermalContact

10.11.1.1 s223:Medium-Constituent

This class and its enumerated subclasses represent substances that may be combined to form a Medium-Mix. Constituents are distinguished from Medium-Mix and its subclasses in that constituents cannot use the composedOf relation to reference a concentration of other constituents.

Medium-Constituent Enumerations

Enumeration
Constituent-Ar
Constituent-CH4
Constituent-CO
Constituent-CO2
Constituent-Electricity (see Clause 10.11.1.1.1)
Constituent-EM (see Clause 10.11.1.1.2)
Constituent-Glycol
Constituent-H2O
Constituent-H2S
Constituent-N2
Constituent-NH3
Constituent-NOX (see Clause 10.11.1.1.3)
Constituent-O2
Constituent-O3
Constituent-Oil
Constituent-Radon
Constituent-Refrigerant (see Clause 10.11.1.1.4)
Constituent-SO2
Constituent-VolatileOrganicCompounds

Related Constraints

Description	Link
A Medium-Constituent shall not be associated with any substances using the relation composedOf.	Link

10.11.1.1.1 s223:Constituent-Electricity

This class and its enumerated subclasses represent common forms of electrical energy, including AC, DC, and electrical communication signals.

Constituent-Electricity Enumerations

Enumeration
Electricity-AC (see Clause 10.11.1.1.1.1)
Electricity-DC (see Clause 10.11.1.1.1.2)
Electricity-Earth
Electricity-Neutral
Electricity-Signal (see Clause 10.11.1.1.1.3)

10.11.1.1.1.1 s223:Electricity-AC

This class and its enumerated subclasses represent common AC electricity services.

Electricity-AC Enumerations

Enumeration
AC-24VLN-1Ph-50Hz
AC-24VLN-1Ph-60Hz
AC-110VLN-1Ph-50Hz
AC-120VLN-1Ph-60Hz
AC-127VLN-1Ph-50Hz
AC-139VLN-1Ph-50Hz
AC-190VLL-1Ph-50Hz
AC-190VLL-3Ph-50Hz
AC-190VLL-110VLN-1Ph-50Hz
AC-190VLL-110VLN-3Ph-50Hz
AC-208VLL-1Ph-60Hz
AC-208VLL-3Ph-60Hz
AC-208VLL-120VLN-1Ph-60Hz
AC-208VLL-120VLN-3Ph-60Hz
AC-208VLN-1Ph-60Hz
AC-219VLN-1Ph-60Hz
AC-220VLL-1Ph-50Hz

Enumeration
AC-220VLL-3Ph-50Hz
AC-220VLL-127VLN-1Ph-50Hz
AC-220VLL-127VLN-3Ph-50Hz
AC-230VLN-1Ph-50Hz
AC-240VLL-1Ph-50Hz
AC-240VLL-1Ph-60Hz
AC-240VLL-3Ph-50Hz
AC-240VLL-3Ph-60Hz
AC-240VLL-120VLN-1Ph-60Hz
AC-240VLL-139VLN-1Ph-50Hz
AC-240VLL-139VLN-3Ph-50Hz
AC-240VLL-208VLN-120VLN-1Ph-60Hz
AC-240VLL-208VLN-120VLN-3Ph-60Hz
AC-240VLN-1Ph-50Hz
AC-277VLN-1Ph-60Hz
AC-347VLN-1Ph-60Hz
AC-380VLL-1Ph-60Hz
AC-380VLL-3Ph-60Hz
AC-380VLL-219VLN-1Ph-60Hz
AC-380VLL-219VLN-3Ph-60Hz
AC-400VLL-1Ph-50Hz
AC-400VLL-3Ph-50Hz
AC-400VLL-230VLN-1Ph-50Hz
AC-400VLL-230VLN-3Ph-50Hz
AC-415VLL-1Ph-50Hz
AC-415VLL-3Ph-50Hz
AC-415VLL-240VLN-1Ph-50Hz
AC-415VLL-240VLN-3Ph-50Hz
AC-480VLL-1Ph-60Hz
AC-480VLL-3Ph-60Hz
AC-480VLL-277VLN-1Ph-60Hz
AC-480VLL-277VLN-3Ph-60Hz
AC-600VLL-1Ph-60Hz
AC-600VLL-3Ph-60Hz
AC-600VLL-347VLN-1Ph-60Hz
AC-600VLL-347VLN-3Ph-60Hz
AC-1730VLN-1Ph-60Hz
AC-1900VLN-1Ph-60Hz

Enumeration
AC-2400VLN-1Ph-60Hz
AC-3000VLL-1Ph-60Hz
AC-3000VLL-3Ph-60Hz
AC-3000VLL-1730VLN-1Ph-60Hz
AC-3000VLL-1730VLN-3Ph-60Hz
AC-3300VLL-1Ph-60Hz
AC-3300VLL-3Ph-60Hz
AC-3300VLL-1900VLN-1Ph-60Hz
AC-3300VLL-1900VLN-3Ph-60Hz
AC-3460VLN-1Ph-60Hz
AC-3810VLN-1Ph-60Hz
AC-4160VLL-1Ph-60Hz
AC-4160VLL-3Ph-60Hz
AC-4160VLL-2400VLN-1Ph-60Hz
AC-4160VLL-2400VLN-3Ph-60Hz
AC-5770VLN-1Ph-60Hz
AC-6000VLL-1Ph-60Hz
AC-6000VLL-3Ph-60Hz
AC-6000VLL-3460VLN-1Ph-60Hz
AC-6000VLL-3460VLN-3Ph-60Hz
AC-6600VLL-1Ph-60Hz
AC-6600VLL-3Ph-60Hz
AC-6600VLL-3810VLN-1Ph-60Hz
AC-6600VLL-3810VLN-3Ph-60Hz
AC-10000VLL-1Ph-60Hz
AC-10000VLL-3Ph-60Hz
AC-10000VLL-5770VLN-1Ph-60Hz
AC-10000VLL-5770VLN-3Ph-60Hz

Related Constraints

Description	Link
An Electricity-AC shall be associated with at least one Numerical-Frequency using the relation hasFrequency.	Link
An Electricity-AC shall be associated with at least one Numerical-NumberOfElectricalPhases using the relation hasNumberOfElectricalPhases.	Link
An Electricity-AC shall be associated with zero or more Numerical-Voltages using the relation hasACLineLineVoltage.	Link
An Electricity-AC shall be associated with zero or more Numerical-Voltages using the relation hasACLineNeutralVoltage.	Link

10.11.1.1.1.1.1 1-Phase 3-Wire (LLN) 120V/240V

A 1-phase (also referred to as split-phase), 3-wire, 120V/240V transformer, the 3 electricity services it is capable of providing, and their associated mediums.

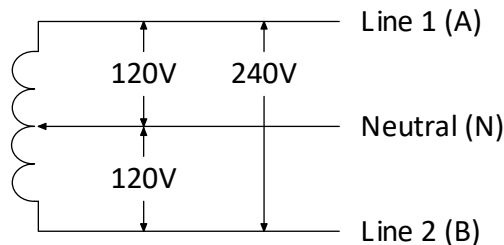

Figure 10-1. 1-Phase 3-Wire (LLN) 120V/240V

Medium	# wires	L-L	L-N	Countries	Phase Possibilities
AC-240VLL-120VLN-1Ph-60Hz	3	240	120	US, Canada	ABN
AC-240VLL-1Ph-60Hz	2	240	-	US, Canada	AB
AC-120VLN-1Ph-60Hz	2	-	120	US, Canada	AN, BN

10.11.1.1.1.1.2 3-Phase 3-Wire (LLL) 480V Delta

A 3-phase, 3-wire, 480V Delta transformer, the 2 AC electricity services it is capable of providing, and their associated mediums.

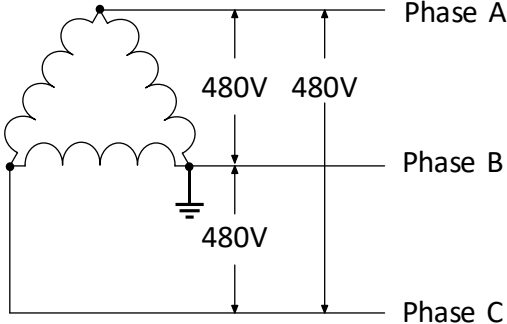

Figure 10-2. 3-Phase 3-Wire (LLL) 480V Delta

Medium	# wires	L-L	L-N	Countries	Phase Possibilities
AC-480VLL-3Ph-60Hz	3	480	-	US	ABC
AC-480VLL-1Ph-60Hz	2	480	-	US	AB, BC, AC

10.11.1.1.1.3 3-Phase 4-Wire (LLLN) 347V/600V Wye

A 3-phase, 4-Wire, 347V/600V Wye transformer, the 3 AC electricity services it is capable of providing, and their associated mediums.

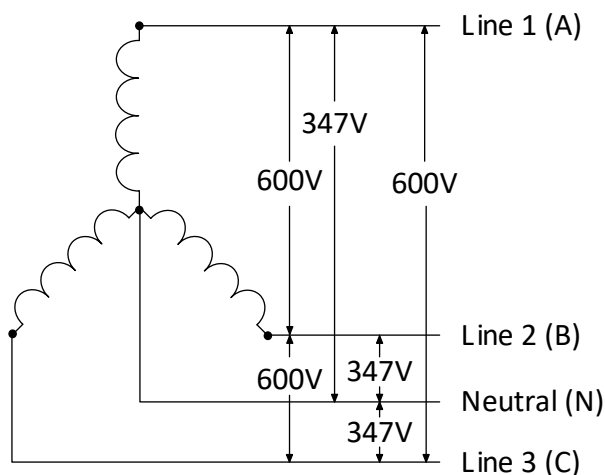

Figure 10-3. 3-Phase 4-Wire (LLLN) 347V/600V Wye

Medium	# wires	L-L	L-N	Countries	Phase Possibilities
AC-600VLL-347VLN-3Ph-60Hz	3	600	347	US, Canada	ABCN
AC-600VLL-1Ph-60Hz	2	600	-	US, Canada	AB, BC, AC
AC-347VLN-1Ph-60Hz	2	-	347	US, Canada	AN, BN, CN

10.11.1.1.1.4 3-Phase 4-Wire (LLLN) 120V/208V/240V High Leg Delta

A 3-Phase, 4-Wire, 120V/208V/240V High Leg Delta transformer, the 6 AC electricity services it is capable of providing, and their associated mediums.

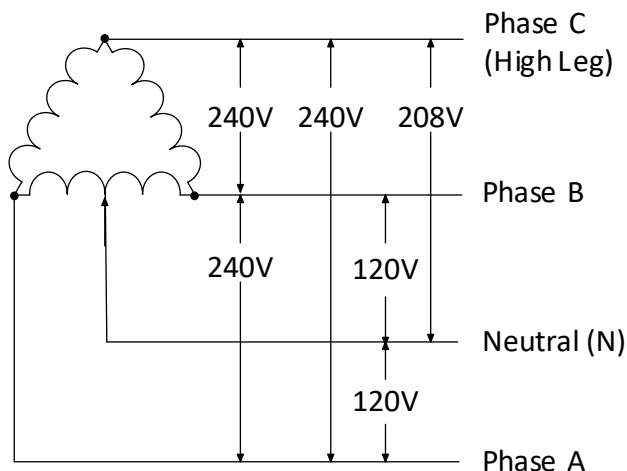

Figure 10-4. 3-Phase 4-Wire (LLLN) 120V/208V/240V High Leg Delta

Medium	# wires	L-L	L-N	Countries	Phase Possibilities
AC-240VLL-208VLN-120VLN-3Ph-60Hz	4	240	208, 120	US	ABCN
AC-240VLL-208VLN-120VLN-1Ph-60Hz	4	240	208, 120	US	ACN, BCN
AC-240VLL-120VLN-1Ph-60Hz	3	240	120	US	ABN
AC-240VLL-3Ph-60Hz	3	240	-	US	ABC
AC-240VLL-1Ph-60Hz	2	240	-	US	AB, BC, AC
AC-120VLN-1Ph-60Hz	2	-	120	US	AN, BN

10.11.1.1.1.5 3-Phase 4-Wire (LLLN) 120V/208V Wye

A 3-phase, 4-wire 120V/208V Wye transformer, the 5 AC electricity services it is capable of providing, and their associated mediums.

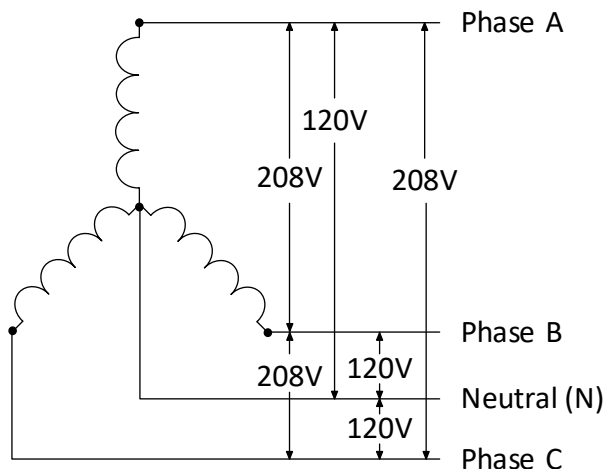

Figure 10-5. 3-Phase 4-Wire (LLLN) 120V/208V Wye

Medium	# wires	L-L	L-N	Countries	Phase Possibilities
AC-208VLL-120VLN-3Ph-60Hz	4	208	120	US, Canada	ABCN
AC-208VLL-120VLN-1Ph-60Hz	4	208	120	US, Canada	ABN, BCN, ACN
AC-208VLL-3Ph-60Hz	3	208	-	US, Canada	ABC
AC-208VLL-1Ph-60Hz	2	208	-	US, Canada	AB, BC, AC
AC-120VLN-1Ph-60Hz	2	-	120	US, Canada	AN, BN, CN

10.11.1.1.1.6 3-Phase 4-Wire (LLLN) 230V/400V Wye

A 3-phase, 4-wire 230V/400V Wye transformer, the 5 AC electricity services it is capable of providing, and their associated mediums.

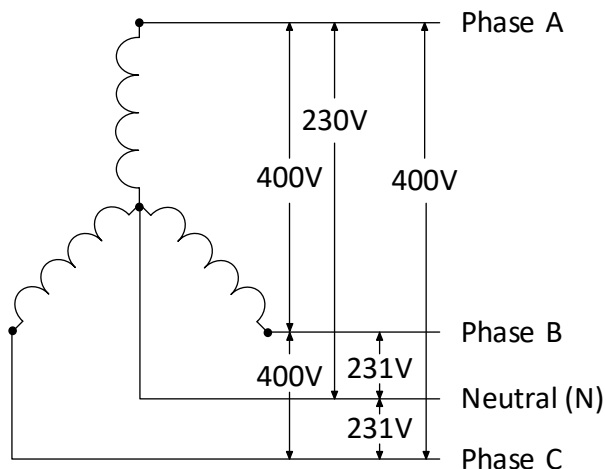

Figure 10-6. 3-Phase 4-Wire (LLLN) 230V/400V Wye

Medium	# wires	L-L	L-N	Countries	Phase Possibilities
AC-400VLL-230VLN-3Ph-50Hz	4	400	230	EU	ABCN
AC-400VLL-230VLN-1Ph-50Hz	4	400	230	EU	ABN, BCN, ACN
AC-400VLL-3Ph-50Hz	3	400	-	EU	ABC
AC-400VLL-1Ph-50Hz	2	400	-	EU	AB, BC, AC
AC-230VLN-1Ph-50Hz	3	-	230	EU	AN, BN, CN

10.11.1.1.1.7 3-Phase 4-Wire (LLLN) 240V/415V Wye

A 3-phase, 4-wire, 240V/415V Wye transformer, the 5 AC electricity services it is capable of providing, and their associated mediums.

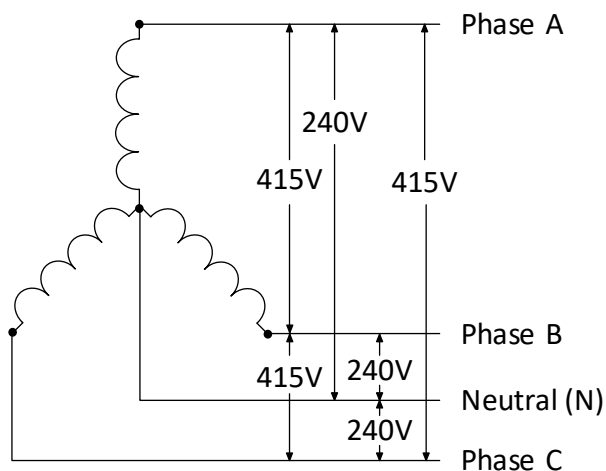

Figure 10-7. 3-Phase 4-Wire (LLLN) 240V/415V Wye

Medium	# wires	L-L	L-N	Countries	Phase Possibilities
AC-415VLL-240VLN-3Ph-50Hz	4	415	240	Australia	ABCN
AC-415VLL-240VLN-1Ph-50Hz	3	415	240	Australia	ABN, BCN, ACN
AC-415VLL-3Ph-50Hz	3	415	-	Australia	ABC
AC-415VLL-1Ph-50Hz	2	415	-	Australia	AB, BC, AC
AC-240VLN-1Ph-50Hz	2	-	240	Australia	AN, BN, CN

10.11.1.1.1.1.8 s223:hasACLLineLineVoltage

A Relation that associates a Constituent-Electricity with an electrical voltage between two live lines.

10.11.1.1.1.1.9 s223:hasACLLineNeutralVoltage

A Relation that associates an Electricity-AC medium with an electrical voltage between a live line and a neutral line.

10.11.1.1.1.1.10 s223:hasFrequency

A Relation that associates an AC electricity Substance-Medium with its electrical frequency.

10.11.1.1.1.1.11 s223:hasNumberOfElectricalPhases

A Relation that associates an AC electricity Substance-Medium with its number of electrical phases.

10.11.1.1.1.2 s223:Electricity-DC

This class and its enumerated subclasses represent common DC electricity services.

Electricity-DC Enumerations

Enumeration
DC-5V
DC-6V
DC-12V
DC-24V
DC-48V
DC-380V
DC-PoE

Related Constraints

Description	Link
An Electricity-DC shall be associated with at least one Numerical-Voltage using the relation hasDCDifferentialVoltage.	Link
An Electricity-DC shall be associated with zero or more Numerical-Voltages using the relation hasDCNegativeVoltage.	Link
An Electricity-DC shall be associated with zero or more Numerical-Voltages using the relation hasDCPositiveVoltage.	Link
An Electricity-DC shall be associated with zero or more Voltage-0Vs using the relation hasDCZeroVoltage.	Link

10.11.1.1.1.2.1 s223:hasDCDifferentialVoltage

A Relation that associates an Electricity-DC medium with a differential voltage.

10.11.1.1.1.2.2 s223:hasDCPositiveVoltage

A Relation that associates an Electricity-DC medium with a positive polarity voltage.

10.11.1.1.1.2.3 s223:hasDCNegativeVoltage

A Relation that associates an Electricity-DC medium with a negative polarity voltage.

10.11.1.1.1.2.4 s223:hasDCZeroVoltage

A Relation that associates an Electricity-DC medium with a zero value voltage.

10.11.1.1.1.2.5 s223:DC-12V

This class and its enumerated subclasses represent all polarities of 12 volt DC electricity.

DC-12V Enumerations

Enumeration
12V-6V-Neg-6V-Pos
12V-12V-Neg
12V-12V-Pos

10.11.1.1.1.2.6 s223:DC-24V

This class and its enumerated subclasses represent all polarities of 24 volt DC electricity.

DC-24V Enumerations

Enumeration
24V-12V-Neg-12V-Pos
24V-24V-Neg
24V-24V-Pos

10.11.1.1.1.2.7 s223:DC-380V

This class and its enumerated subclasses represent all polarities of 380 volt DC electricity.

DC-380V Enumerations

Enumeration
380V-190V-Neg-190V-Pos
380V-380V-Neg
380V-380V-Pos

10.11.1.1.1.2.8 s223:DC-48V

This class and its enumerated subclasses represent all polarities of 48 volt DC electricity.

DC-48V Enumerations

Enumeration
48V-24V-Neg-24V-Pos
48V-48V-Neg
48V-48V-Pos

10.11.1.1.1.2.9 s223:DC-5V

This class and its enumerated subclasses represent all polarities of 5 volt DC electricity.

DC-5V Enumerations

Enumeration
5V-2.5V-Neg-2.5V-Pos
5V-5V-Neg
5V-5V-Pos

10.11.1.1.1.2.10 s223:DC-6V

This class and its enumerated subclasses represent all polarities of 6 volt DC electricity.

DC-6V Enumerations

Enumeration
6V-3V-Neg-3V-Pos
6V-6V-Neg
6V-6V-Pos

10.11.1.1.1.2.11 s223:DC-PoE

This class and its enumerated subclasses represent standardized types of PoE DC electricity.

DC-PoE Enumerations

Enumeration
PoE-802.3af-1
PoE-802.3at-2
PoE-802.3bt-3
PoE-802.3bt-4

10.11.1.1.1.3 s223:Electricity-Signal

This class and its enumerated subclasses represent the use of electricity for creating communication signals, and common communication protocols.

Electricity-Signal Enumerations

Enumeration
Signal-EIA485
Signal-IEC14908
Signal-Modulated (see Clause 10.11.1.1.1.3.2)
Signal-USB
Signal-WiredEthernet (see Clause 10.11.1.1.1.3.1)

10.11.1.1.1.3.1 s223:Signal-WiredEthernet

This class and its enumerated subclasses represent common wired Ethernet communication protocols.

Signal-WiredEthernet Enumerations

Enumeration
WiredEthernet-2.5GBASE-T
WiredEthernet-2.5GBASE-T1
WiredEthernet-5GBASE-T
WiredEthernet-5GBASE-T1
WiredEthernet-10BASE-T
WiredEthernet-10BASE-T1L
WiredEthernet-10BASE-T1S
WiredEthernet-10GBASE-T
WiredEthernet-10GBASE-T1
WiredEthernet-25GBASE-T
WiredEthernet-40GBASE-T
WiredEthernet-100BASE-T1
WiredEthernet-100BASE-TX
WiredEthernet-1000BASE-T

Enumeration
WiredEthernet-1000BASE-T1

10.11.1.1.1.3.2 s223:Signal-Modulated

This class and its enumerated subclasses represent common analog communication protocols.

Signal-Modulated Enumerations

Enumeration
Modulated-0-10V
Modulated-4-20mA
Modulated-Resistive

10.11.1.1.2 s223:Constituent-EM

This class and its enumerated subclasses represent electromagnetic energy at commonly defined frequency ranges.

Constituent-EM Enumerations

Enumeration
EM-Light (see Clause 10.11.1.1.2.1)
EM-Microwave
EM-RF (see Clause 10.11.1.1.2.2)

10.11.1.1.2.1 s223:EM-Light

This class and its enumerated subclasses represent light at commonly defined frequency or wavelength ranges.

EM-Light Enumerations

Enumeration
Light-Infrared (see Clause 10.11.1.1.2.1.1)
Light-Ultraviolet
Light-Visible

10.11.1.1.2.1.1 s223:Light-Infrared

This class and its enumerated subclasses represent the use of electromagnetic energy in the infrared frequency range for multiple purposes, including communication signals.

Light-Infrared Enumerations

Enumeration
Infrared-Signal (see Clause 10.11.1.1.2.1.1.1)

10.11.1.1.2.1.1.1 s223:Infrared-Signal

This class and its enumerated subclasses represent common infrared communication protocols.

Infrared-Signal Enumerations

Enumeration
Signal-FiberEthernet (see Clause 10.11.1.1.2.1.1.1)

10.11.1.1.2.1.1.1.1 s223:Signal-FiberEthernet

This class and its enumerated subclasses represent common fiber Ethernet communication protocols.

Signal-FiberEthernet Enumerations

Enumeration
FiberEthernet-1X9
FiberEthernet-300PIN
FiberEthernet-CFP
FiberEthernet-CFP2
FiberEthernet-CFP4
FiberEthernet-CPAK
FiberEthernet-CXP
FiberEthernet-GBIC
FiberEthernet-QSFP
FiberEthernet-QSFP+
FiberEthernet-QSFP28
FiberEthernet-SFF
FiberEthernet-SFP
FiberEthernet-SFP+
FiberEthernet-X2
FiberEthernet-XENPAK
FiberEthernet-XFP

10.11.1.1.2.2 s223:EM-RF

This class and its enumerated subclasses represent the use electromagnetic energy in the radio frequency range for multiple purposes, including communication signals.

EM-RF Enumerations

Enumeration
RF-Signal (see Clause 10.11.1.1.2.2.1)

10.11.1.1.2.2.1 s223:RF-Signal

This class and its enumerated subclasses represent the use of radio frequency for creating communication signals, and common communication protocols. The radio spectrum of frequencies (RF-Signal) is divided into bands (i.e., subclasses) with conventional names designated by the International Telecommunication Union (e.g., UHF for Ultra High Frequency).

RF-Signal Enumerations

Enumeration
Signal-EHF
Signal-ELF
Signal-HF
Signal-LF
Signal-MF
Signal-SHF
Signal-SLF
Signal-THF
Signal-UHF (see Clause 10.11.1.1.2.2.1.1)
Signal-ULF
Signal-VHF
Signal-VLF
Signal-Wideband (see Clause 10.11.1.1.2.2.1.2)

10.11.1.1.2.2.1.1 s223:Signal-UHF

RF Signal Ultra High Frequency 300 MHz to 3 GHz

10.11.1.1.2.2.1.1.1 s223:UHF-LicensedBand

This class represents communication protocols that use radio frequencies in licensed bands of the UHF spectrum.

10.11.1.1.2.2.1.1.2 s223:UHF-ISMBand

This class and its enumerated subclasses represent communication protocols that use radio frequencies that are reserved internationally for license-free support of Industrial, Scientific, and Medical applications.

UHF-ISMBand Enumerations

Enumeration
ISMBand-BluetoothLE
ISMBand-IEEE802.11
ISMBand-IEEE802.15.4
ISMBand-LoRaWAN

Enumeration
ISMBand-NFC
ISMBand-RFID

10.11.1.1.2.2.1.2 s223:Signal-Wideband

Signal-Wideband

10.11.1.1.2.2.1.2.1 s223:Wideband-CATV

The Community Antenna Television communication protocol that is used to deliver cable TV service over CoaxialCable or FiberOpticCable communication networks.

10.11.1.1.2.2.1.2.2 s223:Wideband-DOCSIS

The global standard Data Over Cable Service Interface Specification communication protocol that is used to deliver high-speed internet service over CoaxialCable communication networks.

10.11.1.1.3 s223:Constituent-NOX

This class and its enumerated subclasses represent common Nitrogen Oxides (NOx).

Constituent-NOX Enumerations

Enumeration
NOX-NO
NOX-NO2

10.11.1.1.4 s223:Constituent-Refrigerant

This class and its enumerated subclasses represent commonly used refrigerants. The composition of the refrigerants is defined in ASHRAE Standard 34 and ISO 817.

Constituent-Refrigerant Enumerations

Enumeration
Refrigerant-R-22
Refrigerant-R-32
Refrigerant-R-123
Refrigerant-R-134A
Refrigerant-R-290
Refrigerant-R-404A
Refrigerant-R-407A
Refrigerant-R-407C
Refrigerant-R-407F
Refrigerant-R-410A
Refrigerant-R-422A

Enumeration
Refrigerant-R-422C
Refrigerant-R-422D
Refrigerant-R-427A
Refrigerant-R-438A
Refrigerant-R-444A
Refrigerant-R-445A
Refrigerant-R-448A
Refrigerant-R-449A
Refrigerant-R-450A
Refrigerant-R-454A
Refrigerant-R-454C
Refrigerant-R-455A
Refrigerant-R-457A
Refrigerant-R-459B
Refrigerant-R-507
Refrigerant-R-513A
Refrigerant-R-516A
Refrigerant-R-600A
Refrigerant-R-717
Refrigerant-R-744
Refrigerant-R-1234yf
Refrigerant-R-1234ze

10.11.1.2 s223:Medium-Mix

This class and its subclasses represent substances that are composed of constituents. The components of a Medium-Mix can be modeled using the relations `composedOf` and `ofConstituent`. See Figure 10-8a and Figure 10-8b.

Figure 10-8a shows `GlycolSolution-30Percent`, itself a subclass of `Water-GlycolSolution`, `Fluid-Water`, and `Mix-Fluid`, with a *Water Concentration* property referencing 70% `Constituent-H2O` by the relation `ofConstituent` and a *Glycol Concentration* property referencing 30% `Constituent-Glycol` also by the relation `ofConstituent`.

Figure 10-8b shows `PowerAndSignal-PoE`, itself a subclass of `Mix-PowerAndSignal`, composed of a *Power* Property referencing `Electricity-DC` and a *Communications* Property referencing `Signal-WiredEthernet`.

Medium-Mix Enumerations

Enumeration
Mix-Fluid (see Clause 10.11.1.2.1)
Mix-PowerAndSignal (see Clause 10.11.1.2.2)

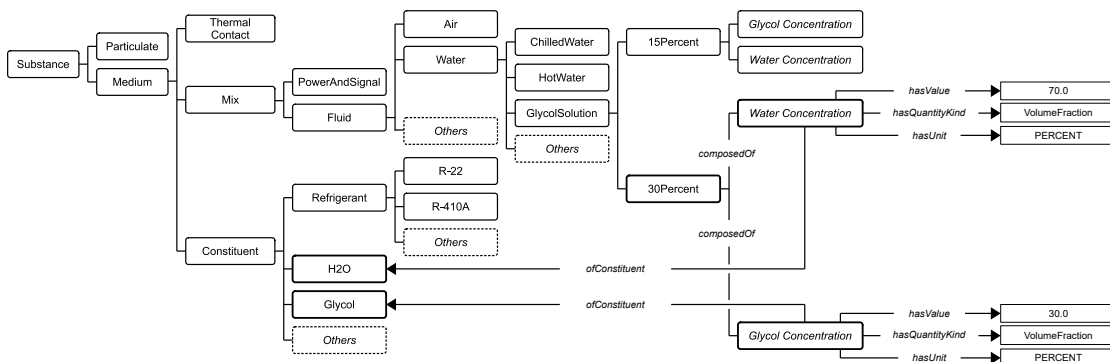

Figure 10-8a, Constituents of 30% Glycol Solution

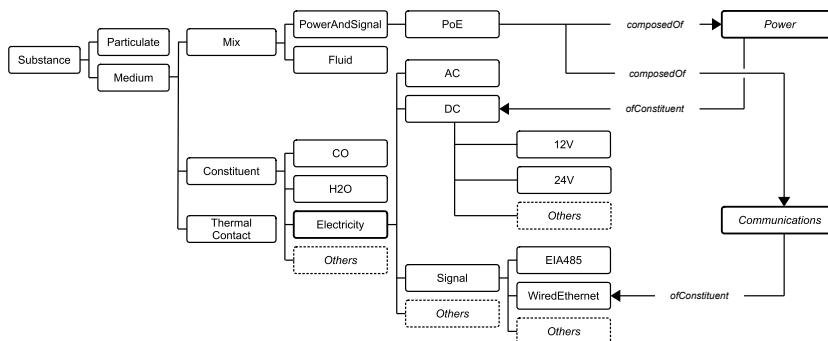

Figure 10-8b, Constituents of Power over Ethernet

Figure 10-8.

Related Constraints

Description	Link
A Medium-Mix shall be associated with zero or more Property types that identify and characterize its constituents using the relation <code>composedOf</code> . The Property identifies the constituent using the relation <code>ofConstituent</code> . If appropriate, a <code>QuantifiableProperty</code> may be used to also specify the amount of the constituent using the relations <code>qudt:hasQuantityKind</code> , <code>qudt:hasUnit</code> , and <code>hasValue</code> . For example, see Clause 10.11.1.2.1.1.1.	Link

10.11.1.2.1 s223:Mix-Fluid

This class and its enumerated subclasses represent substances that are commonly used to convey liquids or gases.

Mix-Fluid Enumerations

Enumeration
Fluid-Air
Fluid-NaturalGas
Fluid-Oil
Fluid-Water (see Clause 10.11.1.2.1.1)

10.11.1.2.1.1 s223:Fluid-Water

This class and its enumerated subclasses represent water and aqueous solutions in various states.

Fluid-Water Enumerations

Enumeration
Water-ChilledWater
Water-GlycolSolution (see Clause 10.11.1.2.1.1.1)
Water-HotWater
Water-Steam

10.11.1.2.1.1.1 s223:Water-GlycolSolution

This class and its enumerated subclasses represent common concentrations of water-glycol solution.

Water-GlycolSolution Enumerations

Enumeration
GlycolSolution-15Percent
GlycolSolution-30Percent

Related Constraints

Description	Link
A Water-GlycolSolution shall be associated with at least two QuantifiablePropertys using the relation composedOf. These characterize the constituents of a Water-GlycolSolution.	Link
A Water-GlycolSolution shall be associated with zero or more QuantifiablePropertys with a QuantityKind of Temperature using the relation hasFreezingPoint.	Link

Description	Link
One of the constituents of a <i>Water-GlycolSolution</i> shall be a <i>Constituent-Glycol</i> .	Link
One of the constituents of a <i>Water-GlycolSolution</i> shall be a <i>Constituent-H2O</i> .	Link

10.11.1.2.1.1.1 s223:hasFreezingPoint

The relation *hasFreezingPoint* is used to associate a freezing point with a glycol solution, but could be used with other *Mediums* as appropriate.

10.11.1.2.2 s223:Mix-PowerAndSignal

This class and its enumerated subclasses represent substances that are used to convey the combination of electrical power and electrical communication signals.

Mix-PowerAndSignal Enumerations

Enumeration
<i>PowerAndSignal-PoE</i>

10.11.2 s223:Substance-Particulate

This class and its enumerated subclasses represent common size thresholds of interest for particulate matter that is suspended in a medium in a way that maintains the physical and chemical properties of the medium.

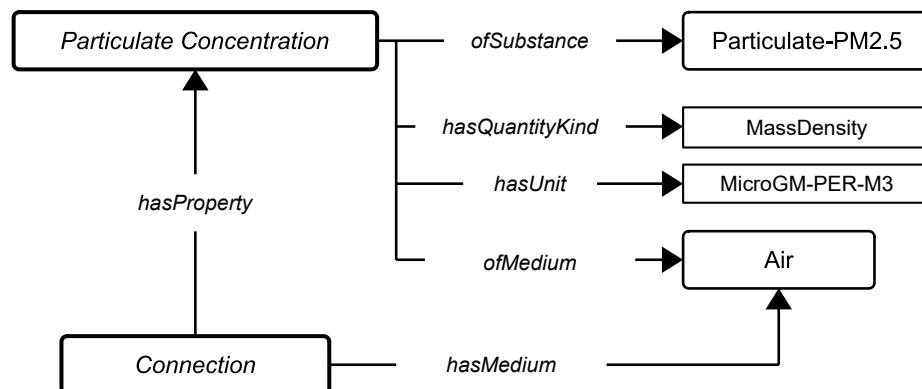

Figure 10-9. Particulate Concentration

Figure 10-9 shows an instance of a *Connection* with *hasMedium* referencing *Fluid-Air* that has a *Property Particulate Concentration* of particles with a diameter of 2.5 micrometres (0.0025 mm) or smaller in units of micrograms per cubic meter.

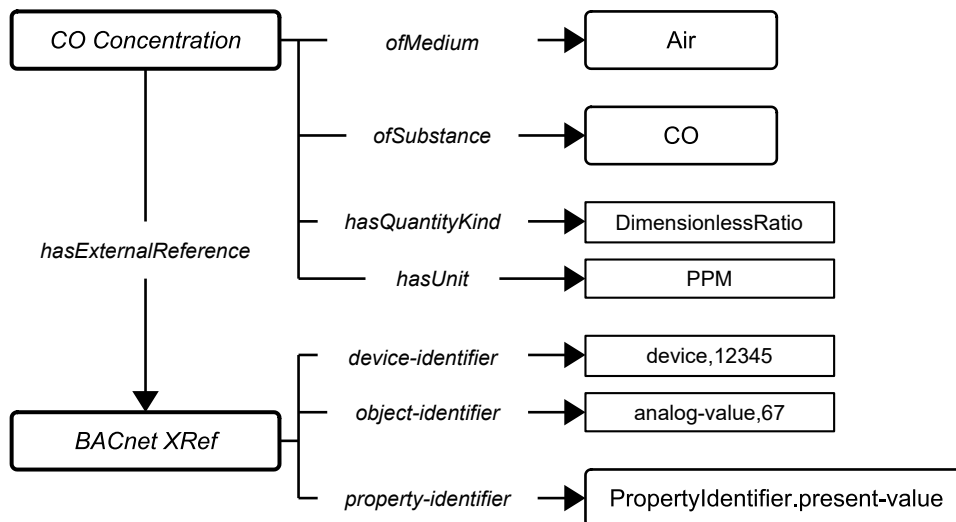

Figure 10-10. Carbon Monoxide Concentration

Figure 10-10 shows an instance of a Property *CO Concentration* with *ofSubstance* referencing carbon monoxide Constituent-CO and *ofMedium* referencing Fluid-Air measured in parts-per-million. This figure also shows that the value of this Property can be obtained by using the BACnet protocol via the external reference to get the present-value of analog-value, 67 in the device with an instance number 12345.

Substance-Particulate Enumerations

Enumeration
Particulate-PM1.0
Particulate-PM2.5
Particulate-PM10.0
Particulate-Smoke

10.11.3 s223:Substance-Soot

Carbon particles resulting from the incomplete combustion of hydrocarbons. Soot is considered a hazardous substance with carcinogenic properties.

11 PROPERTIES AND VALUES

Things have properties, and properties have values.

11.1 s223:Property

An attribute, quality, or characteristic of a feature of interest.

The Property class is the parent of all variations of a Property, which are:

- **ActuatableProperty**, a subclass of Property that can be modified by user or machine outside of the model (typically command);
- **ObservableProperty**, a subclass of Property that are observed (typically measures);
- **EnumerableProperty**, a subclass of Property defined by EnumerationKind; and
- **QuantifiableProperty**, a subclass of Property defined by numerical values.

And their subclass combinations:

- **QuantifiableActuatableProperty**,
- **QuantifiableObservableProperty**,
- **EnumeratedObservableProperty**, and
- **EnumeratedActuatableProperty**.

A **QuantifiableProperty** (or subclass thereof) shall always be associated with a **Unit** and a **QuantityKind**, either explicitly from the Property, or through the associated **Value**. If the **Unit** is defined, the SHACL reasoner (if invoked) will figure out and assert a **QuantityKind** if it is unambiguous.

Enumerable properties shall be associated with an **EnumerationKind**. Different flavors of properties are shown in Figure 11-1.

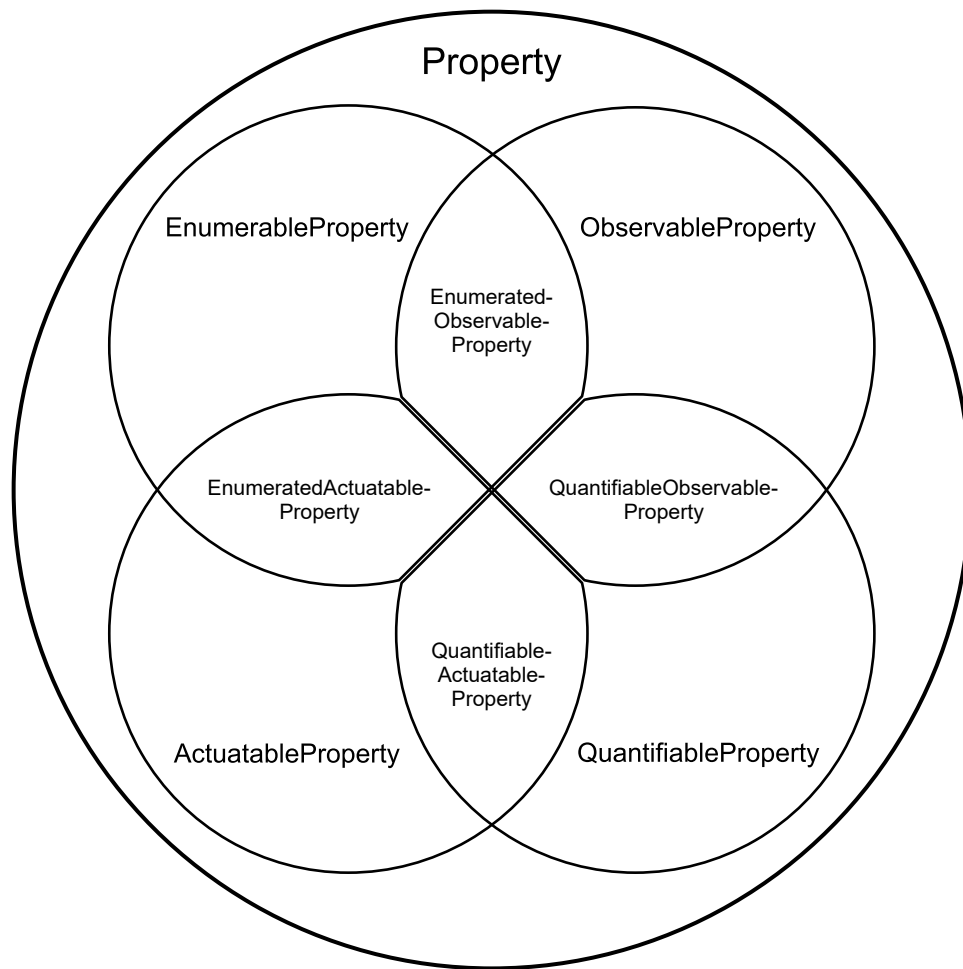

Figure 11-1. Different flavors of Properties

A Property instance that is not an instance of one of the subclasses is unconstrained with respect to its value.

Related Constraints

Description	Link
A Property cannot be declared an instance of both an <code>ActuatableProperty</code> and an <code>ObservableProperty</code> .	Link
A Property must not be observed (set) by more than one entity.	Link
A Property must not have both a <code>hasExternalReference</code> and a <code>hasValue</code> relation.	Link
A Property must not have both a <code>hasInternalReference</code> and a <code>hasExternalReference</code> relation.	Link
A Property must not have both a <code>hasInternalReference</code> and a <code>hasValue</code> relation.	Link
A Property shall be associated with at most one <code>EnumerationKind-Substance</code> using the relation <code>ofSubstance</code> .	Link
A Property shall be associated with at most one <code>Function</code> using the inverse of the relation <code>hasOutput</code> .	Link
A Property shall be associated with at most one <code>Substance-Medium</code> using the relation <code>ofMedium</code> .	Link
A Property shall be associated with at most one other Property using the relation <code>hasInternalReference</code> .	Link
A Property shall be associated with at most one other Property using the relation <code>isInternalReferenceOf</code> .	Link
A Property shall be associated with at most one value using the relation <code>hasValue</code> to provide a static value in the model. It is not meant for real-time value (see Clause 11.19).	Link
A Property shall be associated with zero or more <code>EnumerationKinds</code> using the relation <code>hasAspect</code> .	Link
A Property shall be associated with zero or more <code>ExternalReferences</code> using the relation <code>hasExternalReference</code> .	Link
If a Property has an <code>ofSubstance</code> relation, it should also have an <code>ofMedium</code> relation.	Link
If an incoming relation <code>composedOf</code> exists, then the Property must have a declared substance using the relation <code>ofConstituent</code> .	Link

11.2 s223:ActuatableProperty

The term “actuatable” implies that writing to the `ActuatableProperty` value will directly trigger a physical actuation by either an `Actuator` or `Equipment`. In contrast, the term “observable” (see Clause 11.3) implies that reading the `ObservableProperty` value will return the result of a physical observation.

Related Constraints

Description	Link
An ActuatableProperty normally is referred to by Equipment using the relation actuatedByProperty.	Link

11.3 s223:ObservableProperty

The term “observable” implies that reading the ObservableProperty value will return the result of a physical observation, usually by a Sensor. In contrast, the term “actuatable” (see Clause 11.2) implies that writing to the ActuatableProperty value will directly trigger a physical actuation.

Related Constraints

Description	Link
An ObservableProperty is usually referred to by a Sensor using the relation observes.	Link

11.4 s223:EnumerableProperty

An EnumerableProperty is a Property with an enumerated (fixed) set of possible values.

Related Constraints

Description	Link
An EnumerableProperty shall be associated with exactly one EnumerationKind using the relation hasEnumerationKind.	Link
Checks for valid enumeration value consistent with the stated EnumerationKind.	Link

11.4.1 s223:hasEnumerationKind

A Relation that associates an EnumerableProperty with a class of enumeration values. This is used to, for example, identify what kind of substance is transported along a Connection or which day of the week a setpoint is active.

11.5 s223:QuantifiableProperty

This class is for quantifiable values that describe an object (System, Equipment, etc.) that are typically static (hasValue). That is, they are neither measured nor specified in the course of operations.

Related Constraints

Description	Link
A QuantifiableProperty shall be associated with at most one Boolean value using the relation qudt:isDeltaQuantity. If the relation qudt:isDeltaQuantity has a value of true, the associated value should be interpreted as a difference reading, such	Link

Description	Link
as a temperature difference. This is needed to distinguish between a temperature reading and a temperature difference reading, which affects unit conversion calculations.	
A QuantifiableProperty shall be associated with at most one Unit using the relation qudt:hasUnit.	Link
A QuantifiableProperty shall be associated with exactly one QuantityKind using the relation qudt:hasQuantityKind.	Link
A QuantifiableProperty shall be associated with zero or more EnumerablePropertyts using the relation hasAlarmStatus.	Link
A QuantifiableProperty shall be associated with zero or more qudt:QuantityValues using the relation qudt:quantityValue. This allows to express multiple equivalent combinations of a Unit and value. However, typically a QuantifiableProperty is associated with a static decimal value using hasValue, along with a single Unit and QuantityKind.	Link
A QuantifiableProperty shall be associated with zero or more other QuantifiablePropertyts using the relation hasDeadband.	Link
A QuantifiableProperty shall be associated with zero or more other QuantifiablePropertyts using the relation hasSetpoint. This can be used to indicate the desired value which the control process is trying to maintain.	Link
A QuantifiableProperty shall be associated with zero or more other QuantifiablePropertyts using the relation hasThreshold.	Link
A QuantifiableProperty should use hasValue instead of qudt:value.	Link
Checks for consistent dimension vectors for a QuantityKind and the Unit	Link
This QuantifiableProperty and the associated deadband use non-commensurate Units.	Link
This QuantifiableProperty and the associated setpoint use non-commensurate Units.	Link
This QuantifiableProperty and the associated threshold use non-commensurate Units.	Link
This QuantifiableProperty and the deadband associated with it have non-commensurate QuantityKinds.	Link
This QuantifiableProperty and the setpoint associated with it have non-commensurate QuantityKinds.	Link
This QuantifiableProperty and the threshold associated with it have non-commensurate QuantityKinds.	Link
This QuantifiableProperty cannot have a value without a Unit.	Link
This QuantifiableProperty uses a different Unit than the deadband associated with it.	Link
This QuantifiableProperty uses a different Unit than the setpoint associated with it.	Link

Description	Link
This QuantifiableProperty uses a different Unit than the threshold associated with it.	Link

Related Inference Rules

Description	Link
Infer the hasAspect s223:Aspect-Deadband for properties referred to by hasDeadband	Link
Infer the hasAspect s223:Aspect-Setpoint for properties referred to by hasSetpoint	Link
Infer the hasAspect s223:Aspect-Threshold for properties referred to by hasThreshold	Link
Infer the hasQuantityKind relation if it is unambiguous.	Link

11.5.1 s223:hasAlarmStatus

A Relation that associates an EnumerableProperty that describes an Alarm or Status with a QuantifiableProperty.

11.5.2 s223:hasDeadband

This relation binds a control setpoint to the QuantifiableProperty indicating the range of values within which a sensed variable can vary without indicating a condition has changed.

11.5.3 s223:hasSetpoint

A Relation that associates a control setpoint with the QuantifiableProperty indicating the desired value which the control process is trying to maintain.

11.5.4 s223:hasThreshold

A Relation that associates a threshold with the QuantifiableProperty indicating a specific value at which an action may be taken, distinguished from an offset or a range.

11.6 s223:QuantifiableActuableProperty

This class is for instances of QuantifiableProperty for which numerical values are specified to be modifiable by a user or a machine outside of the model, like a setpoint.

11.7 s223:QuantifiableObservableProperty

This class is for instances of QuantifiableProperty for which numerical values are observed, like a temperature reading or a voltage measure.

11.8 s223:EnumeratedObservableProperty

An EnumeratedObservableProperty is a Property with an enumerated (fixed) set of possible values that cannot be changed (can only be observed).

11.9 s223:EnumeratedActuableProperty

An EnumeratedActuableProperty is a Property with an enumerated (fixed) set of possible values that can be changed (actuated).

11.10 s223:hasValue

A Relation that associates something with a fixed value, as opposed to a computed, measured, or externally derived value.

11.11 qudt:hasUnit

A reference to the unit of measure of a QuantifiableProperty of interest, such as DEG_C.

11.12 qudt:hasQuantityKind

A reference to the QuantityKind of a QuantifiableProperty of interest, such as Temperature.

11.13 s223:hasAspect

hasAspect is used to establish the context of a Property. The value must be an instance of EnumerationKind. For example, if a Property has a Temperature value of 45.3, the hasAspect relation is used to state what that represents, such as a Temperature limit during working hours, etc. A Property can have any number of hasAspect relations as needed to establish the context.

11.14 s223:ofSubstance

A Relation that associates a Property being observed by a Sensor with the EnumerationKind-Substance it characterizes within a specific Substance-Medium. For example, to denote the concentration of a EnumerationKind-Substance in a Substance-Medium, ofSubstance is used. Typically, there is also an ofMedium relation between the observed Property and the Substance-Medium, (see Figures 10-9 and 10-10). For example, to represent the concentration of CO2 in air, we use ofSubstance to relate to CO2 and ofMedium to relate to air. The term ofSubstance is broad enough to include situations where a sensor is used to detect constituents that should not be present in a medium, such as ammonia in air. Therefore, ofSubstance is used to indicate the substance of interest, while ofConstituent would indicate a constituent that is normally present in the composition of the mix.

11.15 s223:ofMedium

A Relation that associates a Property with the specific Medium it describes. A Property corresponding to the temperature of a medium would be associated with this medium using the relation ofMedium.

11.16 s223:ofConstituent

A Relation that associates a Property that characterizes a Medium-Mix with one of the constituents of that mix. (e.g., Fluid-Water composedOf Property ofConstituent Constituent-H2O.

11.17 s223:composedOf

The relation `composedOf` is used to indicate what substances constitute a material. Allowable values are instances of `Property` that in turn identify constituents defined in `Medium-Constituent` (see Clause 10.11.1.1) via the relation `ofConstituent`.

11.18 s223:ExternalReference

`ExternalReference` is an abstract class that represents a thing that contains API or protocol parameter values necessary to associate a `Property` with a value.

11.18.1 s223:BACnetExternalReference

An `ExternalReference` that contains BACnet protocol parameter values necessary to associate a `Property` with a value.

Related Constraints

Description	Link
A <code>BACnetExternalReferenceShape</code> shall be associated with at most one BACnet device identifier using the relation <code>bacnet:device-identifier</code> .	Link
A <code>BACnetExternalReferenceShape</code> shall be associated with at most one BACnet device name using the relation <code>bacnet:device-name</code> .	Link
A <code>BACnetExternalReferenceShape</code> shall be associated with at most one BACnet object identifier using the relation <code>bacnet:object-identifier</code> .	Link
A <code>BACnetExternalReferenceShape</code> shall be associated with at most one BACnet object name using the relation <code>bacnet:object-name</code> .	Link
A <code>BACnetExternalReferenceShape</code> shall be associated with at most one index for reading items from a BACnet property that is an array using the relation <code>bacnet:property-array-index</code> .	Link
A <code>BACnetExternalReferenceShape</code> shall be associated with at most one priority for writing values using the relation <code>bacnet:priority-for-writing</code> .	Link
A <code>BACnetExternalReferenceShape</code> shall be associated with at most one string value using the relation <code>bacnet:property-identifier</code> . The string value shall be either a decimal number or exactly equal to the ASHRAE 135-2024 Clause 21 identifier text of <code>BACnetPropertyIdentifier</code> . If it is omitted, it defaults to “present-value”, except for BACnet File objects, where absence of <code>bacnet:property-identifier</code> refers to the entire content of the file accessed with Stream Access.	Link

11.18.1.1 bacnet:device-name

The name of the BACnet device being referenced, more formally the `Object_Name` property of the device object within the BACnet device. See ASHRAE 135-2024 Clause 12.11.2.

11.18.1.2 bacnet:device-identifier

The Object_Identifier property of the device object within the BACnet device. See ASHRAE 135-2024 Clause 12.11.1.

11.18.1.3 bacnet:object-name

The Object_Name property of the object being referenced. For example, for the object name of an Analog Value Object, see ASHRAE 135-2024 Clause 12.4.2.

11.18.1.4 bacnet:object-identifier

The Object_Identifier property of the object being referenced. For example, for the object identifier of an Analog Value Object, see ASHRAE 135-2024 Clause 12.4.1.

11.18.1.5 bacnet:property-identifier

The Object_Identifier Property of the object being referenced. For example, for the object identifier of an Analog Value Object, see ASHRAE 135-2024 Clause 12.4.1.

11.18.1.6 bacnet:property-array-index

If the property identified is of datatype array, this optional property of type Unsigned shall indicate the array index of the element of the Property referenced by the ReadProperty service or the Read Access Specification of the ReadPropertyMultiple service. If the bacnet:property-array-index is omitted, this shall mean that the entire array shall be referenced. See ASHRAE 135-2024 Clause 15.5.1.1.3 and Clause 15.7.1.1.1.

11.18.1.7 bacnet:priority-for-writing

This parameter shall be an integer in the range 1..16, which indicates the priority assigned to the WriteProperty service. If an attempt is made to write to a commandable property without specifying the bacnet:priority-for-writing, a default priority of 16 (the lowest priority) shall be assumed. If an attempt is made to write to a property that is not commandable with a specified priority, the priority shall be ignored. See ASHRAE 135-2024 Clause 15.9.1.1.5.

11.19 s223:hasExternalReference

A Relation that associates a Property with an external telemetry source.

11.20 s223:hasInternalReference

A Relation that associates a Property with another equivalent Property. For example, a Property that represents a Zone temperature could have at most one hasInternalReference relation to another Property that is a temperature measurement from one room in the zone (see Figure 11-2).

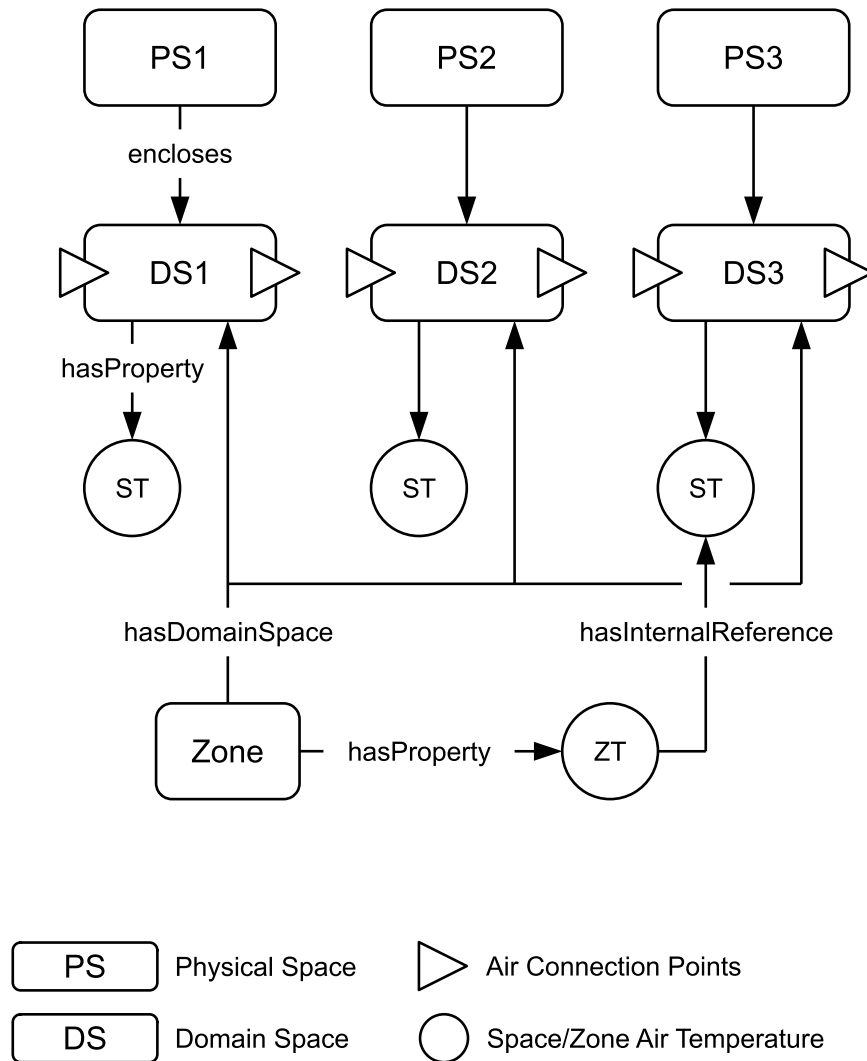

Figure 11-2. Zone Internal Reference.

Another use of `hasInternalReference` is to make a Property of a piece of equipment visible as a Property of a piece of containing equipment. This is illustrated in Figure 11-3.

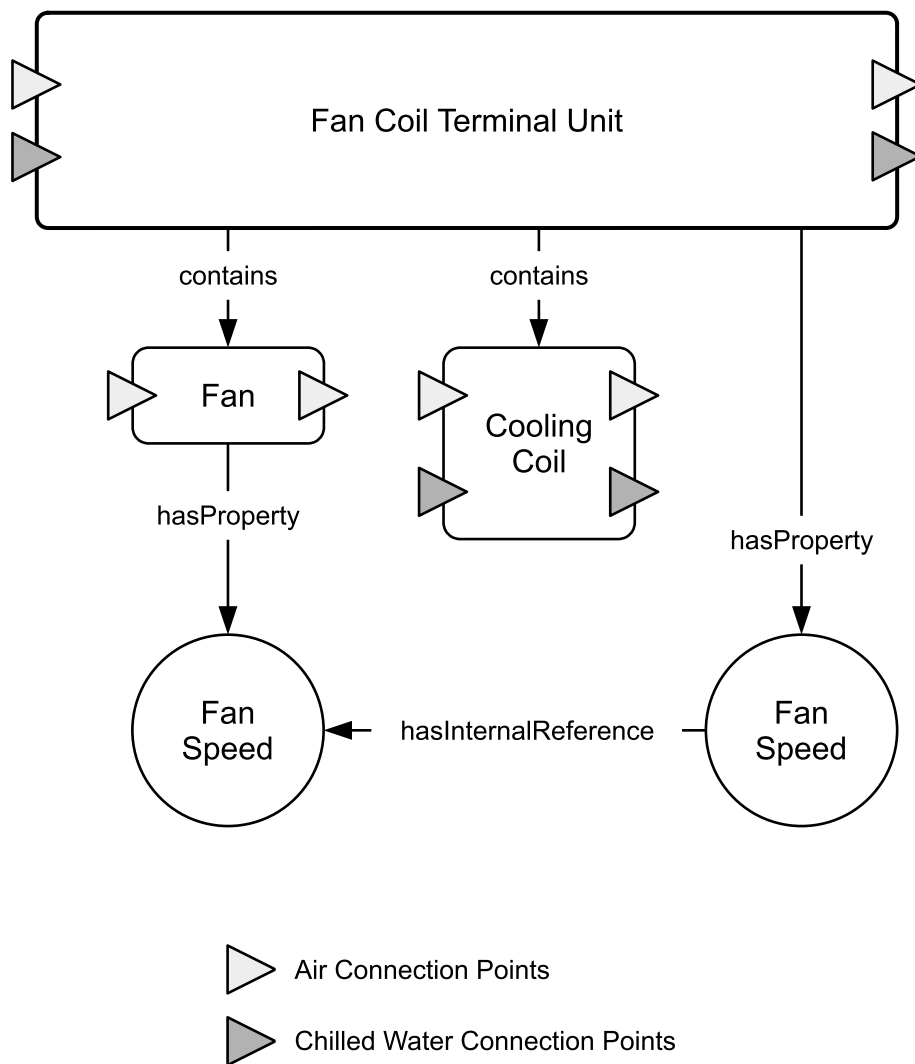

Figure 11-3. Equipment Containment.

Note that the `hasInternalReference` relation is transitive.

11.21 `s223:isInternalReferenceOf`

The inverse of the relation `hasInternalReference` (see Clause 11.20).

12 REFERENCE FOR EQUIPMENT

This section contains component model templates for equipment that is commonly found in buildings.

12.1 s223:AirHandlingUnit

A piece of Equipment consisting of a fan or fans and other equipment necessary to perform one or more of the following functions: circulating, filtration, heating, cooling, heat recovery, humidifying, dehumidifying, and mixing of air.

Related Constraints

Description	Link
An AirHandlingUnit shall have at least one inlet using the medium Fluid-Air.	Link
An AirHandlingUnit shall have at least one outlet using the medium Fluid-Air.	Link

Related Inference Rules

Description	Link
If an instance of s223:AirHandlingUnit matches the constraints defined by g36: DualFanDualDuctAirHandlingUnit, it will be declared as an instance of that class.	Link
If an instance of s223:AirHandlingUnit matches the constraints defined by g36:MultipleZoneVAVAirHandlingUnit and has a common economizer/minimum outdoor air damper, it will be declared as an instance of this class.	Link
If an instance of s223:AirHandlingUnit matches the constraints defined by g36:MultipleZoneVAVAirHandlingUnit and has a relief damper, it will be declared as an instance of this class.	Link
If an instance of s223:AirHandlingUnit matches the constraints defined by g36:MultipleZoneVAVAirHandlingUnit and has a relief fan, it will be declared as an instance of this class.	Link
If an instance of s223:AirHandlingUnit matches the constraints defined by g36:MultipleZoneVAVAirHandlingUnit and has a return fan, it will be declared as an instance of this class.	Link
If an instance of s223:AirHandlingUnit matches the constraints defined by g36:MultipleZoneVAVAirHandlingUnit, it will be declared as an instance of that class.	Link
If an instance of s223:AirHandlingUnit matches the constraints defined by g36:MultipleZoneVAVAirHandlingUnit-OADandAFMS, it will be declared as an instance of that class.	Link
If an instance of s223:AirHandlingUnit matches the constraints defined by g36:MultipleZoneVAVAirHandlingUnit-OADandDP, it will be declared as an instance of that class.	Link

Description	Link
If an instance of s223:AirHandlingUnit matches the constraints defined by g36:SingleZoneVAVAirHandlingUnit and has a relief fan, it will be declared as an instance of this class.	Link
If an instance of s223:AirHandlingUnit matches the constraints defined by g36:SingleZoneVAVAirHandlingUnit and has a return fan, it will be declared as an instance of that class.	Link
If an instance of s223:AirHandlingUnit matches the constraints defined by g36:SingleZoneVAVAirHandlingUnit, it will be declared as an instance of that class.	Link
If an instance of s223:AirHandlingUnit matches the constraints defined by g36:SingleZoneVAVAirHandlingUnit-WithReliefDamperFan, it will be declared as an instance of that class.	Link

12.2 s223:AirHeatExchanger

A piece of Equipment that transfers heat from one air stream to another while keeping the two media separate.

Related Constraints

Description	Link
An AirHeatExchanger shall have at least two inlets using the medium Fluid-Air, each paired with an outlet.	Link
An AirHeatExchanger shall have at least two outlets using the medium Fluid-Air, each paired with an inlet.	Link
An AirHeatExchanger shall have no bidirectional connection points.	Link

Related Inference Rules

Description	Link
Infer the hasRole s223:Role-HeatTransfer relation for every instance of the listed targetClass values.	Link

12.3 s223:Battery

A piece of Equipment that stores a defined amount of chemical energy that can be converted to electrical energy via a chemical process. This process, typically referred to as discharging, produces a specific electrical voltage and current.

Related Constraints

Description	Link
A Battery shall have at least one outlet or bidirectional connection point using the medium Constituent-Electricity.	Link

12.4 s223:Boiler

A piece of Equipment that uses fuel or electricity to heat water or other fluids and supply steam or hot water for heating, humidification, or other applications.

Related Constraints

Description	Link
A Boiler shall have at least one inlet using the medium Fluid-Water.	Link
A Boiler shall have at least one outlet using the medium Fluid-Water.	Link

12.5 s223:ChilledBeam

A piece of Equipment with a colder surface temperature where air passes through, and air movement is induced in the room to achieve cooling. Cooling medium is generally water.

Related Constraints

Description	Link
A ChilledBeam shall at least have the role Role-Cooling.	Link
A ChilledBeam shall have at least one bidirectional connection point using the medium Fluid-Air.	Link
A ChilledBeam shall have at least one inlet using the medium Fluid-Water.	Link
A ChilledBeam shall have at least one outlet using the medium Fluid-Water.	Link

Related Inference Rules

Description	Link
A ChilledBeam must always have the role Role-Cooling	Link
Infer the hasRole s223:Role-HeatTransfer relation for every instance of the listed targetClass values.	Link

12.6 s223:Chiller

A piece of Equipment that removes heat from a liquid coolant via a vapor-compression, adsorption refrigeration, or absorption refrigeration cycles.

Related Constraints

Description	Link
A Chiller shall have at least one inlet using the medium Fluid-Water.	Link
A Chiller shall have at least one outlet using the medium Fluid-Water.	Link

12.7 s223:ClothesWasher

A piece of Equipment that automatically cleans a load of textiles (e.g., clothing, bedding).

Related Constraints

Description	Link
A ClothesWasher shall have at least one inlet using the medium Constituent-Electricity.	Link
A ClothesWasher shall have at least one inlet using the medium Fluid-Water.	Link
A ClothesWasher shall have at least one outlet using the medium Fluid-Water.	Link

12.8 s223:CoffeeMaker

A piece of Equipment that automatically brews coffee.

Related Constraints

Description	Link
A CoffeeMaker shall have at least one inlet using the medium Constituent-Electricity.	Link

12.9 s223:Coil

A piece of Equipment consisting of a pipe or tube that is formed into a helical or serpentine shape, may or may not be finned, and is used in cooling or heating equipment.

A Coil shall conform to exactly one of the following patterns:

- **Pattern 1:**
 - The Coil has exactly two inlet connection points using the medium Mix-Fluid, with exactly one being Fluid-Air.
 - The Coil has exactly two outlet connection points using the medium Mix-Fluid, with exactly one being Fluid-Air.
- **Pattern 2:**
 - The Coil has exactly one inlet connection point using the medium Mix-Fluid.
 - The Coil has exactly one outlet connection point using the medium Mix-Fluid.
 - The Coil has one or two bidirectional connection points using the medium Mix-Fluid or Medium-ThermalContact.
- **Pattern 3:**
 - The Coil has exactly three bidirectional connection points using the medium Mix-Fluid or Medium-ThermalContact.

Related Constraints

Description	Link
Pattern 1: A Coil shall have two inlets using the medium Mix-Fluid.	Link
Pattern 1: A Coil shall have two outlets using the medium Mix-Fluid.	Link
Pattern 1: For one of the two inlets the Fluid is Air.	Link
Pattern 1: For one of the two outlets the Fluid is Air.	Link
Pattern 2: A Coil shall have one inlet using the medium Mix-Fluid.	Link
Pattern 2: A Coil shall have one or two bidirectionals using the medium Mix-Fluid or Medium-ThermalContact.	Link
Pattern 2: A Coil shall have one outlet using the medium Mix-Fluid.	Link
Pattern 3: A Coil shall have three bidirectionals using the medium Mix-Fluid or Medium-ThermalContact.	Link

Related Inference Rules

Description	Link
Infer the hasRole s223:Role-HeatTransfer relation for every instance of the listed targetClass values.	Link

12.9.1 s223:CoolingCoil

A Coil that is specifically used to cool air.

Related Constraints

Description	Link
A CoolingCoil shall at least have the role Role-Cooling.	Link

Related Inference Rules

Description	Link
A CoolingCoil must always have the role Role-Cooling	Link
If an instance of s223:CoolingCoil matches the constraints defined by g36:ChilledWaterCoil, it will be declared as an instance of that class.	Link

12.9.2 s223:HeatingCoil

A Coil that is specifically used to heat air.

Related Constraints

Description	Link
A HeatingCoil shall at least have the role Role-Heating.	Link

Related Inference Rules

Description	Link
Heating coils must always have the role <code>Role-Heating</code>	Link
If an instance of <code>s223:HeatingCoil</code> matches the constraints defined by <code>g36:HotWaterCoil</code> , it will be declared as an instance of that class.	Link

12.10 s223:Compressor

A piece of Equipment that mechanically increases the pressure of a gas.

Related Constraints

Description	Link
A Compressor shall have at least one inlet.	Link
A Compressor shall have at least one outlet.	Link

12.11 s223:Computer

A piece of Equipment that can be programmed to automatically carry out sequences of arithmetic or logical operations (computation). Modern digital electronic computers can perform generic sets of operations known as programs. These programs enable computers to perform a wide range of tasks.

Related Constraints

Description	Link
A Computer shall have at least one inlet using the medium <code>Constituent-Electricity</code> .	Link

12.11.1 s223:PersonalComputer

A Computer designed primarily used by a single person.

Related Constraints

Description	Link
A <code>PersonalComputer</code> shall have at least one inlet using the medium <code>Constituent-Electricity</code> .	Link

12.11.2 s223:ServerComputer

A Computer that is primarily used by multiple people, or for the execution of tasks not directly coupled to human interaction.

Related Constraints

Description	Link
A ServerComputer shall have at least one inlet using the medium Constituent-Electricity.	Link

12.12 s223:ComputerPrinter

A piece of Equipment that processes an input electrical or RF signal, typically from a Computer, and outputs a durable representation of information, typically text and/or graphics, typically on paper.

Related Constraints

Description	Link
A ComputerPrinter shall have at least one inlet using the medium Constituent-Electricity.	Link
A ComputerPrinter shall have at least one inlet using the medium Electricity-Signal or EM-RF.	Link

12.13 s223:CoolingTower

A piece of Equipment that uses atmospheric air to cool warm water, generally by direct contact via evaporation.

Related Constraints

Description	Link
A CoolingTower shall have at least one inlet using the medium Fluid-Water.	Link
A CoolingTower shall have at least one outlet using the medium Fluid-Water.	Link

12.14 s223:CopyMachine

A piece of Equipment that processes an input of one or more durable representation(s) of information, typically text and/or graphics and typically on paper, and outputs one or more reproductions of the information for each input, typically on paper.

Related Constraints

Description	Link
A CopyMachine shall have at least one inlet using the medium Constituent-Electricity.	Link

12.15 s223:Damper

A piece of Equipment inserted into an air distribution system permitting modification of the air resistance of the system and consequently changing the airflow rate or shutting off the airflow.

Related Constraints

Description	Link
A Damper shall have at least one inlet using the medium Fluid-Air.	Link
A Damper shall have at least one outlet using the medium Fluid-Air.	Link

Related Inference Rules

Description	Link
If an instance of s223:Damper matches the constraints defined by g36:Damper, it will be declared as an instance of that class.	Link
If an instance of s223:Damper matches the constraints defined by g36:TwoPositionDamper, it will be declared as an instance of that class.	Link

12.16 s223:Dishwasher

A piece of Equipment that automatically cleans dishware, cookware, and cutlery.

Related Constraints

Description	Link
A Dishwasher shall have at least one inlet using the medium Constituent-Electricity.	Link
A Dishwasher shall have at least one inlet using the medium Fluid-Water.	Link
A Dishwasher shall have at least one outlet using the medium Fluid-Water.	Link

12.17 s223:Door

A piece of Equipment consisting of hinged, sliding, or revolving barrier at the entrance to a building or room.

Related Constraints

Description	Link
A Door shall have at least two bidirectional connection points using the medium Fluid-Air.	Link

12.18 s223:ElectricityBreaker

A piece of equipment that automatically opens an electric circuit automatically at a predetermined overcurrent, so as to prevent damage to the circuit, the equipment connected to the circuit, and the building containing the circuit.

Related Constraints

Description	Link
An ElectricityBreaker shall have at least one inlet using the medium Constituent-Electricity.	Link
An ElectricityBreaker shall have at least one outlet using the medium Constituent-Electricity.	Link

12.19 s223:ElectricClothesDryer

A piece of Equipment that automatically removes moisture from a load of textiles (e.g., clothing, bedding), typically after they are washed in a ClothesWasher.

Related Constraints

Description	Link
An ElectricClothesDryer shall have at least one inlet using the medium Constituent-Electricity.	Link

12.20 s223:ElectricCooktop

A piece of Equipment with a flat surface containing one or more heat sources designed for cooking with pots and pans.

Related Constraints

Description	Link
An ElectricCooktop shall have at least one inlet using the medium Constituent-Electricity.	Link

12.21 s223:ElectricEnergyConverter

A piece of Equipment that converts one form of electric power to another form of electric power.

Related Constraints

Description	Link
An ElectricEnergyConverter shall have at least two connection points using the medium Constituent-Electricity.	Link

12.21.1 s223:ElectricEnergyDCDCConverter

An ElectricEnergyConverter that transforms direct current (DC) electric power from one voltage to another voltage.

Related Constraints

Description	Link
An ElectricEnergyDCDCConverter shall have at least two connection points using the medium Electricity-DC.	Link

12.21.2 s223:ElectricEnergyInverter

An ElectricEnergyConverter that transforms direct current (DC) electric power to alternating current (AC) electric power, or vice versa.

Related Constraints

Description	Link
An ElectricEnergyInverter shall have at least one connection point using the medium Electricity-AC.	Link
An ElectricEnergyInverter shall have at least one connection point using the medium Electricity-DC.	Link

12.21.3 s223:ElectricEnergyTransformer

An ElectricEnergyConverter that transforms alternating current (AC) electric power from one voltage to another voltage.

Related Constraints

Description	Link
An ElectricEnergyTransformer shall have at least two connection points using the medium Electricity-AC.	Link

12.22 s223:ElectricityMeter

A piece of Equipment that contains at least one VoltageSensor and one ElectricCurrentSensor, and reports one or more properties of electricity. Example reported properties include the following QuantityKinds: Voltage, ElectricCurrent, ActiveEnergy, ActivePower, ReactivePower, ApparentPower, PowerFactor, and Frequency with unit Hertz. An ElectricityMeter may optionally contain a Function that represents the mathematical calculations of the reported properties of electricity.

Related Constraints

Description	Link
An ElectricityMeter shall contain a VoltageSensor and ElectricCurrentSensor with the same observation location.	Link
An ElectricityMeter shall contain at least one ElectricCurrentSensor.	Link
An ElectricityMeter shall contain at least one VoltageSensor.	Link
The medium observed by the sensors contained by an ElectricityMeter shall be a Constituent-Electricity.	Link
The observation location of the sensors contained by an ElectricityMeter shall be either a Connection or a ConnectionPoint.	Link

12.23 s223:ElectricityOutlet

A piece of Equipment that contains one or more receptacles for connecting electrical equipment to electrical power, typically via a plug and cord. Not to be confused with an OutletConnectionPoint with the medium Constituent-Electricity.

Related Constraints

Description	Link
An ElectricityOutlet shall have at least one outlet using the medium Constituent-Electricity.	Link
An ElectricityOutlet shall have exactly one inlet using the medium Constituent-Electricity.	Link

12.24 s223:ElectricOven

A piece of Equipment with an enclosed chamber designed for baking, roasting, and other cooking methods that rely on circulating heat.

Related Constraints

Description	Link
An ElectricOven shall have at least one inlet using the medium Constituent-Electricity.	Link

12.25 s223:ElectricResistanceElement

A piece of Equipment that provides electrical resistance heating, for example an electric heating coil within a Fan Coil Unit. It shall have one electricity InletConnectionPoint, and fit one of the following two patterns:

- Pattern 1: An ElectricResistanceElement shall have exactly one Bidirectional ConnectionPoint using the medium Mix-Fluid.
- Pattern 2: An ElectricResistanceElement shall have one inlet and one outlet using the medium Mix-Fluid.

Related Constraints

Description	Link
An ElectricResistanceElement shall at least have the role Role-Heating.	Link
An ElectricResistanceElement shall have at least one inlet using the medium Constituent-Electricity.	Link
Pattern 1: An ElectricResistanceElement shall have exactly one Bidirectional ConnectionPoint using the medium Mix-Fluid.	Link
Pattern 2: An ElectricResistanceElement shall have one inlet using the medium Mix-Fluid.	Link
Pattern 2: An ElectricResistanceElement shall have one outlet using the medium Mix-Fluid.	Link

Related Inference Rules

Description	Link
If an instance of s223:ElectricResistanceElement matches the constraints defined by g36:ElectricHeatingCoil, it will be declared as an instance of that class.	Link
Infer the hasRole s223:Role-HeatTransfer relation for every instance of the listed targetClass values.	Link

12.26 s223:ElectricWaterDispenser

A piece of Equipment that dispenses water and optionally heats and/or cools the water prior to dispensing.

Related Constraints

Description	Link
An ElectricWaterDispenser shall have at least one inlet using the medium Constituent-Electricity.	Link
An ElectricWaterDispenser shall have at least one inlet using the medium Fluid-Water.	Link

12.27 s223:ElectronicDisplay

A piece of Equipment that receives an input electrical signal and outputs information, typically text and/or graphics, in a visual form.

Related Constraints

Description	Link
An ElectronicDisplay shall have at least one inlet using the medium Constituent-Electricity.	Link
An ElectronicDisplay shall have at least one inlet using the medium Electricity-Signal.	Link

12.27.1 s223:Monitor

An ElectronicDisplay designed primarily for the output of visual information supplied by a Computer.

12.27.2 s223:Television

An ElectronicDisplay that is designed primarily for the output of visual information supplied by a media broadcaster, and that typically has an integral tuner that is capable of selecting a single channel for display from the available input channel range.

12.28 s223:Elevator

A piece of Equipment that vertically transports people or freight between floors or levels of a building via a vertical shaft commonly referred to as a hoistway. The people or freight are typically situated on a platform, or in a container commonly referred to as a car, cab, cabin, cage, or carriage.

Related Constraints

Description	Link
An Elevator shall have at least one inlet using the medium Constituent-Electricity.	Link

12.29 s223:Escalator

A piece of Equipment that vertically transports people between floors or levels of a building via a moving staircase.

Related Constraints

Description	Link
An Escalator shall have at least one inlet using the medium Constituent-Electricity.	Link

12.30 s223:EthernetSwitch

A piece of Equipment that connects one or more instances of electrical equipment, such as Computers and Wi-Fi access points, to an Ethernet network so they can communicate with each other and, optionally, to the Internet.

Related Constraints

Description	Link
An EthernetSwitch shall have at least one inlet using the medium Constituent-Electricity.	Link
An EthernetSwitch shall have at least two bidirectional connection points using the medium Signal-WiredEthernet or Signal-FiberEthernet.	Link

12.31 s223:EthernetPort

A piece of Equipment that connects a single instance of electrical equipment, such as Computers and Wi-Fi access points, to an Ethernet network so it can communicate with other equipment and, optionally, with the Internet.

Related Constraints

Description	Link
An EthernetPort shall have at least one inlet using the medium Electricity-DC.	Link
An EthernetPort shall have at least two bidirectional connection points using the medium Signal-WiredEthernet or Signal-FiberEthernet.	Link

12.32 s223:Fan

A piece of Equipment that causes a gas (e.g., air) to flow.

Related Constraints

Description	Link
A Fan shall have at least one inlet using the medium Fluid-Air.	Link
A Fan shall have at least one outlet using the medium Fluid-Air.	Link

Related Inference Rules

Description	Link
If an instance of s223:Fan matches the constraints defined by g36:Fan, it will be declared as an instance of that class.	Link
If an instance of s223:Fan matches the constraints defined by g36:FanWithVFD, it will be declared as an instance of that class.	Link

12.33 s223:FanCoilUnit

A piece of Equipment consisting of a Coil and a Fan that regulates the temperature of one or more spaces.

Related Constraints

Description	Link
A FanCoilUnit shall at least have the role Role-Cooling or Role-Heating.	Link
A FanCoilUnit shall contain at least one Coil.	Link
A FanCoilUnit shall contain at least one Fan.	Link
A FanCoilUnit shall have at least one inlet using the medium Fluid-Air.	Link
A FanCoilUnit shall have at least one outlet using the medium Fluid-Air.	Link

12.34 s223:FiberEthernetOutlet

A piece of Equipment that contains one or more receptacles for connecting electrical equipment to a fiber Ethernet communication network, typically via a fiber Ethernet cable.

Related Constraints

Description	Link
A FiberEthernetOutlet shall have at least one outlet using the medium Signal-FiberEthernet.	Link
A FiberEthernetOutlet shall have exactly one inlet using the medium Signal-FiberEthernet.	Link

12.35 s223:Filter

A piece of Equipment that removes contaminants from gases or liquids. See Clause 10.11.1 for more details on validating compatible mediums upstream and downstream of a Filter.

Related Constraints

Description	Link
A Filter shall have at least one inlet.	Link
A Filter shall have at least one outlet.	Link
Incompatible Medium. Case 1: Associated ConnectionPoints with two pure mediums.	Link
Incompatible Medium. Case 2: Associated ConnectionPoints, one with a pure medium and one with a medium having constituents..	Link
Incompatible Medium. Case 3: Associated ConnectionPoints with mediums having constituents.	Link

12.36 s223:FlushToilet

A piece of Equipment that collects human waste (i.e., urine and/or feces, and sometimes toilet paper) in a chamber containing water, and contains an integral manual or automatic actuator that triggers the release of an additional volume of water that flushes everything from the chamber into a drainage system that typically carries the mixture to a sewer system or septic tank.

Related Constraints

Description	Link
A FlushToilet shall have at least one inlet using the medium Fluid-Water.	Link
A FlushToilet shall have at least one outlet using the medium Fluid-Water.	Link

12.37 s223:Freezer

A piece of Equipment that maintains an internal temperature below the freezing point of water.

Related Constraints

Description	Link
A Freezer shall have at least one inlet using the medium Constituent-Electricity.	Link

12.38 s223:FumeHood

A piece of Equipment that is typically mounted over a work area (e.g., a space, table, or shelf) and conducts unwanted gases away from the area.

Related Constraints

Description	Link
A FumeHood shall have at least one inlet using the medium Fluid-Air.	Link
A FumeHood shall have at least one outlet using the medium Fluid-Air.	Link

12.39 s223:Furnace

A piece of Equipment that converts fuel or electrical energy into heat.

Related Constraints

Description	Link
A Furnace shall have at least one inlet using the medium Fluid-Air.	Link
A Furnace shall have at least one outlet using the medium Fluid-Air.	Link

12.40 s223:Generator

A piece of Equipment that converts non-electric energy into electric energy.

Related Constraints

Description	Link
A Generator shall have at least one outlet using the medium Constituent-Electricity.	Link

12.41 s223:HeatPump

A piece of Equipment that heats or cools spaces by transferring thermal energy from one thermal environment to another using a reversible refrigeration cycle.

12.41.1 s223:AirToAirHeatPump

A HeatPump that transfers thermal energy between two bodies of air.

Related Constraints

Description	Link
An AirToAirHeatPump shall have at least two inlets using the medium Fluid-Air.	Link
An AirToAirHeatPump shall have at least two outlets using the medium Fluid-Air.	Link

12.41.2 s223:GroundToAirHeatPump

A HeatPump that transfers thermal energy between air and the ground.

Related Constraints

Description	Link
A GroundToAirHeatPump shall have at least one bidirectional connection point using the medium Medium-ThermalContact.	Link
A GroundToAirHeatPump shall have at least one inlet using the medium Fluid-Air.	Link
A GroundToAirHeatPump shall have at least one outlet using the medium Fluid-Air.	Link

12.41.3 s223:WaterToAirHeatPump

A HeatPump that transfers thermal energy between air and a body of water.

Related Constraints

Description	Link
A WaterToAirHeatPump shall have at least one inlet using the medium Fluid-Air.	Link
A WaterToAirHeatPump shall have at least one inlet using the medium Fluid-Water.	Link
A WaterToAirHeatPump shall have at least one outlet using the medium Fluid-Air.	Link
A WaterToAirHeatPump shall have at least one outlet using the medium Fluid-Water.	Link

12.41.4 s223:WaterToWaterHeatPump

A HeatPump that transfers thermal energy between two flows of water.

Related Constraints

Description	Link
A WaterToWaterHeatPump shall have at least two inlets using the medium Fluid-Water.	Link
A WaterToWaterHeatPump shall have at least two outlets using the medium Fluid-Water.	Link

12.42 s223:Humidifier

A piece of equipment that adds moisture to a gas (e.g., air).

12.43 s223:Humidistat

A piece of equipment that measures the relative humidity of the air and then uses this information to automatically adjust the amount of moisture in air.

12.44 s223:HydronicHeatExchanger

A piece of equipment that transfers heat from one liquid stream to another while keeping the two media separate.

Related Constraints

Description	Link
A HydronicHeatExchanger shall have at least two inlets using the medium Mix-Fluid, each paired with an outlet.	Link
A HydronicHeatExchanger shall have at least two outlets using the medium Mix-Fluid, each paired with an inlet.	Link
A HydronicHeatExchanger shall have no bidirectional connection points.	Link
A HydronicHeatExchanger shall have no connection points using the medium Fluid-Air.	Link

Related Inference Rules

Description	Link
Infer the hasRole s223:Role-HeatTransfer relation for every instance of the listed targetClass values.	Link

12.45 s223:IceMaker

A piece of Equipment that makes ice.

Related Constraints

Description	Link
An IceMaker shall have at least one inlet using the medium Constituent-Electricity.	Link
An IceMaker shall have at least one inlet using the medium Fluid-Water.	Link

12.46 s223:Luminaire

A piece of Equipment consisting of a light source(s) and ballast(s) or driver(s) (when applicable), together with the parts designed to distribute the light, to position and protect the light source(s), and to connect the light source(s) to the power supply. Also known as a light fixture.

Related Constraints

Description	Link
A Luminaire shall have at least one inlet using the medium Constituent-Electricity.	Link
A Luminaire shall have at least one outlet using the medium EM-Light.	Link

12.47 s223:MicrowaveOven

An ElectricOven that cooks food by exposing it to electromagnetic radiation in the microwave frequency range.

Related Constraints

Description	Link
A MicrowaveOven shall have at least one inlet using the medium Constituent-Electricity.	Link

12.48 s223:Motor

A piece of Equipment that converts electrical energy into mechanical energy.

Related Constraints

Description	Link
A Motor shall have at least one inlet using the medium Constituent-Electricity.	Link

12.49 s223:PhotovoltaicModule

A piece of equipment that converts sunlight into electricity.

Related Constraints

Description	Link
A PhotovoltaicModule shall have at least one inlet using the medium EM-Light.	Link
A PhotovoltaicModule shall have at least one outlet using the medium Constituent-Electricity.	Link

12.50 s223:PowerOverEthernetSwitch

A piece of Equipment that connects and is capable of powering one or more instances of electrical equipment, such as computers and Wi-Fi access points, as well as connect the equipment to an Ethernet network so they can communicate with each other and, optionally, to the Internet.

Related Constraints

Description	Link
A PowerOverEthernetSwitch shall have at least one bidirectional connection point using the medium PowerAndSignal-PoE.	Link
A PowerOverEthernetSwitch shall have at least one inlet using the medium Constituent-Electricity.	Link

12.51 s223:PowerOverEthernetPort

A piece of Equipment that connects and is capable of powering one instance of electrical equipment, such as computers and Wi-Fi access points, as well as connect it to an Ethernet network so it can communicate with other equipment and, optionally, with the Internet.

Related Constraints

Description	Link
A PowerOverEthernetPort shall have at least one bidirectional connection point using the medium PowerAndSignal-PoE.	Link
A PowerOverEthernetPort shall have at least one inlet using the medium Electricity-DC.	Link

12.52 s223:Pump

A piece of Equipment that imparts energy to a fluid, drawing a fluid into itself through an inlet port, and forcing the fluid out through an outlet port.

Related Constraints

Description	Link
A Pump shall have at least one inlet using the medium Fluid-Water, Fluid-Oil or Constituent-Refrigerant.	Link
A Pump shall have at least one outlet using the medium Fluid-Water, Fluid-Oil or Constituent-Refrigerant.	Link
The non-electrical ConnectionPoints of a Pump must have compatible media.	Link

12.53 s223:RadiantHeater

A piece of Equipment with heating or cooling surface that delivers 50% or more of its heat transfer by radiation. A RadiantHeater shall:

- Have the role Role-Heating.
- Have at least one outlet connection point using the medium Light-Infrared.
- Conform to exactly one of the following patterns:
 - **Pattern 1:**
 - Exactly one inlet connection point using the medium Constituent-Electricity or Fluid-NaturalGas.
 - **Pattern 2:**
 - Exactly one inlet connection point using the medium Fluid-Water.
 - Exactly one outlet connection point using the medium Fluid-Water.

Related Constraints

Description	Link
A RadiantHeater shall at least have the role Role-Heating.	Link
A RadiantHeater shall have at least one outlet using the medium Light-Infrared.	Link
Pattern 1: A radiant heater shall have at least one inlet using the medium Constituent-Electricity or Fluid-NaturalGas.	Link
Pattern 2: A radiant heater shall have an inlet using the medium Fluid-Water.	Link
Pattern 2: A radiant heater shall have an outlet using the medium Fluid-Water.	Link

Related Inference Rules

Description	Link
Infer the hasRole s223:Role-HeatTransfer relation for every instance of the listed targetClass values.	Link

12.54 s223:Radiator

A piece of Equipment that provides primarily convective heating to a room using electricity, steam, or water (e.g., electric baseboard heaters, heated floors, or traditional radiators).

Related Constraints

Description	Link
A Radiator shall at least have the role Role-Heating.	Link
A Radiator shall have at least one bidirectional connection point using the medium Fluid-Air.	Link
A Radiator shall have at least one inlet using the medium Electricity or inlet and outlet of Water.	Link

Related Inference Rules

Description	Link
Infer the hasRole s223:Role-HeatTransfer relation for every instance of the listed targetClass values.	Link

12.55 s223:Refrigerator

A piece of Equipment that maintains an internal temperature below the surrounding ambient temperature but above the freezing point of water.

Related Constraints

Description	Link
A Refrigerator shall have at least one inlet using the medium Constituent-Electricity.	Link

12.56 s223:RFOutlet

A piece of Equipment that contains one or more receptacles for connecting electrical equipment to a radio frequency (RF) communication network, via, for example, a coaxial cable.

Related Constraints

Description	Link
A RFOutlet shall have at least one outlet using the medium RF-Signal.	Link
A RFOutlet shall have exactly one inlet using the medium RF-Signal.	Link

12.57 s223:Sink

A piece of Equipment for manually washing hands, dishes, or other items that receives as an input hot or cold water dispensed from one or two Faucets, and is designed to hold a specific volume of water and release the held water through a Drain.

Related Constraints

Description	Link
A Sink shall have at least one inlet using the medium Fluid-Water.	Link
A Sink shall have at least one outlet using the medium Fluid-Water.	Link

12.58 s223:SolarThermalCollector

A piece of Equipment that converts sunlight into thermal energy.

Related Constraints

Description	Link
A SolarThermalCollector shall have at least one inlet using the medium EM-Light.	Link
A SolarThermalCollector shall have at least one outlet using the medium Fluid-Water.	Link

12.59 s223:SteamInjector

A piece of Equipment for increasing the humidity of an air stream by injecting steam into the air stream.

Related Constraints

Description	Link
A SteamInjector shall have at least one inlet using the medium Fluid-Air.	Link
A SteamInjector shall have at least one inlet using the medium Water-Steam.	Link
A SteamInjector shall have at least one outlet using the medium Fluid-Air.	Link

12.60 s223:TerminalUnit

A piece of Equipment that modulates the volume of air delivered to a space.

Related Constraints

Description	Link
A TerminalUnit shall have at least one inlet using the medium Fluid-Air.	Link
A TerminalUnit shall have at least one outlet using the medium Fluid-Air.	Link

12.60.1 s223:DualDuctTerminal

A TerminalUnit that mixes two independent sources of primary air.

Related Constraints

Description	Link
A <code>DualDuctTerminal</code> shall have at least two inlets using the medium <code>Fluid-Air</code> .	Link

Related Inference Rules

Description	Link
If an instance of <code>s223:DualDuctTerminal</code> matches the constraints defined by <code>g36:DualDuctTerminalWithDischargeSensor</code> , it will be declared as an instance of that class.	Link
If an instance of <code>s223:DualDuctTerminal</code> matches the constraints defined by <code>g36:DualDuctTerminalWithInletSensors</code> , it will be declared as an instance of that class.	Link

12.60.2 s223:FanPoweredTerminal

A `TerminalUnit` that contains a fan, and optionally has supplemental heating or cooling. Airflow may pass through or be parallel to the fan.

Related Constraints

Description	Link
A <code>FanPoweredTerminal</code> shall contain at least one <code>Fan</code> .	Link

Related Inference Rules

Description	Link
If an instance of <code>s223:FanPoweredTerminal</code> matches the constraints defined by <code>g36:FanPoweredTerminal</code> , it will be declared as an instance of that class.	Link

12.60.3 s223:SingleDuctTerminal

A `TerminalUnit` unit that has one ducted air inlet and a damper for regulating the flow of air.

Related Constraints

Description	Link
A <code>SingleDuctTerminal</code> shall contain at least one <code>Damper</code> .	Link

Related Inference Rules

Description	Link
If an instance of <code>s223:SingleDuctTerminal</code> matches the constraints defined by <code>g36:VAVTerminalCoolingOnly</code> , it will be declared as an instance of that class.	Link

Description	Link
If an instance of s223:SingleDuctTerminal matches the constraints defined by g36:VAVTerminalWithReheat, it will be declared as an instance of that class.	Link

12.61 s223:ThermalEnergyStorageUnit

A device that stores thermal energy.

Related Constraints

Description	Link
A ThermalEnergyStorageUnit shall be associated with at least two connection points using the relation hasConnectionPoint.	Link

12.62 s223:Thermostat

A piece of Equipment that maintains temperature at a fixed or adjustable setpoint.

12.63 s223:Turbine

A piece of Equipment that converts mechanical energy into electric energy.

Related Constraints

Description	Link
A Turbine shall have at least one outlet using the medium Constituent-Electricity.	Link

12.64 s223:USBOutlet

A piece of Equipment that contains one or more receptacles for connecting electrical equipment to a USB communication network, typically via a USB cable.

Related Constraints

Description	Link
A USBOutlet shall have at least one outlet using the medium Signal-USB.	Link
A USBOutlet shall have exactly one inlet using the medium Signal-USB.	Link

12.65 s223:Valve

A piece of Equipment that can be adjusted to allow, regulate, or stop the flow of fluid in a pipe or a duct.

Related Constraints

Description	Link
A Valve shall have at least one inlet and one outlet or two bidirectional connection points.	Link

Related Inference Rules

Description	Link
If an instance of s223:Valve matches the constraints defined by g36:ChilledWaterValve, it will be declared as an instance of that class.	Link
If an instance of s223:Valve matches the constraints defined by g36:HotWaterValve, it will be declared as an instance of that class.	Link

12.65.1 s223:Drain

A Valve that allows, regulates, or stops the flow of water from a Sink, Shower, Bathtub, or other plumbing service equipment into a plumbing drainage system that typically carries the mixture to a sewer system or septic tank.

Related Constraints

Description	Link
A Drain shall have at least one inlet using the medium Fluid-Water.	Link
A Drain shall have at least one outlet using the medium Fluid-Water.	Link

12.65.2 s223:Faucet

A Valve that allows, regulates, or stops the flow of hot or cold water from a plumbing supply system into a Sink, Shower, Bathtub, or other plumbing service equipment.

Related Constraints

Description	Link
A Faucet shall have at least one inlet using the medium Fluid-Water.	Link
A Faucet shall have at least one outlet using the medium Fluid-Water.	Link

12.65.3 s223:ThreeWayValve

A Valve that can divert a fluid in one of three directions.

Related Constraints

Description	Link
A ThreeWayValve shall be associated with at least three connection points using the relation hasConnectionPoint.	Link

12.65.4 s223:TwoWayValve

A Valve that can divert a fluid in one of two directions.

Related Constraints

Description	Link
A TwoWayValve shall have at least one inlet.	Link
A TwoWayValve shall have at least one outlet.	Link

12.66 s223:VariableFrequencyDrive

A piece of Equipment that varies its output frequency to vary the rotating speed and torque of a motor, given a fixed input frequency. Used with fans or pumps to vary the flow in the system as a function of a maintained pressure.

Related Constraints

Description	Link
A VariableFrequencyDrive shall be associated with zero or more pieces of Equipment using the relation connectedTo.	Link
A VariableFrequencyDrive shall have at least one inlet using the medium Constituent-Electricity.	Link
A VariableFrequencyDrive shall have at least one outlet using the medium Constituent-Electricity.	Link

12.67 s223:WaterOutlet

A piece of Equipment that contains one or more pipe fittings for connecting plumbing equipment (e.g., Faucet) to a plumbing system.

Related Constraints

Description	Link
A WaterOutlet shall have at least one outlet using the medium Fluid-Water.	Link
A WaterOutlet shall have exactly one inlet using the medium Fluid-Water.	Link

12.68 s223:Window

A piece of Equipment that provides a pathway for EM-Light or Fluid-Air (or both) to flow from a room to another room or the building exterior through a vertical or nearly vertical area of the room envelope.

Related Constraints

Description	Link
A Window shall have at least one inlet using the medium EM-Light or Fluid-Air.	Link
A Window shall have at least one outlet using the medium EM-Light or Fluid-Air.	Link

12.69 s223:WindowShade

A piece of Equipment that can be adjusted to allow, regulate, or stop the flow of light through a Window.

12.70 s223:WiredEthernetOutlet

A piece of Equipment that contains one or more receptacles for connecting electrical equipment to a wired Ethernet communication network, typically via a wired Ethernet cable.

Related Constraints

Description	Link
A WiredEthernetOutlet shall have at least one outlet using the medium Signal-WiredEthernet.	Link
A WiredEthernetOutlet shall have exactly one inlet using the medium Signal-WiredEthernet.	Link

Annex A - RDF REPRESENTATION OF THIS STANDARD (NORMATIVE)

The text of this standard was generated from an RDF Model. An electronic repository containing a normative Turtle representation of the model can be found at <https://data.ashrae.org/bacnet/223p/223p.ttl>. A user may wish to use electronic tools to browse and study the details of the standard, use the equipment types defined in the standard to build a building-specific information model, apply the SHACL constraints to test a building specific model for conformance to the standard, or other uses.

Annex B - ASHRAE GUIDELINE 36 EXTENSION (INFORMATIVE)

This extension uses the concepts defined in the 223 standard to model the ASHRAE Guideline 36 data requirements for air-side equipment, defined in Section 4 of ASHRAE Guideline 36-2024. These requirements are modeled as classes that use SHACL constraints to define how the equipment should be modeled in 223, focusing on the data points needed for Guideline 36 control sequences. These classes can be used to ensure that a model has the metadata necessary to support Guideline 36 sequences. They can be used to validate existing models against the requirements of Guideline 36 or to support modeling of compliant systems. They can also be used to create templates or support tooling that creates models to match the defined constraints. We have also included SHACL inference rules to infer labels for equipment within an existing 223 model, where modeling of the equipment satisfies the constraints defined for the Guideline 36 classes. This can support querying and semantic interoperability between models created with and without use of this extension. Additionally, this section includes example models of the systems presented in the Informative Appendix A of Guideline 36. This content is intended to serve as an example of how the 223 standard can be extended to create higher level classes specific to an application, that can be useful for both validation and inference. It is also intended to provide examples of how equipment can be modeled using 223.

Annex B.1 Model Components

This section describes the classes representing common components used in this extension. These components are not directly defined within Section 4 of Guideline 36, but are shared between the many systems described. For example, g36:VAVTerminalCoolingOnly (see Clause Annex B.2.1), g36:VAVTerminalWithReheat (see Clause Annex B.3.1), g36:FanPoweredTerminal (see Clause Annex B.4.1), g36:DualDuctTerminalWithInletSensors (see Clause Annex B.5.1), and g36:DualDuctTerminalWithDischargeSensor (see Clause Annex B.6.1) all share requirements for what properties a Zone must have. The Guideline 36 classes defined in subsequent sections are composed of the following components.

Annex B.1.1 g36:Damper

A damper with an analog or two binary position command properties.

Related Constraints

Description	Link
A damper shall have at least one analog damper command property or at least two binary damper command properties using the relation hasProperty.	Link

Annex B.1.2 g36:DamperAnnotation

Related Inference Rules

Description	Link
If an instance of s223:Damper matches the constraints defined by g36:Damper, it will be declared as an instance of that class.	Link

Annex B.1.3 g36:TwoPositionDamper

A damper that can take two positions: fully open and fully closed.

Related Constraints

Description	Link
A Two Position Damper shall have at least one open-and-close damper command property using the relation hasProperty.	Link

Annex B.1.4 g36:TwoPositionDamperAnnotation

Related Inference Rules

Description	Link
If an instance of s223:Damper matches the constraints defined by g36:TwoPositionDamper, it will be declared as an instance of that class.	Link

Annex B.1.5 g36:HotWaterCoil

A hot water coil connected to a control valve.

Related Constraints

Description	Link
The HotWaterCoil shall be connected to a HotWaterValve using the relation connectedTo.	Link

Annex B.1.6 g36:HotWaterCoilAnnotation

Related Inference Rules

Description	Link
If an instance of s223:HeatingCoil matches the constraints defined by g36:HotWaterCoil, it will be declared as an instance of that class.	Link

Annex B.1.7 g36:ElectricHeatingCoil

An electrical heating element with an analog heating command.

Related Constraints

Description	Link
An electric heating coil shall have at least one analog heating command property using a relation hasProperty.	Link

Annex B.1.8 g36:ElectricHeatingCoilAnnotation

Related Inference Rules

Description	Link
If an instance of s223:ElectricResistanceElement matches the constraints defined by g36:ElectricHeatingCoil, it will be declared as an instance of that class.	Link

Annex B.1.9 g36:HotWaterValve

A valve that controls the flow of hot water through a hot water coil.

Related Constraints

Description	Link
A HotWaterValve shall have at least one analog valve command property or at least two binary valve command properties using the relation hasProperty.	Link

Annex B.1.10 g36:HotWaterValveAnnotation

Related Inference Rules

Description	Link
If an instance of s223:Valve matches the constraints defined by g36:HotWaterValve, it will be declared as an instance of that class.	Link

Annex B.1.11 g36:ChilledWaterCoil

A cooling coil with a connected chilled water valve.

Related Constraints

Description	Link
The ChilledWaterCoil shall be connected to a ChilledWaterValve using the relation connectedTo.	Link

Annex B.1.12 g36:ChilledWaterCoilAnnotation

Related Inference Rules

Description	Link
If an instance of s223:CoolingCoil matches the constraints defined by g36:ChilledWaterCoil, it will be declared as an instance of that class.	Link

Annex B.1.13 g36:ChilledWaterValve

A valve that controls the flow of chilled water through a chilled water coil.

Related Constraints

Description	Link
A ChilledWaterValve shall have at least one analog valve command property or at least two binary valve command properties using the relation hasProperty.	Link

Annex B.1.14 g36:ChilledWaterValveAnnotation

Related Inference Rules

Description	Link
If an instance of s223:Valve matches the constraints defined by g36:ChilledWaterValve, it will be declared as an instance of that class.	Link

Annex B.1.15 g36:Zone

A thermal zone with the points required for Guideline 36 control sequences. It is a collection of s223:DomainSpace instances.

Related Constraints

Description	Link
A Zone shall have a zone temperature setpoint adjustment property using the relation hasProperty, if applicable.	Link
A Zone shall have at least a zone CO2 concentration property using the relation hasProperty, if applicable control is used.	Link
A Zone shall have at least one Domain-HVAC using the relation hasDomain.	Link
A Zone shall have at least one binary zone occupancy property using the relation hasProperty	Link
A Zone shall have at least one window switch on-off property using the relation hasProperty.	Link

Annex B.1.16 g36:ZoneAnnotation

Related Inference Rules

Description	Link
If an instance of Zone matches the constraints defined by g36:Zone, it will be declared as an instance of that class.	Link

Annex B.1.17 g36:ZoneGroup

A ZoneGroup is a grouping of zones that may be scheduled together. Zone groupings must be assigned based on rules in Clause 3.1.3 of Guideline 36.

Related Constraints

Description	Link
A ZoneGroup shall contain at least one Zone using the relation contains.	Link
A ZoneGroup shall have the Domain HVAC using the relation hasDomain.	Link

Annex B.1.18 g36:ZoneGroupAnnotation

Related Inference Rules

Description	Link
If an instance of Zone matches the constraints defined by g36:ZoneGroup, it will be declared as an instance of that class.	Link

Annex B.1.19 g36:Fan

A fan with a start/stop command.

Related Constraints

Description	Link
A Fan shall have at least one Start/Stop command using the relation hasProperty.	Link

Annex B.1.20 g36:FanAnnotation

Related Inference Rules

Description	Link
If an instance of s223:Fan matches the constraints defined by g36:Fan, it will be declared as an instance of that class.	Link

Annex B.1.21 g36:FanWithVFD

A fan controlled by a VFD.

Related Constraints

Description	Link
A fan with VFD shall have at least one fan speed command using the relation hasProperty.	Link

Annex B.1.22 g36:FanWithVFDAnnotation

Related Inference Rules

Description	Link
If an instance of s223:Fan matches the constraints defined by g36:FanWithVFD, it will be declared as an instance of that class.	Link

Annex B.2 VAV Terminal Unit - Cooling Only

This section describes the VAV Terminal Unit - Cooling Only class defined by this extension. Constraints are based on Guideline 36 Section 4.1.

Annex B.2.1 g36:VAVTerminalCoolingOnly

An air-terminal unit assembly having one ducted air inlet and a damper for regulating the airflow rate.

Related Constraints

Description	Link
The VAVTerminalCoolingOnly OutletConnectionPoint shall have at least one discharge airflow property using the relation hasProperty.	Link
The VAVTerminalCoolingOnly connects to Domain Space in a g36:Zone	Link
The VAVTerminalCoolingOnly shall contain exactly one Damper using the relation contains.	Link

Annex B.2.2 g36:VAVTerminalCoolingOnlyAnnotation

Related Inference Rules

Description	Link
If an instance of s223:SingleDuctTerminal matches the constraints defined by g36:VAVTerminalCoolingOnly, it will be declared as an instance of that class.	Link

Annex B.2.3 Example VAV Terminal Unit - Cooling Only

VAV Terminal Unit - Cooling Only based on Figure A-1. [Link to Model](#)

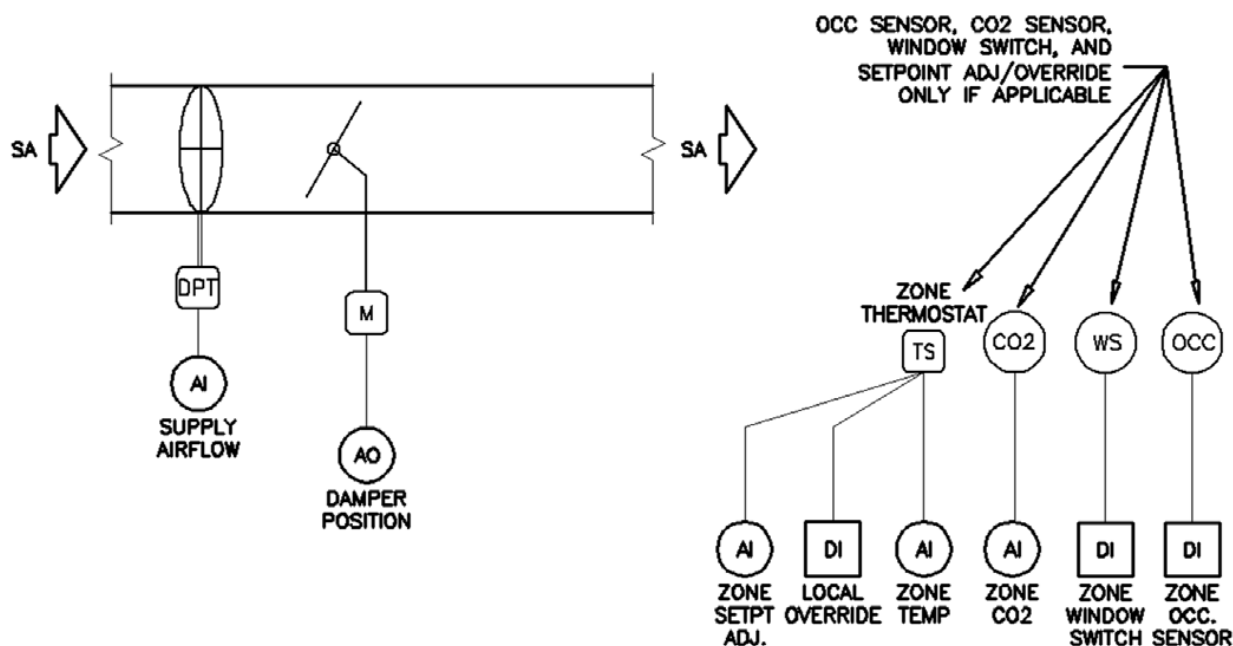

Figure Annex B-1. Guideline 36 Figure A-1.

Annex B.3 VAV Terminal Unit with Reheat

This section describes the VAV Terminal Unit with Reheat described in Section 4.2 and Appendix A, Figure A-2 (ASHRAE Guideline 36-2024)

Annex B.3.1 g36:VAVTerminalWithReheat

An air-terminal unit assembly having one ducted air inlet, a damper, and a reheat coil for regulating the airflow rate and discharge air temperature.

Related Constraints

Description	Link
The VAVTerminalWithReheat OutletConnectionPoint shall have at least one discharge air temperature property using the relation hasProperty.	Link
The VAVTerminalWithReheat connects to Domain Space in a g36:Zone	Link
The VAVTerminalWithReheat shall contain at least one hot water coil or at least one electric heating coil for heating using the relation contains.	Link

Annex B.3.2 g36:VAVTerminalWithReheatAnnotation

Related Inference Rules

Description	Link
If an instance of s223:SingleDuctTerminal matches the constraints defined by g36:VAVTerminalWithReheat, it will be declared as an instance of that class.	Link

Annex B.3.3 Example VAV Terminal Unit With Reheat

VAV Terminal Unit With Reheat based on Figure A-2. [Link to Model](#)

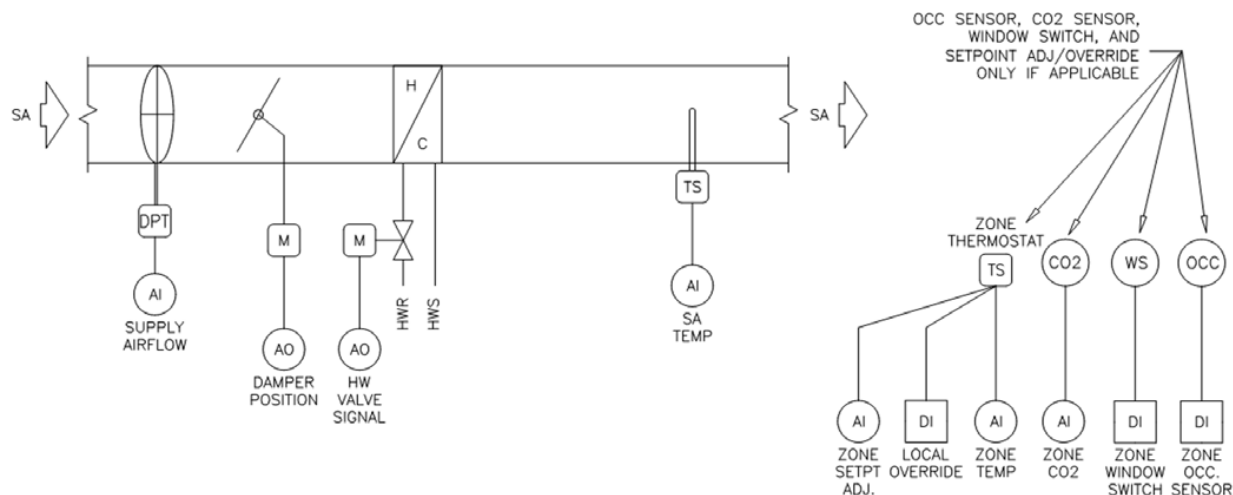

Figure Annex B-2. Guideline 36 Figure A-2.

Annex B.4 Fan Powered Terminal Unit

This section describes the classes and example model of the Fan Powered Terminal Unit (Series or Parallel, Constant or Variable Speed Fan) described in Section 4.3.

Annex B.4.1 g36:FanPoweredTerminal

An air terminal containing a fan. Airflow may pass through or be parallel to the fan. These units may also have supplemental heating or cooling.

Related Constraints

Description	Link
A FanPoweredTerminal shall contain at least one hot water coil or at least one electric heating coil for heating using the relation contains.	Link
A FanPoweredTerminal shall have exactly one Damper using the relation contains.	Link
A FanPoweredTerminal shall have exactly one Fan or FanWithVFD using the relation contains.	Link
The FanPoweredTerminal InletConnectionPoint shall have at least one supply airflow property using the relation hasProperty.	Link
The FanPoweredTerminal OutletConnectionPoint shall have at least one discharge air temperature property using the relation hasProperty.	Link

Annex B.4.2 g36:FanPoweredTerminalAnnotation

Related Inference Rules

Description	Link
If an instance of s223:FanPoweredTerminal matches the constraints defined by g36:FanPoweredTerminal, it will be declared as an instance of that class.	Link

Annex B.4.3 Example Fan Powered Terminal Unit

Example Fan Powered Terminal Unit based on Figure A-3. [Link to Model](#)

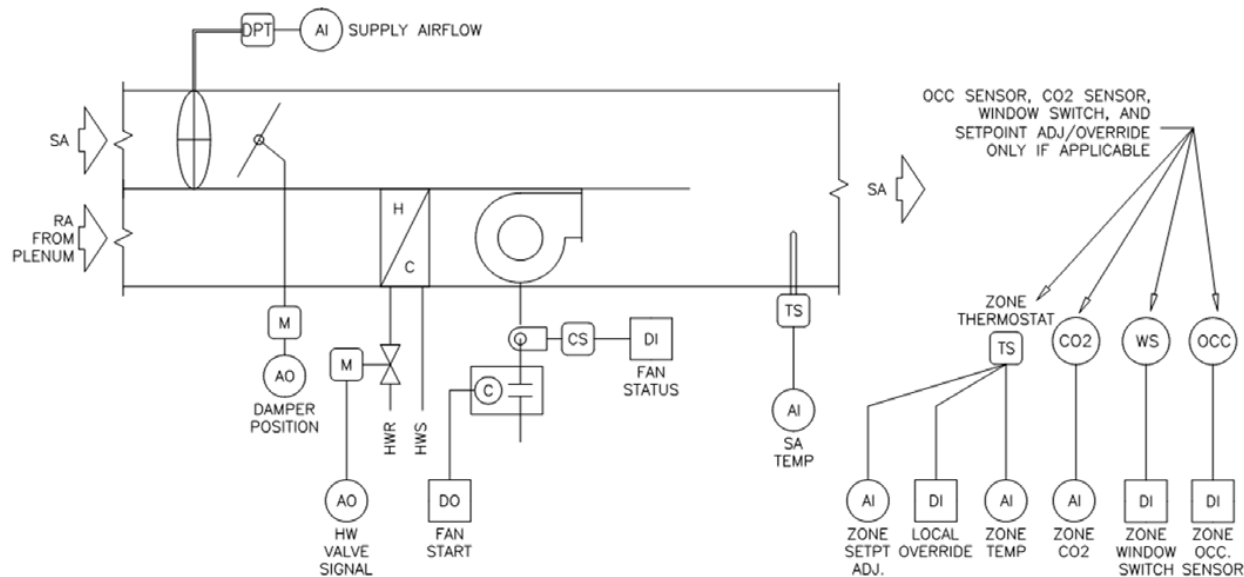

Figure Annex B-3. Guideline 36 Figure A-3.

Annex B.4.4 Example Parallel Fan Powered Terminal Unit

Example Parallel Fan Powered Terminal Unit based on Figure A-4. [Link to Model](#)

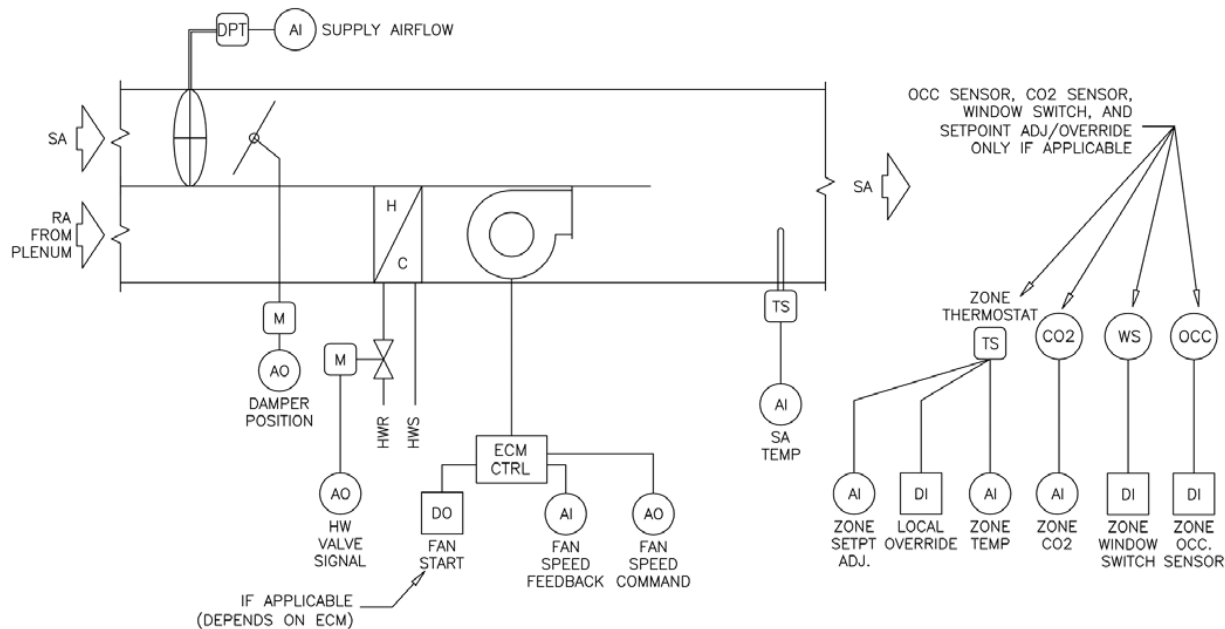

Figure Annex B-4. Guideline 36 Figure A-4.

Annex B.5 Dual Duct Terminal Unit with Inlet Sensors

This section describes the classes and example model of the Dual Duct Terminal Unit with Inlet at Sensors described in Section 4.4 and Appendix A, Figure A-7 (ASHRAE Guideline 36-2024).

Annex B.5.1 g36: DualDuctTerminalWithInletSensors

A dual duct air terminal mixes two independent sources of primary air. This terminal uses two inlet sensors.

Related Constraints

Description	Link
DualDuctTerminalWithInletSensors shall contain 1 damper that has the Role Cooling using the relation contains.	Link
DualDuctTerminalWithInletSensors shall contain 1 damper that has the Role Heating using the relation contains.	Link
DualDuctTerminalWithInletSensors shall contain 2 dampers using the relation contains	Link
The DualDuctTerminalWithInletSensors InletConnectionPoint shall have at least one cooling supply airflow property using the relation hasProperty.	Link
The DualDuctTerminalWithInletSensors InletConnectionPoint shall have at least one heating supply airflow property using the relation hasProperty.	Link

Annex B.5.2 g36:DualDuctTerminalWithInletSensorsAnnotation

Related Inference Rules

Description	Link
If an instance of s223:DualDuctTerminal matches the constraints defined by g36:DualDuctTerminalWithInletSensors, it will be declared as an instance of that class.	Link

Annex B.5.3 Example Dual Duct Terminal Unit With Inlet Sensors

Dual Duct Terminal Unit based on Figure A-7. [Link to Model](#)

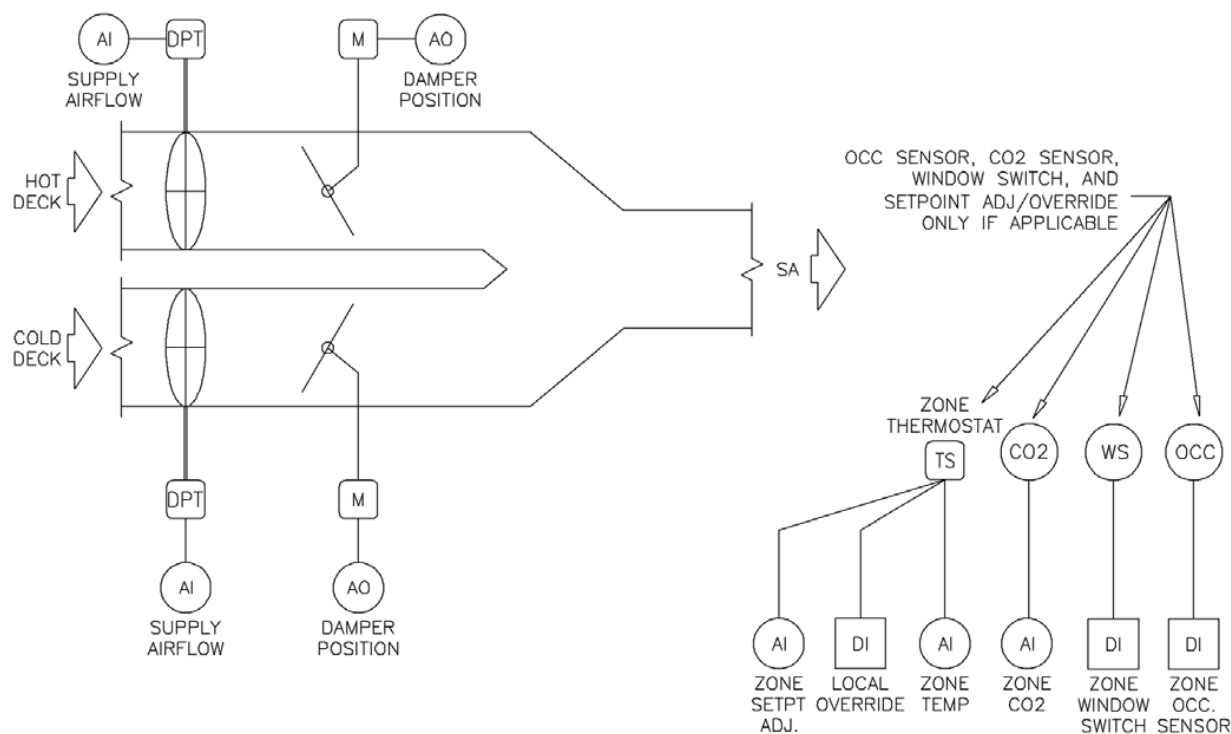

Figure Annex B-5. Guideline 36 Figure A-7.

Annex B.6 Dual Duct Terminal Unit with Discharge Sensor

This section describes the classes and example model of the Dual Duct Terminal Unit with Discharge Sensor described in Section 4.5 and Appendix A, Figure A-8 (ASHRAE Guideline 36-2024)

Annex B.6.1 g36:DualDuctTerminalWithDischargeSensor

A dual duct air terminal mixes two independent sources of primary air. This terminal uses one discharge sensor.

Related Constraints

Description	Link
In the DualDuctTerminalWithDischargeSensor, one Damper has Role Cooling using the relation hasRole.	Link
In the DualDuctTerminalWithDischargeSensor, one Damper has Role Heating using the relation hasRole.	Link
The DualDuctTerminalWithDischargeSensor OutletConnectionPoint shall have at least one discharge airflow property using the relation hasProperty.	Link
The DualDuctTerminalWithDischargeSensor shall contain 2 dampers using the relation contains.	Link

Annex B.6.2 g36: DualDuctTerminalWithDischargeSensor Annotation

Related Inference Rules

Description	Link
If an instance of s223: DualDuctTerminal matches the constraints defined by g36: DualDuctTerminalWithDischargeSensor, it will be declared as an instance of that class.	Link

Annex B.6.3 Example Dual Duct Terminal Unit With Discharge Sensors

Dual Duct Terminal Unit With Discharge Sensors based on Figure A-8. [Link to Model](#)

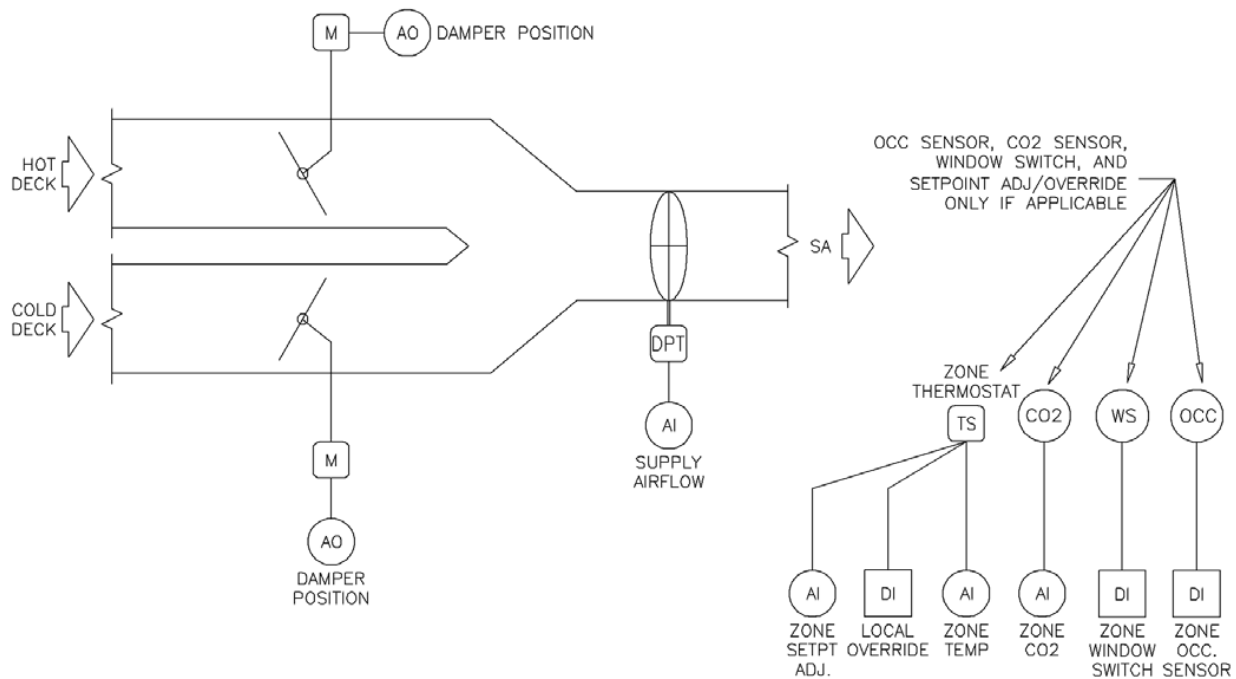

Figure Annex B-6. Guideline 36 Figure A-8.

Annex B.7 Multiple Zone VAV Air Handling Unit

This section describes the classes and example model of the Multiple Zone VAV Air Handling Unit described in Section 4.6 and Appendix A, Figures A-9 and A-10 (ASHRAE Guideline 36-2024)

Annex B.7.1 doc:MultipleZoneVAVAirHandlingUnitExample

Annex B.7.2 g36:MultipleZoneVAVAirHandlingUnit

An assembly consisting of sections containing a fan or fans and other necessary equipment to perform one or more of the following functions: circulating, filtration, heating, cooling, heat recovery, humidifying, dehumidifying, and mixing of air. It is usually connected to an air-distribution system. This air handling unit serves multiple zones.

Related Constraints

Description	Link
One MultipleZoneVAVAirHandlingUnit InletConnectionPoint shall have at least one outdoor air temperature property using the relation hasProperty.	Link
One MultipleZoneVAVAirHandlingUnit InletConnectionPoint shall have at least one return air temperature property using the relation hasProperty.	Link
One MultipleZoneVAVAirHandlingUnit OutletConnectionPoint shall have at least one supply air temperature property using the relation hasProperty.	Link
The MultipleZoneVAVAirHandlingUnit shall contain at least one ChilledWaterCoil for cooling using the relation contains.	Link
The MultipleZoneVAVAirHandlingUnit shall contain at least one HotWaterCoil or at least one ElectricHeatingCoil for heating using the relation contains.	Link
The MultipleZoneVAVAirHandlingUnit OutletConnectionPoint shall have at least one supply duct static pressure property using the relation hasProperty.	Link
The MultipleZoneVAVAirHandlingUnit shall contain at least one return air damper using the relation contains.	Link
The MultipleZoneVAVAirHandlingUnit shall contain at least one supply fan with a VFD that has the role Supply using the relation contains	Link

Annex B.7.3 g36:MultipleZoneVAVAirHandlingUnitAnnotation

Related Inference Rules

Description	Link
If an instance of s223:AirHandlingUnit matches the constraints defined by g36:MultipleZoneVAVAirHandlingUnit, it will be declared as an instance of that class.	Link

Annex B.7.4 g36:MultipleZoneVAVAirHandlingUnit-CommonDamper

For units with a common economizer/minimum OA damper, include the following points

Related Constraints

Description	Link
For units with a common economizer/minimum OA damper, MultipleZoneVAVAirHandlingUnit InletConnectionPoint must have at least one outdoor airflow property.	Link
For units with a common economizer/minimum OA damper, must have exactly one economizer/minimum outdoor air damper.	Link

Annex B.7.5 g36:MultipleZoneVAVAirHandlingUnit-CommonDamperAnnotation

Related Inference Rules

Description	Link
If an instance of s223:AirHandlingUnit matches the constraints defined by g36:MultipleZoneVAVAirHandlingUnit and has a common economizer/minimum outdoor air damper, it will be declared as an instance of this class.	Link

Annex B.7.6 g36:MultipleZoneVAVAirHandlingUnit-OADandAFMS

A unit with a separate minimum outdoor air damper and AFMS

Related Constraints

Description	Link
For units with a separate minimum outdoor air damper and AFMS, MultipleZoneVAVAirHandlingUnit must contain a modulating outdoor air damper with a minimum airflow property.	Link

Annex B.7.7 g36:MultipleZoneVAVAirHandlingUnit-OADandAFMSAnnotation

Related Inference Rules

Description	Link
If an instance of s223:AirHandlingUnit matches the constraints defined by g36:MultipleZoneVAVAirHandlingUnit-OADandAFMS, it will be declared as an instance of that class.	Link

Annex B.7.8 g36:MultipleZoneVAVAirHandlingUnit-OADandDP

A unit with a separate minimum outdoor air damper and DP sensor

Related Constraints

Description	Link
For units with a separate minimum outdoor air damper and DP sensor, MultipleZoneVAVAirHandlingUnit must contain a two-position outdoor air damper with a differential pressure property.	Link

Annex B.7.9 g36:MultipleZoneVAVAirHandlingUnit-OADandDPAnnotation

Related Inference Rules

Description	Link
If an instance of s223:AirHandlingUnit matches the constraints defined by g36:MultipleZoneVAVAirHandlingUnit-OADandDP, it will be declared as an instance of that class.	Link

Annex B.7.10 g36:MultipleZoneVAVAirHandlingUnit-WithReliefDamper

A unit with an actuated relief damper but no relief fan

Related Constraints

Description	Link
For units with actuated relief dampers but no relief fan, the MultipleZoneVAVAirHandlingUnit must be connectedTo at least one VAV, which connectedTo at least one HVAC DomainSpace, which is contained by at least one Zone, which has a building static pressure property.	Link
For units with actuated relief dampers but no relief fan, the MultipleZoneVAVAirHandlingUnit must contain a relief air damper with an analog damper command property.	Link

Annex B.7.11 g36:MultipleZoneVAVAirHandlingUnit-WithReliefDamperAnnotation

Related Inference Rules

Description	Link
If an instance of s223:AirHandlingUnit matches the constraints defined by g36:MultipleZoneVAVAirHandlingUnit and has a relief damper, it will be declared as an instance of this class.	Link

Annex B.7.12 g36:MultipleZoneVAVAirHandlingUnit-WithReliefFan

A unit with a relief fan

Related Constraints

Description	Link
For units with both a relief air damper and a relief fan, the MultipleZoneVAVAirHandlingUnit must have a relief air damper with a two-position damper command property.	Link
For units with both a relief air damper and a relief fan, the MultipleZoneVAVAirHandlingUnit must have a relief fan with a VFD.	Link

Annex B.7.13 g36:MultipleZoneVAVAirHandlingUnit-WithReturnFan

A unit with a return fan

Related Constraints

Description	Link
For units with a return fan, if airflow tracking logic is used, the OutletConnectionPoint of the return fan in the MultipleZoneVAVAirHandlingUnit must have a return airflow property.	Link
For units with a return fan, if airflow tracking logic is used, the OutletConnectionPoint of the supply fan in the MultipleZoneVAVAirHandlingUnit must have a supply airflow property.	Link
For units with a return fan, if direct building pressure logic is used, the MultipleZoneVAVAirHandlingUnit must be connectedTo at least one VAV, which connectedTo at least one HVAC DomainSpace, which is contained by at least one Zone, which has a building static pressure property.	Link
For units with a return fan, if direct building pressure logic is used, the OutletConnectionPoint of the return fan in the MultipleZoneVAVAirHandlingUnit must have a return fan discharge static pressure property.	Link
For units with a return fan, the MultipleZoneVAVAirHandlingUnit must contain an exhaust air damper.	Link
For units with a return fan, the MultipleZoneVAVAirHandlingUnit must indeed contain a return fan.	Link

Annex B.7.14 g36:SingleZoneVAVAirHandlingUnit-WithReliefDamper

A SingleZoneVAVAirHandlingUnit with a relief air damper and no relief fan

Related Constraints

Description	Link
the SingleZoneVAVAirHandlingUnit contains a relief air damper with a modulating actuator.	Link

Annex B.7.15 Example Multiple Zone VAV Air Handling Unit

Multiple Zone VAV Air Handling Unit based on Figure A-9. [Link to Model](#).

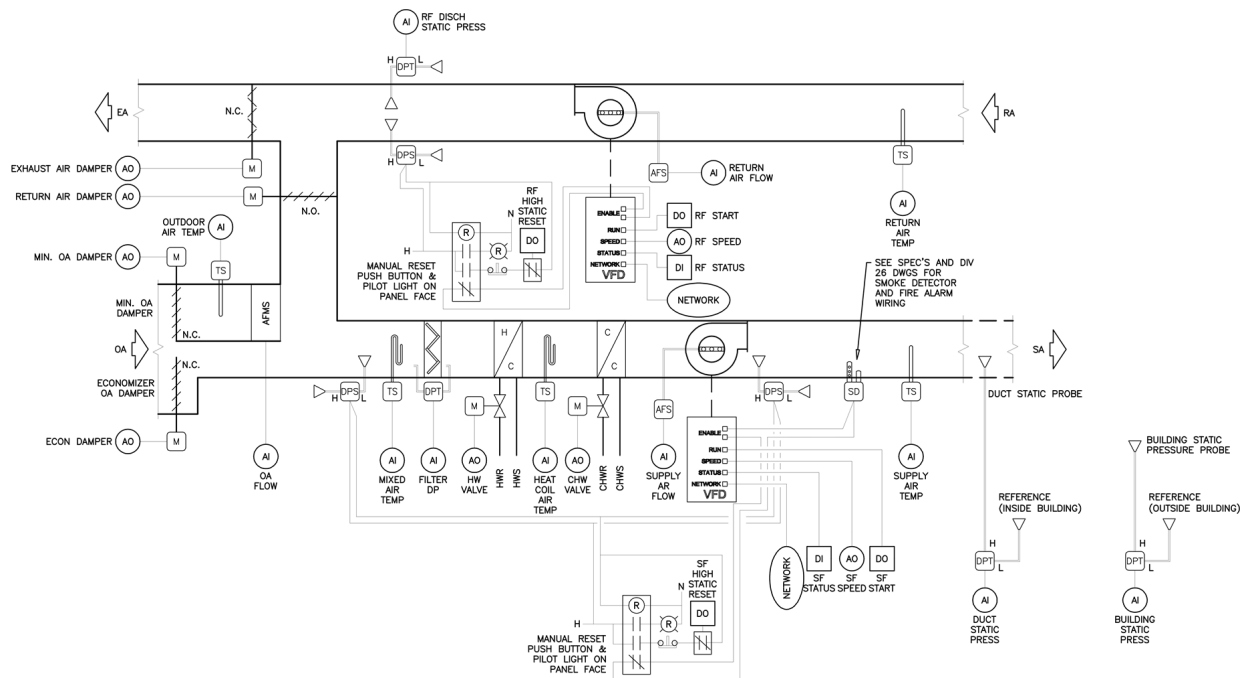

Figure Annex B-7. Guideline 36 Figure A-9.

Annex B.8 Dual Fan Dual Duct Air Handling Unit

This section describes the classes and example model of the Dual Fan Dual Duct Air Handling Unit described in Section 4.7 and Appendix A, Figure A-11 (ASHRAE Guideline 36-2024)

Annex B.8.1 g36:DualFanDualDuctAirHandlingUnit

DualFanDualDuctAirHandlingUnit

Related Constraints

Description	Link
A DualFanDualDuctAirHandlingUnit OutletConnectionPoint shall have at least one supply air temperature property using the relation hasProperty.	Link
A DualFanDualDuctAirHandlingUnit OutletConnectionPoint shall have at least one supply duct static pressure property using the relation hasProperty.	Link
The DualFanDualDuctAirHandlingUnit shall contain at least one HotWaterCoil or at least one ElectricHeatingCoil for heating using the relation contains.	Link
The DualFanDualDuctAirHandlingUnit shall contain at least one supply fan with a VFD that has the role Supply using the relation contains.	Link

Annex B.8.2 g36: DualFanDualDuctAirHandlingUnitAnnotation Related Inference Rules

Description	Link
If an instance of s223:AirHandlingUnit matches the constraints defined by g36: DualFanDualDuctAirHandlingUnit, it will be declared as an instance of that class.	Link

Annex B.8.3 Example Dual Fan Dual Duct Air Handling Unit.

Dual Fan Dual Duct Air Handling Unit based on Figure A-11. [Link to Model](#)

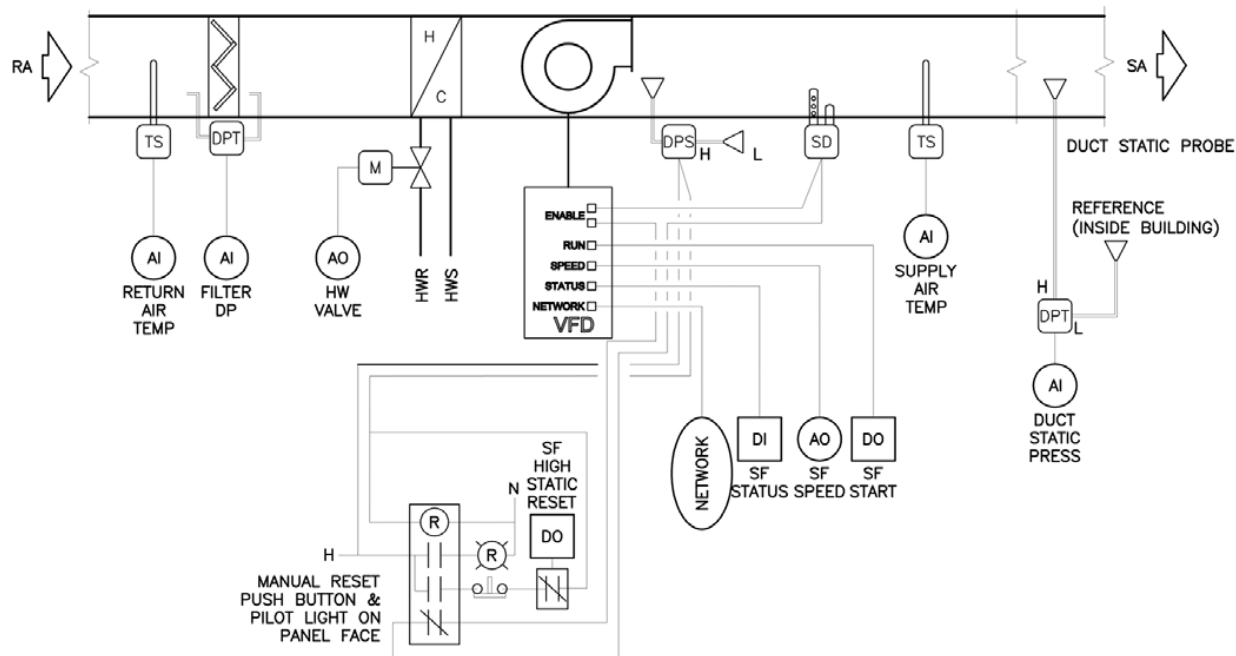

Figure Annex B-8. Guideline 36 Figure A-11.

Annex B.9 Single Zone VAV Air Handling Unit

This section describes the classes and example model of the Single Zone VAV Air Handling Unit described in Section 4.8 and Appendix A, Figure A-12 (ASHRAE Guideline 36-2024)

Annex B.9.1 g36: SingleZoneVAVAirHandlingUnit

An assembly consisting of sections containing a fan or fans and other necessary equipment to perform one or more of the following functions: circulating, filtration, heating, cooling, heat recovery, humidifying, dehumidifying, and mixing of air. It is usually connected to an air-distribution system. This air handling unit that serves one zone only.

Related Constraints

Description	Link
A SingleZoneVAVAirHandlingUnit OutletConnectionPoint shall have at least one supply air temperature property using the relation hasProperty.	Link
The SingleZoneVAVAirHandlingUnit shall contain at least one ChilledWaterCoil for cooling using the relation contains.	Link
The SingleZoneVAVAirHandlingUnit shall contain at least one HotWaterCoil or at least one ElectricHeatingCoil for heating using the relation contains.	Link
The SingleZoneVAVAirHandlingUnit shall contain at least one supply fan with a VFD that has the role Supply using the relation contains.	Link
The SingleZoneVAVAirHandlingUnit shall have at least one outdoor air damper using the relation contains.	Link
The SingleZoneVAVAirHandlingUnit shall have at least one return air damper using the relation contains.	Link

Annex B.9.2 g36:SingleZoneVAVAirHandlingUnitAnnotation

Related Inference Rules

Description	Link
If an instance of s223:AirHandlingUnit matches the constraints defined by g36:SingleZoneVAVAirHandlingUnit, it will be declared as an instance of that class.	Link

Annex B.9.3 g36:SingleZoneVAVAirHandlingUnit-NoReliefFan**Annex B.9.4 g36:SingleZoneVAVAirHandlingUnit-NoReliefFanAnnotation****Annex B.9.5 g36:SingleZoneVAVAirHandlingUnit-WithReliefFan**

A SingleZoneVAVAirHandlingUnit with a relief fan and relief dampers

Related Constraints

Description	Link
For the case where the SingleZoneVAVAirHandlingUnit has both a relief air damper and a relief fan, the SingleZoneVAVAirHandlingUnit must be connectedTo at least one VAV, which is connectedTo at least one HVAC DomainSpace or Zone, which has a building static pressure property.	Link
For the case where the SingleZoneVAVAirHandlingUnit has both a relief air damper and a relief fan, the SingleZoneVAVAirHandlingUnit must indeed have a relief air damper with a two-position damper command property.	Link
For the case where the SingleZoneVAVAirHandlingUnit has both a relief air damper and a relief fan, the SingleZoneVAVAirHandlingUnit must indeed have a relief fan.	Link

Annex B.9.6 g36:SingleZoneVAVAirHandlingUnit-WithReliefFanAnnotation

Related Inference Rules

Description	Link
If an instance of s223:AirHandlingUnit matches the constraints defined by g36:SingleZoneVAVAirHandlingUnit and has a relief fan, it will be declared as an instance of this class.	Link

Annex B.9.7 g36:SingleZoneVAVAirHandlingUnit-WithReturnFan

A SingleZoneVAVAirHandlingUnit with a Return fan

Related Constraints

Description	Link
For the case where the SingleZoneVAVAirHandlingUnit has a return fan, the SingleZoneVAVAirHandlingUnit must contain an exhaust air damper with either an analog or two-position damper command property.	Link
For the case where the SingleZoneVAVAirHandlingUnit has a return fan, the SingleZoneVAVAirHandlingUnit must indeed contain a return fan.	Link

Annex B.9.8 g36:SingleZoneVAVAirHandlingUnit-WithReturnFanAnnotation

Related Inference Rules

Description	Link
If an instance of s223:AirHandlingUnit matches the constraints defined by g36:SingleZoneVAVAirHandlingUnit and has a return fan, it will be declared as an instance of that class.	Link

Annex B.9.9 Example Single Zone VAV Air Handling Unit Unit

Single Zone VAV Air Handling Unit Unit based on Figure A-12. [Link to Model](#)

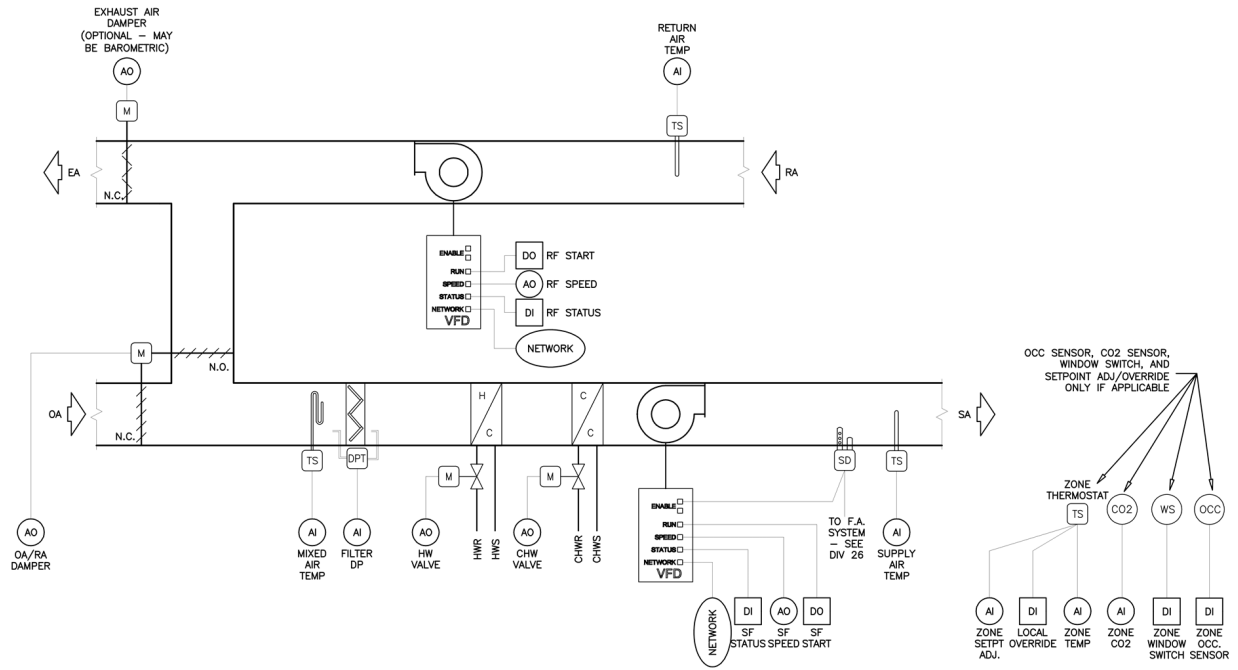

Figure Annex B-9. Guideline 36 Figure A-10.