



BSR/ASHRAE Standard 41.9-2018R

Public Review Draft

Standard Methods for Refrigerant Mass Flow Measurements Using Calorimeters

**First Public Review (November 2020)
(Complete Draft for Full Review)**

This draft has been recommended for public review by the responsible project committee. To submit a comment on this proposed standard, go to the ASHRAE website at www.ashrae.org/standards-research--technology/public-review-drafts and access the online comment database. The draft is subject to modification until it is approved for publication by the Board of Directors and ANSI. Until this time, the current edition of the standard (as modified by any published addenda on the ASHRAE website) remains in effect. The current edition of any standard may be purchased from the ASHRAE Online Store at www.ashrae.org/bookstore or by calling 404-636-8400 or 1-800-727-4723 (for orders in the U.S. or Canada).

The appearance of any technical data or editorial material in this public review document does not constitute endorsement, warranty, or guaranty by ASHRAE of any product, service, process, procedure, or design, and ASHRAE expressly disclaims such.

© 2020 ASHRAE. This draft is covered under ASHRAE copyright. Permission to reproduce or redistribute all or any part of this document must be obtained from the ASHRAE Manager of Standards, 1791 Tullie Circle, NE, Atlanta, GA 30329. Phone: 404-636-8400, Ext. 1125. Fax: 404-321-5478. E-mail: standards.section@ashrae.org.

ASHRAE, 1791 Tullie Circle, NE, Atlanta GA 30329-2305

(This foreword is not part of this standard. It is merely informative and does not contain requirements necessary for conformance to the standard. It has not been processed according to the ANSI requirements for a standard and may contain material that has not been subject to public review or a consensus process. Unresolved objectors on informative material are not offered the right to appeal at ASHRAE or ANSI.)

FOREWORD

This revision of Standard 41.9 is a comprehensive update. The most significant changes are in these portions: (a) the steady-state criteria and (b) the lubricant circulation rate measurement methods. This revision meets with ASHRAE's mandatory language requirements.

1. PURPOSE

This standard prescribes methods for measuring mass flow rates for refrigerants and refrigerant/lubricant mixtures using calorimeters.

2. SCOPE

2.1 This standard applies to measuring mass flow rates for refrigerants and refrigerant/lubricant mixtures using calorimeters in laboratories.

2.2 This standard applies where the entire flow stream of the refrigerant or the refrigerant/lubricant mixture enters the calorimeter as a subcooled liquid and leaves as a superheated vapor (evaporator-type).

2.3 This standard applies where the entire flow stream of the refrigerant or the refrigerant/lubricant mixture enters the calorimeter as a superheated vapor and leaves as a subcooled liquid (condenser-type).

3. DEFINITIONS

The following definitions apply to the terms used in this standard.

accuracy: the degree of conformity of an indicated value to the corresponding *true value*.

calorimeter: a thermally insulated apparatus containing a heat exchanger that determines refrigerant mass flow rate by measuring the heat input/output that will result in a known enthalpy change for the refrigerant.

error: the difference between the test result and its corresponding *true value*.

lubricant circulation rate: the ratio of the mass of lubricant circulating through a refrigerant system to the total mass of refrigerant and lubricant flowing through the system at a specified set of operating conditions.

measurement system: the instruments, signal conditioning systems, if any, and data acquisition system if any.

operating tolerance limit: the upper or lower value of an operating tolerance that is associated with a test point or a targeted set point.

random error: the portion of the total error that varies randomly in repeated measurements of the *true value* throughout a test process.

refrigerant mass flow rate: the mass flow rate of refrigerant potentially mixed with lubricant.

secondary fluid: a fluid of known properties that is used as a heating medium.

secondary refrigerant: a refrigerant of known properties that is used as a heating medium.

subcooling: at a defined pressure, the difference between a given liquid temperature and the bubble point temperature.

superheat: at a defined pressure, the difference between a given vapor temperature and the dew point temperature.

systematic error: the portion of the total error that remains constant in repeated measurements of the *true value* throughout a test process.

targeted set point: a specific set of test conditions where the required refrigerant mass flow rate is known and has an associated operating tolerance.

test point: a specific set of test operating conditions for recording data where the measured required refrigerant mass flow rate is unknown and has an associated operating tolerance.

true value: the unknown, error-free value of a test result.

uncertainty: a determination of the potential error in a measurement that reflects the lack of confidence in the result to a specified level.

unit under test (UUT): a compressor or condensing unit that is the subject of refrigerant mass flow rate measurements.

4. CLASSIFICATIONS

4.1 Calorimeter Types. Calorimeters that are within the scope of this standard are classified either as evaporator calorimeters or as condenser calorimeters.

4.1.1 Evaporator calorimeters:

- a. Secondary refrigerant calorimeter.
- b. Secondary fluid calorimeter.
- c. Primary refrigerant calorimeter.

4.1.2 Condenser calorimeter

5. REQUIREMENTS

5.1 Test Plan. A test plan shall include the test points, targeted set points, and corresponding operating tolerances to be performed. The test plan shall be one of the following options:

- a. A document provided by the person or the organization that authorized the tests and calculations to be performed.

- b. A method of test standard.
- c. A rating standard.
- d. A regulation or code.

5.2 Values to be Determined and Reported. The test values to be determined and reported shall be as shown in Table 1. Use the unit of measure in Table 1 unless otherwise specified in the test plan in Section 5.1.

TABLE 1 Measurement Values and Units of Measure

Quantity	Units of Measure	
	SI	I-P
Refrigerant mass flow rate	kilogram per second (kg/s)	pound (avoirdupois) per hour (lb _m /h)
Uncertainty in the refrigerant mass flow rate	kilogram per second (kg/s)	pound (avoirdupois) per hour (lb _m /h)
Lubricant circulation rate	Dimensionless	Dimensionless

5.3 Refrigerant Mass Flow Rate. Determine the refrigerant mass flow rate, kg/s (lb_m/h), through the unit under test using one of the test methods described in Sections 7 through 10 unless otherwise specified in the test plan in Section 5.1

5.4 Measurement Uncertainty. The uncertainty in each refrigerant mass flow rate measurement, kg/s (lb_m/h), shall be estimated using the methods described in Section 12 for each test point unless otherwise specified in the test plan in Section 5.1. Alternatively, the worst-case uncertainty for all test points shall be estimated and the same value reported for each test point.

5.5 Lubricant Circulation Rate

5.5.1 The lubricant circulation rate through the calorimeter shall not be more than 2% unless otherwise specified in the test plan in Section 5.1.

5.5.2 Lubricant circulation rate measurements shall be made in compliance with Section 11 unless the UUT includes a lubricant separator that limits the lubricant circulation rate to not greater than 1000 ppm.

5.5.3 Any lubricant removed from the refrigerant by a lubricant separator shall be returned to the refrigerant circuit in compliance with Section 5.5.3.1 or 5.5.3.2.

5.5.3.1 If the lubricant separator is integral to the UUT, the lubricant that is removed from the refrigerant in the separator shall be returned to the refrigerant circuit where it is returned in the UUT.

5.5.3.2 If an auxiliary lubricant separator is required, the lubricant from the auxiliary lubricant separator shall be returned to the refrigerant circuit at a location downstream of the calorimeter outlet.

5.6 Lubricant Sampling Port. A sampling port shall be provided for extracting samples of liquid refrigerant and circulating lubricant for use in determining lubricant circulation rates if required by Section 5.5.

Informative Note: Sampling port should be located on a straight section of pipe with minimal flow disturbance nearby. Internal volume between the actual tap point and an isolation valve should be minimized to reduce the quantity of stagnant fluid that will be drawn into the sample vessel.

5.7 Steady-State Criteria for Refrigerant Mass Flow Rate Measurements. Refrigerant mass flow rate test data shall be recorded at steady-state test conditions unless otherwise stated in the test plan in Section 5.1. Section 5.8 describes unsteady-state refrigerant mass flow rate test data recording if required by the test plan.

5.7.1 Steady-State Criteria for Compressors that do not Incorporate Pulse-Width Modulation.

Refrigerant mass flow rate test data shall be recorded at steady-state conditions unless otherwise specified in the test plan in Section 5.1. If the test plan requires refrigerant mass flow rate test data points to be recorded at steady-state test conditions and provides the operating condition tolerance but does not specify the steady-state criteria, then determine that steady-state test conditions have been achieved using one of the following methods:

- a. Apply the steady-state criteria in Section 5.7.1.1 if the test plan provides test points for refrigerant mass flow rate measurement.
- b. Apply the steady-state criteria in Section 5.7.1.2 if the test plan provides targeted set points for refrigerant mass flow rate measurement.

5.7.1.1 Steady-State Refrigerant Mass Flow Rate Criteria for Test Points

Starting with the time set to zero, sample not less than 30 refrigerant mass flow rate measurements N at equal time intervals δt over a test duration Δt where Δt is in time units. Equation 5-1 states the relationship of the test duration to the number of refrigerant mass flow rate samples and the equal time intervals.

$$\Delta t = (N - 1)\delta t \quad (5-1)$$

Informative Note: Circumstances for measurement vary, so the user should select a duration of test and the equal time intervals based upon the longest period of the observed refrigerant mass flow rate fluctuations during operation near the steady-state conditions.

Record each sampled refrigerant mass flow rate measurement \dot{m}_i and the corresponding time t_i . Apply the least-squares line method to determine the slope b of the refrigerant mass flow rate data trend line illustrated in Figure 1 using Equation 5-2.

$$b = \left\{ \frac{[N(\sum_{i=1}^N t_i \dot{m}_i) - (\sum_{i=1}^N t_i)(\sum_{i=1}^N \dot{m}_i)]}{[N(\sum_{i=1}^N t_i^2) - (\sum_{i=1}^N t_i)^2]} \right\} \quad (5-2)$$

Informative Note: It should be noted that the units for the slope in Equation 5-2 are refrigerant mass flow rate, kg/s (lb_m/h), divided by the units that the user has selected for time.

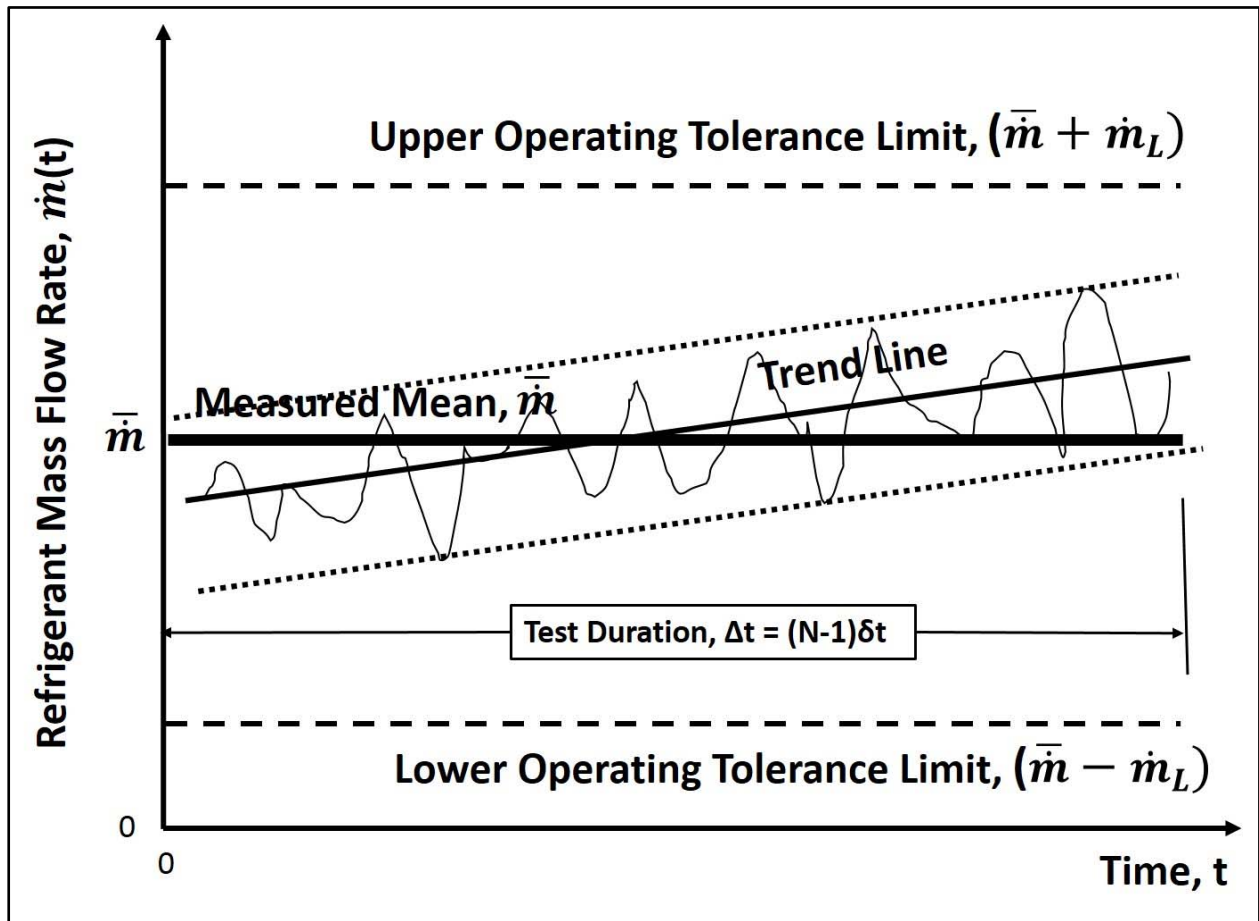

FIGURE 1: Graphical illustration of the method for determining the steady-state refrigerant mass flow rate criteria for test points

Determine the mean offset μ of the sampled data using Equation 5-3, and then calculate the standard deviation σ using Equation 5-4.

$$\mu = \frac{1}{N} [\sum_{i=1}^N (\dot{m}_i - bt_i)], \text{ kg/s (lb}_m\text{/h)} \quad (5-3)$$

$$\sigma = \left[\left(\frac{1}{(N-2)} \right) \sum_{i=1}^N (\dot{m}_i - bt_i - \mu)^2 \right]^{\frac{1}{2}}, \text{ kg/s (lb}_m\text{/h)} \quad (5-4)$$

The mean of the sampled refrigerant mass flow rates \bar{m} is defined by Equation 5-5.

$$\bar{m} = \frac{1}{N} [\sum_{i=1}^N (\dot{m}_i)], \text{ kg/s (lb}_m\text{/h)} \quad (5-5)$$

\bar{m} , as determined by Equation 5-5, represents the steady-state mean refrigerant mass flow rate provided that one of the following criteria is satisfied:

- a. Apply Equation 5-6 if $2\sigma \geq \dot{m}_L$ where \dot{m}_i is the specified operating tolerance limit for refrigerant mass flow rate, and if Equation 5-6 is satisfied by not less than 95% of the sampled refrigerant mass flow rates.

$$|\dot{m}_i - \mu| \leq 2\sigma, \text{ kg/s (lb}_m\text{/h)} \quad (5-6)$$

- b. Apply Equation 5-7 if $\dot{m}_L \geq 2\sigma$ where \dot{m}_L is the specified operating tolerance limit for refrigerant mass flow rate, and if Equation 5-7 is satisfied by not less than 95% of the sampled refrigerant mass flow rates.

$$|\dot{m}_i - \mu| \leq \dot{m}_L, \text{ kg/s (lb}_m\text{/h)} \quad (5-7)$$

Informative Note: For further reading about this method of determining steady-state conditions, refer to Informative Annex A – Bibliography items A1 and A2.

5.7.1.2 Steady-State Refrigerant Mass Flow Rate Criteria for Targeted Set Points

Starting with the time set to zero, sample not less than 30 refrigerant mass flow rate measurements N at equal time intervals δt over a test duration Δt where Δt is in time units. Equation 5-8 states the relationship of the test duration to the number of samples and the equal time intervals.

$$\Delta t = (N - 1)\delta t \quad (5-8)$$

Informative Note: Circumstances for measurement vary, so the user should select a duration of test and the equal time intervals based upon the longest period of the observed refrigerant mass flow rate fluctuations during operation near the steady-state conditions.

Record each sampled refrigerant mass flow rate measurement \dot{m}_i and the corresponding time t_i . Apply the least-squares line method to determine the slope b of the refrigerant mass flow rate data trend line illustrated in Figure 2 using Equation 5-9

$$b = \left\{ \frac{[N(\sum_{i=1}^N t_i \dot{m}_i) - (\sum_{i=1}^N t_i)(\sum_{i=1}^N \dot{m}_i)]}{[N(\sum_{i=1}^N t_i^2) - (\sum_{i=1}^N t_i)^2]} \right\} \quad (5-9)$$

Informative Note: It should be noted that the units for the slope in Equation 5-9 are refrigerant mass flow rate, kg/s (lb_m/h), divided by the units that the user has selected for time.

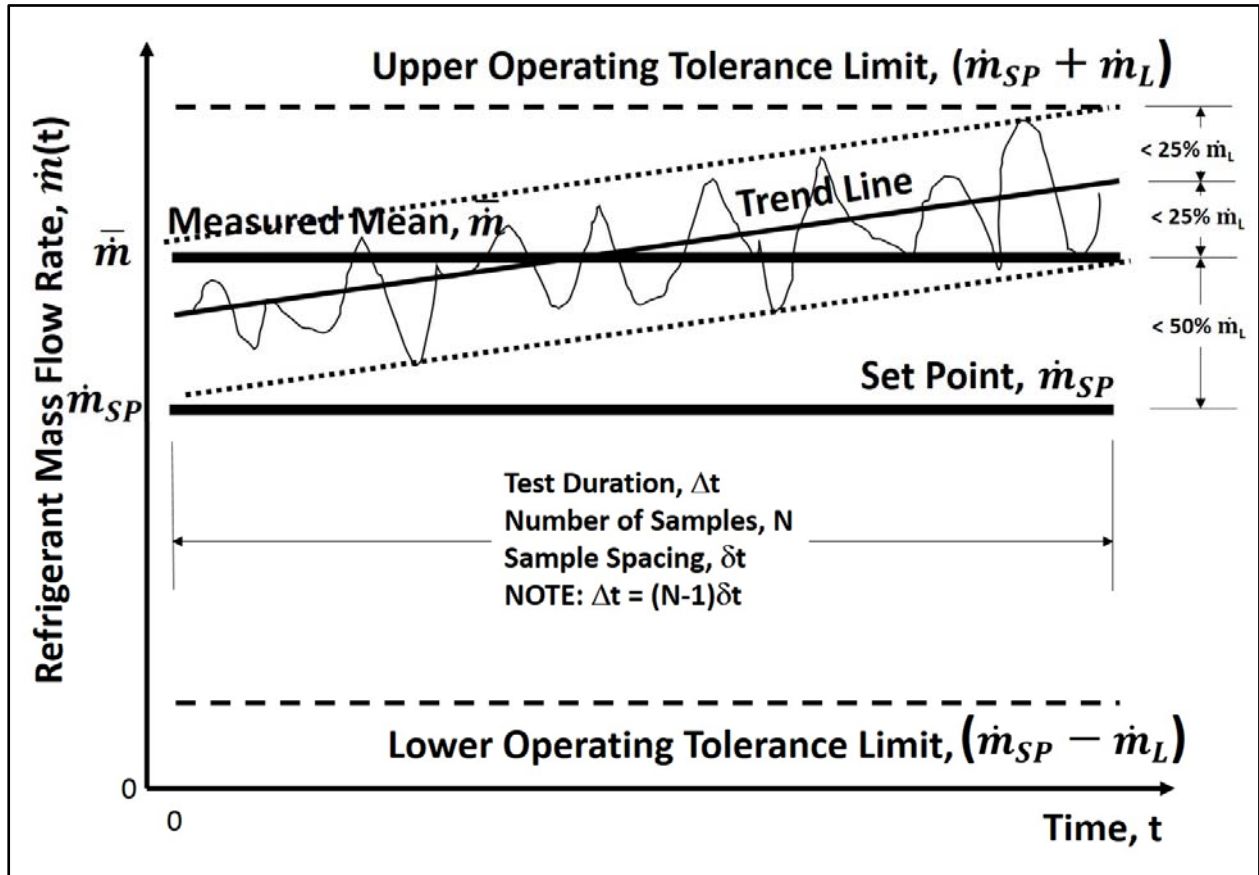

FIGURE 2: Graphical illustration of the method for determining the steady-state refrigerant mass flow rate criteria for targeted set points

Determine the mean offset μ of the sampled data using Equation 5-10 and calculate the standard deviation σ using Equation 5-11.

$$\mu = \frac{1}{N} [\sum_{i=1}^N (\dot{m}_i - bt_i)], \text{ kg/s (lb}_m\text{/h)} \quad (5-10)$$

$$\sigma = \left[\left(\frac{1}{(N-2)} \right) \sum_{i=1}^N (\dot{m}_i - bt_i - \mu)^2 \right]^{\frac{1}{2}}, \text{ kg/s (lb}_m\text{/h)} \quad (5-11)$$

The mean of the sampled refrigerant mass flow rates \bar{m} is defined by Equation 5-12.

$$\bar{m} = \frac{1}{N} [\sum_{i=1}^N (\dot{m}_i)], \text{ kg/s (lb}_m\text{/h)} \quad (5-12)$$

A tolerance on the fluctuations about the trend line represents a limit on the fluctuation level relative to the trend line of the sampled data. If the tolerance of fluctuations about the trend line is not specified in the test plan, the bounds for a 95% confidence limit for the fluctuations about the trend line shall then be determined according to Equation 5-13.

$$|\bar{m} - \dot{m}_{SP}| + |b\Delta t| + 2\sigma \leq \dot{m}_L, \text{ kg/s (lb}_m\text{/h)} \quad (5-13)$$

The steady-state condition of the set point refrigerant mass flow rate \dot{m}_{SP} exists (a) where Equation 5-14 is

satisfied by not less than 95% of the sampled refrigerant mass flow rates where \dot{m}_L is the operating tolerance limit for refrigerant mass flow rate

$$(\dot{m}_{SP} - \dot{m}_L) \leq \dot{m}_i \leq (\dot{m}_{SP} + \dot{m}_L), \text{ kg/s (lb}_m\text{/h)} \quad (5-14)$$

(b) where

$$-0.50 \dot{m}_L \leq (\bar{m} - \dot{m}_{SP}) \leq 0.50 \dot{m}_L, \text{ kg/s (lb}_m\text{/h)} \quad (5-15)$$

and (c) where

$$b\Delta t \leq 0.50\dot{m}_L, \text{ kg/s (lb}_m\text{/h)} \quad (5-16)$$

Informative Note: For further reading about this method of determining steady-state conditions, refer to Informative Annex A – Bibliography items A1 and A2.

5.7.2 Steady-State Criteria for Compressors that Incorporate Pulse-Width Modulation.

Compressors that incorporate pulse-width modulation vary the refrigerant flow rate by alternatively switching the refrigerant flow on-and-off for variable time intervals at a specific frequency. To illustrate the principles, Figure 3 shows the theoretical cycle, modeled as a square-wave, for the refrigerant flow in a pulse-width modulated compressor that is switched on to deliver 50% load.

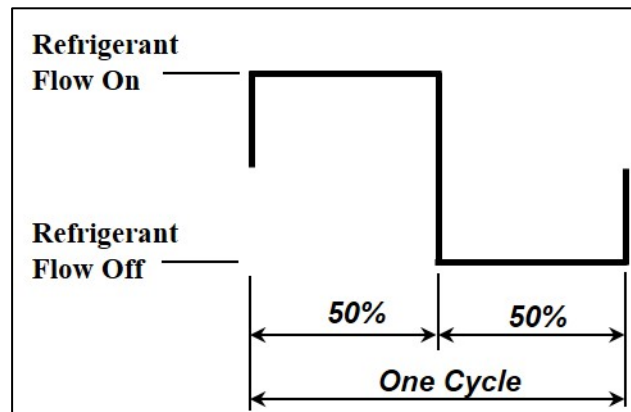

FIGURE 3: Theoretical cycle of refrigerant flow rate for a pulse-width modulated compressor that delivers 50% load

The off-and-on changes in the refrigerant flow illustrated in Figure 5-1 cause comparable changes in (a) suction and discharge temperatures, (b) suction and discharge pressures, and (c) compressor power input if measurement of the compressor power input is required by the test plan in Section 5.1. So, each data sample shall consist of the following recorded measurements:

1. Refrigerant mass flow rate, kg/s (lb_m/h)
2. Suction temperature, °C (°F)
3. Discharge temperature, °C (°F)
4. Suction pressure, kPa (psia)
5. Discharge pressure, kPa (psia)
6. Power input, W (W), if required by the test plan in Section 5.1.

The time interval for recording test samples shall be determined from Equation 5-17 if the load is less than 50%, or from Equation 5-18 if the load is 50% or greater.

$$t_{ts} = \frac{t_{on}}{n} \quad (5-17)$$

$$t_{ts} = \frac{t_{off}}{n} \quad (5-18)$$

where

t_{ts} = time interval between sequential test samples

t_{on} = time interval in each cycle that the refrigerant flow is on

t_{off} = time interval in each cycle that the refrigerant flow is off

n = an integer not less than 5

Each data set is comprised of not less than 30 consecutive cycles of test samples. Not less than 3 sequential data sets shall be recorded for each test data point.

Steady-state operation for a pulse-width modulated compressor shall be established where the following requirements have been achieved unless otherwise specified in the test plan in Section 5.1:

- a. The recording time interval for each data set shall be within $\pm 5\%$ of the average recording time interval for the combined data sets.
- b. The refrigerant mass flow rate recorded for each data set shall be within $\pm 2\%$ of the average refrigerant mass flow rate for the combined data sets.
- c. The pressure and temperature tolerances must be within the test condition tolerances during data recording specified in each calorimeter method.

Informative Note: See Sections 7.7, 8.7, 9.7, and 10.7 for the test condition for each method.

5.8 Unsteady-State Refrigerant Mass Flow Rate Measurements. If required by the test plan in Section 5.1, refrigerant mass flow rate test data shall be recorded:

- a. at operating conditions that are not steady state,
- b. at the time intervals specified in the test plan,
- c. within the test condition limits specified in the test plan,
- d. using instrument response times specified in the test plan.

5.9 Refrigerant Properties. Refrigerant properties shall be obtained from *NIST Reference Fluid Thermodynamic and Transport Properties Database (REFPROP)*¹ or from the refrigerant supplier if a constituent of the refrigerant being tested is not included in REFPROP.

5.10 Input Power. Compressor input power shall be measured in compliance with ASHRAE 41.11² if required by the test plan in Section 5.1.

5.11 Safety Requirements. Test apparatus shall be designed in compliance with ASHRAE 15.³ Materials of construction shall be selected based on refrigerant flammability, toxicity, structural strength, rigidity, corrosion resistance, chemical compatibility with the fluid, and wear resistance.

6. INSTRUMENTS

6.1. Instrumentation Requirements for All Measurements

6.1.1 Instruments and data acquisition systems shall be selected to meet the measurement system accuracy specified in the test plan in Section 5.1.

6.1.2 Measurements from the instruments shall be traceable to primary or secondary standards calibrated by the National Institute of Standards and Technology (NIST) or to the Bureau International des Poids et Mesures (BIPM) if a National Metrology Institute (NMI) other than NIST is used. In either case, the indicated corrections shall be applied to meet the uncertainty stated in subsequent sections. Instruments shall be recalibrated on regular intervals that do not exceed the intervals prescribed by the instrument manufacturer, and calibration records shall be maintained. Instruments shall be installed in compliance with the instrument manufacturer's requirements or the manufacturer's accuracy does not apply.

6.1.3 Instruments shall be applied and used in compliance with the following standards:

- a. Temperature: ASHRAE 41.1⁴
- b. Pressure: ASHRAE 41.3⁵
- c. Lubricant circulation rate: ASHRAE 41.4⁶
- d. Coolant liquid flow rate: ASHRAE 41.8⁷

6.2 Temperature Measurements. If temperature measurements are required by the test plan in Section 5.1, the temperature measurement system accuracy shall be within the following limits unless otherwise specified in the test plan.

- a. Temperature measurement system accuracy shall be within $\pm 0.28^{\circ}\text{C}$ ($\pm 0.5^{\circ}\text{F}$) for laboratory applications.
- b. Temperature difference measurement system accuracy for laboratory applications shall be within $\pm 1.0\%$ of the measured temperature difference but not more accurate than $\pm 0.1\text{ K}$ ($\pm 0.2^{\circ}\text{R}$).

Informative Note: Informative Annex D describes sources of temperature measurement errors.

6.3 Pressure Measurements.

6.3.1 If pressure measurements are required by the test plan in Section 5.1, the pressure measurement system accuracy shall be within $\pm 7\text{ kPa}$ ($\pm 1\text{ psi}$) unless otherwise specified in the test plan. If absolute pressure sensors are not used, the barometric pressure shall be added to the gage pressure readings to obtain absolute pressure values prior to performing uncertainty calculations.

6.3.2 If differential pressure measurements are required by the test plan, the pressure measurement system accuracy shall be within $\pm 1\%$ of the measured pressure difference but not more accurate than $\pm 7\text{ kPa}$ ($\pm 1\text{ psi}$) unless otherwise specified in the test plan. Pressure shall be measured in close proximity to the flow meter in compliance with the flow meter manufacturer's specifications.

6.4 Coolant Liquid Flow Rate Measurements. If the UUT or the selected calorimeter method includes coolant liquid flow rate measurement, the measurement system errors shall be measured within $\pm 1.0\%$ of reading in laboratory applications unless otherwise specified in the test plan in Section 5.1.

6.5 Time Measurements. Time measurement system accuracy shall be within $\pm 0.5\%$ of the elapsed time measured, including any uncertainty associated with starting and stopping the time measurement unless (a) otherwise specified in the test plan in Section 5.1, or (b) a different value for time measurement system accuracy is required to be consistent with the refrigerant flow rate measurement system accuracy specified in the test plan.

6.6 Mass Measurements. If mass measurements are required by the test plan in Section 5.1, the measurement system errors shall be within $\pm 0.2\%$ of the reading unless otherwise specified in the test plan.

7. SECONDARY REFRIGERANT CALORIMETER METHOD

7.1 Equipment Description. A secondary refrigerant calorimeter method, shown schematically in Figure 4, shall consist of two independent fluid circuits located in heat exchange relationship to each other. The primary refrigerant evaporator coil is suspended in the upper portion of an insulated pressure vessel. The secondary refrigerant in the lower portion of the same vessel provides the heat required to evaporate the primary refrigerant. Heat input to the calorimeter is supplied to the liquid portion of the secondary refrigerant. A refrigerant control device that serves as a variable flow restriction shall be included in the calorimeter.

Informative Notes:

1. The refrigerant control device and the refrigerant line to the calorimeter should be insulated.
2. Section 7.4 requires the heat leakage from the calorimeter to be less than 5%.
3. Temperature sensors should be shielded from circulating air as described in Annex D.

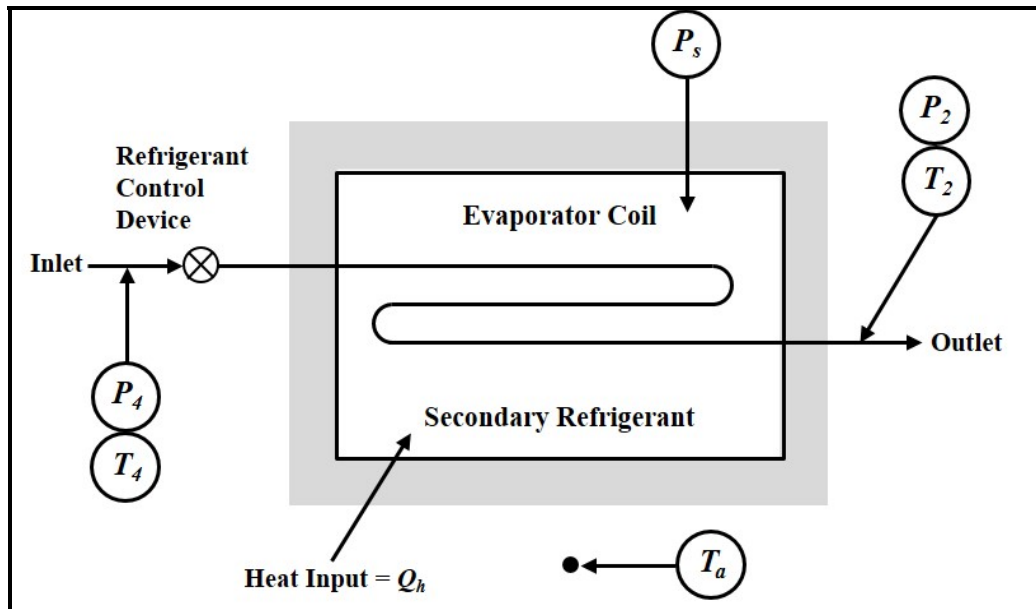

FIGURE 4: Secondary Refrigerant Calorimeter Method

7.2 Calorimeter Safety Features. The calorimeter shall be equipped with (a) a safety switch that will stop the flow of heat into the secondary refrigerant and (b) a spring-actuated or rupture-disk type pressure relief valve. The pressure settings for the safety switch and the pressure relief valve shall be determined by the test equipment manufacturer, and the safety switch setting shall be set to open at 85% of the pressure relief valve.

7.3 Test Data. Test data to be recorded at each steady-state test condition in compliance with Section 5.7:

- a. Primary refrigerant vapor pressure at the evaporator outlet P_2 .
- b. Primary refrigerant vapor temperature at the evaporator outlet T_2 .
- c. Primary refrigerant liquid pressure entering the refrigerant control device P_4 .
- d. Primary refrigerant liquid temperature entering the refrigerant control device T_4 .
- e. Ambient air temperature surrounding the calorimeter T_a .
- f. Secondary refrigerant pressure P_s .
- g. Heat input to the secondary refrigerant Q_h .

- h. Total input power to the UUT, if required by the test plan in Section 5.1.

7.4 Heat Leakage. The heat leakage to the surroundings for each calorimeter shall be measured once and the results shall be applied to all subsequent refrigerant mass flow rate measurements. The heat leakage shall be less than 5% of the heat input to the calorimeter.

Informative Note: Additional insulation is needed if the heat leakage exceeds 5% of the heat input to the calorimeter.

7.4.1 Heat leakage of a secondary refrigerant calorimeter shall be determined as follows:

- a. The ambient temperature around the calorimeter components shall not exceed 49°C (120°F) and shall be stable within ±0.6°C (±1°F) during the test.
- b. With no primary refrigerant circulating, the heat input to the secondary refrigerant shall be set to control the saturated temperature of the secondary refrigerant to not less than 14K (25°R) above ambient temperature and shall be stable within ±0.6°C (±1°F) during the test.
- c. Secondary refrigerant saturated temperature readings shall be recorded at one-hour intervals until four successive saturated temperature reading are within ±0.6°C (±1°F).
- d. This heat leakage test measures the heat leakage out of the calorimeter because $T_s > T_a$, but the leakage into the calorimeter equals the leakage out of the compressor if these temperatures are reversed. For this calorimeter method, the heat leakage is into the calorimeter because the evaporator temperature is less than the ambient temperature during mass flow rate testing.

7.4.2 The heat leakage coefficient shall be determined using Equation 7-1:

$$AU_a = \frac{Q_a}{(T_s - T_a)} \quad (7-1)$$

where

Q_a = calorimeter heat leakage, W (Btu/h)

AU_a = heat leakage coefficient, W-°C (Btu/h-°F)

T_s = secondary refrigerant saturated temperature, °C (°F)

T_a = ambient temperature surrounding the calorimeter, °C (°F)

7.4.3 Heat leakage measured at each test point during subsequent calorimeter tests shall be determined using Equation 7-2:

$$Q_a = AU_a(T_s - T_a) \quad (7-2)$$

where

Q_a = calorimeter heat leakage, W (Btu/h)

AU_a = heat leakage coefficient obtained from Equation 7-1, W-°C (Btu/h-°F)

T_a = ambient temperature surrounding the calorimeter, °C (°F)

T_s = secondary refrigerant saturated temperature, °C (°F)

7.5 Preparations

7.5.1 A sampling port shall be provided for extracting samples of liquid refrigerant and circulating lubricant for use in determining lubricant circulation rates if required by Section 5.5.

7.5.2 The refrigerant system shall be leak tested. Use a vacuum pump to evacuate the refrigerant system to a pressure less than 26.7 Pa (200 microns). After achieving this vacuum, close valves to isolate the refrigerant system from the vacuum pump for not less than 15 minutes. During that time, the pressure shall not be greater than 28.7 Pa (215 microns) unless otherwise specified in the test plan.

7.5.3 If the refrigerant system is not pre-charged with lubricant, install the lubricant charge as prescribed by the UUT manufacturer, and then evacuate the system to less than 26.7 Pa (200 microns) unless otherwise specified in the test plan. Then charge the system with the specified refrigerant type and the quantity of refrigerant required for calorimeter testing.

7.6 Operating Procedures

7.6.1 Vary the refrigerant control to set the calorimeter outlet pressure P_2 specified in the test plan in Section 5.1.

7.6.2 Vary the heat input to the calorimeter to regulate the refrigerant vapor temperature exiting the calorimeter T_2 to achieve the superheat specified in the test plan in Section 5.1.

7.6.3 Vary the condenser cooling flow rate or temperature to set the pressure entering the refrigerant control device P_4 specified in the test plan in Section 5.1.

7.6.4 Set the subcooling specified in the test plan in Section 5.1.

7.6.5 Lubricant circulation rate measurements, if required by Section 5.5, shall be made using the procedures defined in Section 11.

7.7 Test Condition Tolerances during Data Recording

7.7.1 The mean of pressures P_2 and P_4 shall be maintained within $\pm 1\%$ of the pressures specified in the test plan.

7.7.2 Temperature T_2 shall be maintained within $\pm 1^\circ\text{C}$ ($\pm 2^\circ\text{F}$) of the temperature specified in the test plan.

7.7.3 The refrigerant vapor exiting the calorimeter shall have not less than 2.8K (5°R) of superheat.

7.7.4 The refrigerant liquid entering the refrigerant control device shall have not less than 5.6K (10°R) of subcooling and shall be maintained within $\pm 0.6\text{K}$ ($\pm 1^\circ\text{R}$) during the test.

7.7.5 Variations in the ambient air temperature surrounding the calorimeter components shall be limited to within $\pm 4^\circ\text{C}$ ($\pm 7^\circ\text{F}$).

7.8 Refrigerant Mass Flow Rate Calculations. Refrigerant mass flow rates measured using the secondary refrigerant calorimeter method shall be calculated using Equation 7-3:

$$\dot{m} = \frac{(Q_h + Q_a)}{(h_2 - h_4)} \quad (7-3)$$

where:

\dot{m} = refrigerant mass flow rate, kg/s (lb_m/h)

- $Q_h =$ measured heat input to the calorimeter, kW (Btu/h)
- $Q_a =$ calorimeter heat leakage obtained from Equation 7-2, kW (Btu/h)
- $h_2 =$ primary refrigerant vapor enthalpy at the calorimeter outlet, kJ/kg (Btu/lb_m)
- $h_4 =$ primary refrigerant enthalpy at the inlet of the refrigerant control device, kJ/kg (Btu/lb_m)

7.9 Measurement Uncertainty. Measurement uncertainty in the refrigerant mass flow rate measurement shall be estimated using the procedures prescribed in Section 12 as required by Section 5.4.

8. SECONDARY FLUID CALORIMETER METHODS

8.1 Equipment Description. A secondary fluid calorimeter shall consist of two independent fluid circuits located in heat exchange relationship to each other. The refrigerant enters the calorimeter as a subcooled liquid and leaves the calorimeter as a superheated vapor. A secondary fluid with known transport properties circulates through the outer circuit and provides the heat required to evaporate the refrigerant. A refrigerant control device that serves as a variable flow restriction shall be included in the calorimeter.

Informative Notes:

1. The refrigerant control device and the refrigerant line to the calorimeter should be insulated.
2. Section 8.4 requires the heat leakage from the calorimeter to be less than 5%.
3. Temperature sensors should be shielded from circulating air as described in Annex D.

Figure 5 is a schematic of a secondary fluid calorimeter that uses a single-phase liquid as the secondary fluid.

Informative Note: Water and brine are examples of single-phase liquids that are used in secondary fluid calorimeters.

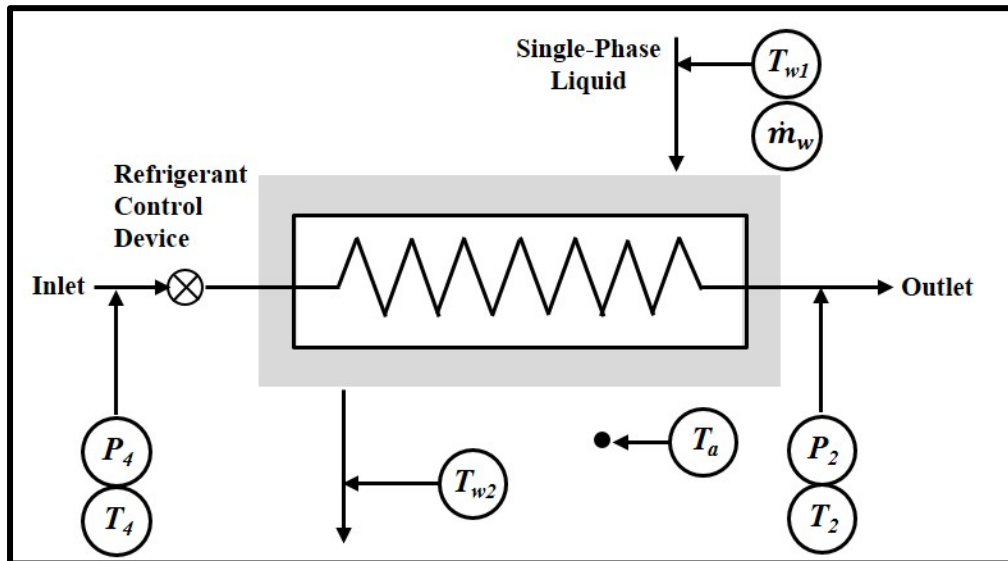

FIGURE 5: Secondary Fluid Calorimeter That Uses a Single-Phase Liquid

Figure 6 is a schematic of a secondary fluid calorimeter that uses a two-phase fluid as the secondary fluid.

Informative Note: Steam is an example of a two-phase fluid that is used in secondary fluid calorimeters.

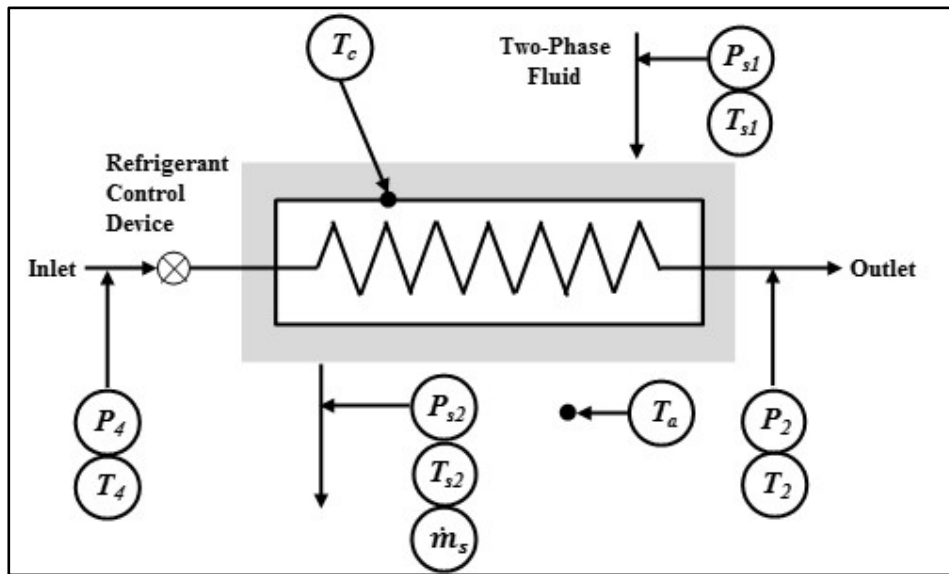

FIGURE 6: Secondary Fluid Calorimeter That Uses a Two-Phase Fluid

8.2 Calorimeter Safety Features. The calorimeter shall be equipped with a safety switch that will stop the flow of heat into the secondary fluid and a spring-actuated or rupture-disk type pressure relief valve. The pressure settings for the safety switch and the pressure relief valve shall be determined by the test equipment manufacturer, and the safety switch setting shall be set to open at 85% of the pressure relief valve.

8.3 Test Data

8.3.1 Single-Phase Liquid Secondary Fluid. Test data to be recorded at each steady-state test condition in compliance with Section 5.7 where a single-phase liquid is used as the secondary fluid:

- Refrigerant vapor pressure at the evaporator outlet P_2 .
- Refrigerant vapor temperature at the evaporator outlet T_2 .
- Liquid refrigerant pressure at the refrigerant control device inlet P_4 .
- Liquid refrigerant temperature at the refrigerant control device inlet T_4 .
- Ambient air temperature surrounding the calorimeter T_a .
- Single-phase liquid temperature entering the calorimeter T_{w1} .
- Single-phase liquid temperature exiting the calorimeter T_{w2} .
- Single-phase liquid mass flow rate \dot{m}_w .
- Total input power to the UUT, if required by the test plan in Section 5.1.

8.3.2 Two-Phase Secondary Fluid. Test data to be recorded at each steady-state test condition in compliance with Section 5.7 where a two-phase fluid is used as the secondary fluid:

- a. Refrigerant vapor pressure at the evaporator outlet P_2 .
- b. Refrigerant vapor temperature at the evaporator outlet T_2 .
- c. Liquid refrigerant pressure at the refrigerant control device inlet P_4 .
- d. Liquid refrigerant temperature at the refrigerant control device inlet T_4 .
- e. Ambient air temperature surrounding the calorimeter T_a .
- f. Two-phase fluid temperature entering the calorimeter T_{s1} .
- g. Two-phase fluid pressure in the calorimeter P_{s1} .
- h. Two-phase fluid temperature exiting the calorimeter T_{s2} .
- i. Two-phase fluid mass flow rate \dot{m}_s .
- j. Surface temperature of the pressure vessel T_c .
- k. Total input power to the UUT, if required by the test plan in Section 5.1.

8.4 Heat Leakage. The heat leakage to the surroundings for each calorimeter shall be measured once, and the results shall be applied to all subsequent refrigerant flow rate measurements. The heat leakage shall be less than 5% of the heat input to the calorimeter.

Informative Note: Additional insulation is needed if the heat leakage exceeds 5% of the heat input to the calorimeter.

8.4.1 Heat leakage of the calorimeter shall be determined by circulating the heating medium through the outer circuit of the calorimeter when there is no load other than heat leakage. This heat leakage test measures the heat leakage out of the calorimeter, but the leakage into the calorimeter equals the leakage out of the compressor if the temperatures used in this heat leakage test are reversed. For this calorimeter method, the heat leakage is into the calorimeter because the evaporator temperature is less than the ambient temperature during mass flow rate testing.

8.4.1.1 If single-phase liquid is used, the temperature difference between single-phase liquid entering and exiting the calorimeter shall be not less than 14K (25°R) above the ambient temperature. The ambient temperature shall be not more than 32°C (90°F) and shall be stable within $\pm 0.6^\circ\text{C}$ ($\pm 1^\circ\text{F}$) during the test. The test shall be continued until four successive single-phase liquid inlet and outlet temperatures taken at one-hour intervals show variations not more than $\pm 0.1^\circ\text{C}$ ($\pm 0.2^\circ\text{F}$) at constant flow rates.

8.4.1.2 If two-phase fluid is used as the heating medium, heat leakage of the calorimeter shall be determined by collecting and weighing the two-phase fluid condensate from the heating medium circuit. The two-phase fluid pressure shall be within ± 4 kPa (± 0.5 psi) at the selected pressure. The ambient temperature shall be not more than 32°C (90°F) and shall be stable within $\pm 0.6^\circ\text{C}$ ($\pm 1^\circ\text{F}$) during the test. The two-phase fluid superheat shall be not less than 4.4K (8°R). The test shall be continued until four successive readings of condensate weight taken at not less than one-hour intervals are within 1% of each other.

The heat leakage coefficient shall be determined using Equation 8-1 for a single-phase liquid, and from Equation 8-2 for a two-phase fluid:

$$AU_a = \frac{\dot{m}_w c_p (T_{w1} - T_{w2})}{[0.5(T_{w1} + T_{w2}) - T_a]} \quad (8-1)$$

$$AU_a = \frac{\dot{m}_s(h_{s4} - h_{s2})}{(T_c - T_a)} \quad (8-2)$$

where

AU_a = heat leakage coefficient, kW/°C ((Btu/(h-°F))

\dot{m}_w = single-phase liquid mass flow rate, kg/s (lb_m/h)

\dot{m}_s = two-phase fluid mass flow rate, kg/s (lb_m/h)

c_p = single-phase liquid constant pressure specific heat at the average temperature, $(T_{w1} + T_{w2})/2$, kJ/kg-°C (Btu/(lb_m-°F))

h_{s4} = two-phase fluid enthalpy entering the calorimeter, kJ/kg (Btu/lb_m)

h_{s2} = two-phase fluid enthalpy exiting the calorimeter, kJ/kg (Btu/lb_m)

T_a = ambient temperature surrounding the calorimeter, °C (°F)

T_c = surface temperature of the pressure vessel if two-phase fluid is used, °C (°F)

T_{w1} = single-phase liquid temperature entering the calorimeter, °C (°F)

T_{w2} = single-phase liquid temperature exiting the calorimeter, °C (°F)

8.4.3 Heat leakage measured at each test point during subsequent calorimeter tests shall be determined using Equation 8-3 for a single-phase liquid, and using Equation 8-4 for a two-phase fluid:

$$Q_a = AU_a[0.5(T_{w1} + T_{w2}) - T_a] \quad (8-3)$$

$$Q_a = AU_a(T_c - T_a) \quad (8-4)$$

where

Q_a = calorimeter heat leakage, kW (Btu/h)

AU_a = heat leakage coefficient, kW/°C ((Btu/(h-°F))

T_a = ambient temperature surrounding the calorimeter, °C (°F)

T_c = mean surface temperature of the pressure vessel if a two-phase fluid is used, °C (°F)

T_{w1} = single-phase liquid temperature entering the calorimeter, °C (°F)

T_{w2} = single-phase liquid temperature exiting the calorimeter, °C (°F)

8.5 Preparations

8.5.1 A sampling port shall be provided for extracting samples of liquid refrigerant and circulating lubricant for use in determining lubricant circulation rates if required by Section 5.5.

8.5.2 The refrigerant system shall be leak tested. Use a vacuum pump to evacuate the refrigerant system to a pressure less than 26.7 Pa (200 microns). After achieving this vacuum, close valves to isolate the refrigerant system from the vacuum pump for not less than 15 minutes. During that time, the pressure shall not be greater than 28.7 Pa (215 microns) unless otherwise specified in the test plan.

8.5.3 If the refrigerant system is not pre-charged with lubricant, install the lubricant charge as prescribed by the UUT manufacturer, and then evacuate the system to less than 26.7 Pa (200 microns) unless otherwise specified in the test plan. Then charge the system with the specified refrigerant type and the quantity of refrigerant required for calorimeter testing.

8.6 Operating Procedures

8.6.1 Vary the refrigerant control to set the calorimeter outlet pressure P_2 in compliance with the test plan in Section 5.1.

8.6.2 Vary the heat input to the calorimeter to regulate the refrigerant vapor temperature exiting the calorimeter T_2 to achieve the superheat specified in the test plan in Section 5.1.

8.6.3 Vary the condenser cooling flow rate or temperature to set the pressure entering the refrigerant control device P_4 specified in the test plan in Section 5.1.

8.6.4 Set the subcooling specified in the test plan in Section 5.1.

8.6.5 Lubricant circulation rate measurements, if required by Section 5.5, shall be made using the procedures defined in Section 11.

8.7 Test Condition Tolerances during Data Recording

8.7.1 The mean of pressures P_2 and P_4 shall be maintained within $\pm 1\%$ of the pressures specified in the test plan.

8.7.2 Temperature T_2 shall be maintained within $\pm 1^\circ\text{C}$ ($\pm 2^\circ\text{F}$) of the temperature specified in the test plan.

8.7.3 The refrigerant vapor exiting the calorimeter shall have not less than 2.8K (5°R) of superheat.

8.7.4 The refrigerant liquid entering the refrigerant control device shall have not less than 5.6K (10°R) of subcooling and shall be maintained within $\pm 0.6\text{K}$ ($\pm 1^\circ\text{R}$) during the test.

8.7.5 Variations in the ambient air temperature surrounding the calorimeter shall be limited to within $\pm 4^\circ\text{C}$ ($\pm 7^\circ\text{F}$).

8.8 Calculations. Refrigerant mass flow rates measured using the secondary fluid method shall be calculated using Equation 8-5 for a single-phase liquid, and using Equation 8-6 for a two-phase fluid:

$$\dot{m} = \frac{\dot{m}_w c (T_{w1} - T_{w2}) - Q_a}{(h_2 - h_4)} \quad (8-5)$$

$$\dot{m} = \frac{[\dot{m}_w - (h_{s4} - h_{s2}) - Q_a]}{(h_2 - h_4)} \quad (8-6)$$

where:

\dot{m} = refrigerant mass flow rate, kg/s (lb_m/h)

\dot{m}_s = two-phase fluid mass flow rate, kg/s (lb_m/h)

\dot{m}_w = single-phase fluid mass flow rate, kg/s (lb_m/h)

c = single-phase liquid constant pressure specific heat at the average temperature, $(T_{w1} + T_{w2})/2$, kJ/kg- $^\circ\text{C}$ (Btu/ (lb_m - $^\circ\text{F}$))

- h_{s4} = two-phase fluid enthalpy entering the calorimeter, kJ/kg (Btu/lb_m)
- h_{s2} = two-phase fluid enthalpy exiting the calorimeter, kJ/kg (Btu/lb_m)
- h_4 = refrigerant liquid enthalpy entering the refrigerant control device, kJ/kg (Btu/lb_m)
- h_2 = refrigerant vapor enthalpy exiting the calorimeter, kJ/kg (Btu/lb_m)
- T_{w1} = single-phase liquid temperature entering the calorimeter, °C (°F)
- T_{w2} = single-phase liquid temperature exiting the calorimeter, °C (°F)
- Q_a = calorimeter heat leakage, kW (Btu/h)

8.9 Measurement Uncertainty. Measurement uncertainty in the refrigerant mass flow rate measurement shall be estimated using the procedures prescribed in Section 12 as required by Section 5.4.

9. PRIMARY REFRIGERANT CALORIMETER METHOD

9.1 Equipment Description. The primary refrigerant calorimeter method, shown schematically in Figure 7, consists of an arrangement of refrigerant tubes or tubular vessels designed to evaporate the refrigerant flow. Heat input shall be provided by an electric heating device appropriate to the evaporator configuration. A refrigerant control device that serves as a flow restriction shall be included in the calorimeter.

Informative Notes:

1. The refrigerant control device and the refrigerant line to the calorimeter should be insulated.
2. Section 9.4 requires the heat leakage from the calorimeter to be less than 5%.
3. Temperature sensors should be shielded from circulating air as described in Annex D.

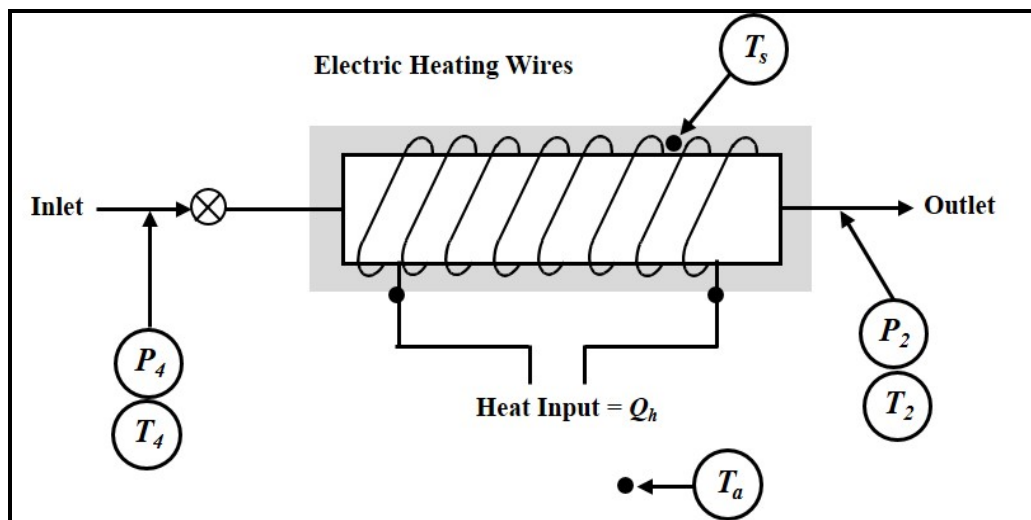

FIGURE 7: Primary Refrigerant Calorimeter Method

9.2 Calorimeter Safety Features. The calorimeter shall be equipped with a safety switch that will stop the flow of heat input and a spring-actuated or rupture-disk type pressure relief valve. The pressure settings for the safety switch and the pressure relief valve shall be determined by the test equipment manufacturer, and the safety switch setting shall be set to open at 85% of the pressure relief valve.

9.3 Test Data. Test data to be recorded at each steady-state test condition in compliance with Section 5.7:

- a. Refrigerant vapor pressure at the evaporator outlet P_2 .
- b. Refrigerant vapor temperature at the evaporator outlet T_2 .

- c. Liquid refrigerant pressure entering the refrigerant control device P_4 .
- d. Liquid refrigerant temperature entering the refrigerant control device T_4 .
- e. Ambient air temperature surrounding calorimeter T_a .
- f. Calorimeter heat input Q_h .
- g. Surface temperature of the pressure vessel T_s .
- h. Total input power to the UUT if required by the test plan in Section 5.1.

9.4 Heat Leakage. The heat leakage to the surroundings for each calorimeter shall be measured once and the results shall be applied to all subsequent refrigerant flow rate measurements. The heat leakage shall be less than 5% of the heat input to the calorimeter.

Informative Note: Additional insulation is needed if the heat leakage exceeds 5% of the heat input to the calorimeter.

9.4.1 Heat leakage of a primary refrigerant calorimeter shall be determined as follows:

- a. The ambient temperature around the calorimeter shall not exceed 49°C (120°F) and shall be stable within $\pm 0.6^\circ\text{C}$ ($\pm 1^\circ\text{F}$) during the test.
- b. With no refrigerant circulating, the heat input to the refrigerant shall be set to control the surface temperature T_s to not less than 14K (25°R) above ambient temperature and shall be stable within $\pm 0.6\text{K}$ ($\pm 1^\circ\text{R}$) during the test.
- c. Surface temperature readings shall be recorded at one-hour intervals until four successive saturated temperature readings are within $\pm 0.6^\circ\text{C}$ ($\pm 1^\circ\text{F}$).
- d. This heat leakage test measures the heat leakage out of the calorimeter, but the leakage into the calorimeter equals the leakage out of the compressor if the temperatures used in this heat leakage test are reversed. For this calorimeter method, the heat leakage is into the calorimeter because the evaporator temperature is less than the ambient temperature during mass flow rate testing.

9.4.2 The heat leakage coefficient shall be determined using Equation 9-1:

$$AU_a = \frac{Q_a}{(T_s - T_a)} \quad (9-1)$$

where

Q_a = calorimeter heat leakage, W (Btu/h)

AU_a = heat leakage coefficient, W/°C (Btu/h-°F)

T_s = surface temperature, °C (°F)

T_a = ambient temperature surrounding the calorimeter, °C (°F)

9.4.3 Heat leakage measured at each test point during subsequent calorimeter tests shall be determined using Equation 9-2:

$$Q_a = AU_a(T_s - T_a) \quad (9-2)$$

where

Q_a = calorimeter heat leakage, W (Btu/h)

AU_a = heat leakage coefficient obtained from Equation 9-1, W/°C (Btu/h-°F)

T_s = surface temperature, °C (°F)

T_a = ambient temperature around the calorimeter, °C (°F)

9.5 Preparations

9.5.1 A sampling port shall be provided for extracting samples of liquid refrigerant and circulating lubricant for use in determining lubricant circulation rates if required by Section 5.5.

9.5.2 The refrigerant system shall be leak tested. Use a vacuum pump to evacuate the refrigerant system to a pressure less than 26.7 Pa (200 microns). After achieving this vacuum, close valves to isolate the refrigerant system from the vacuum pump for not less than 15 minutes. During that time, the pressure shall not be greater than 28.7 Pa (215 microns) unless otherwise specified in the test plan.

9.5.3 If the refrigerant system is not pre-charged with lubricant, install the lubricant charge as prescribed by the UUT manufacturer, and then evacuate the system to less than 26.7 Pa (200 microns) unless otherwise specified in the test plan. Then charge the system with the specified refrigerant type and the quantity of refrigerant required for calorimeter testing.

9.6 Operating Procedures

9.6.1 Vary the refrigerant control to set the calorimeter outlet pressure P_2 specified in the test plan in Section 5.1.

9.6.2 Vary the heat input to the calorimeter to regulate the refrigerant vapor temperature exiting the calorimeter T_2 to achieve the superheat specified in the test plan in Section 5.1.

9.6.3 Vary the condenser cooling flow rate or temperature to set the pressure entering the refrigerant control device P_4 specified in the test plan in Section 5.1.

9.6.4 Set the subcooling specified in the test plan in Section 5.1.

9.6.5 Lubricant circulation rate measurements, if required by Section 5.5, shall be made using the procedures defined in Section 11.

9.7 Test Condition Tolerances during Data Recording

9.7.1 The mean of pressures P_2 and P_4 shall be maintained within $\pm 1\%$ of the pressures specified in the test plan.

9.7.2 Temperature T_2 shall be maintained within $\pm 1^\circ\text{C}$ ($\pm 2^\circ\text{F}$) of the temperature specified in the test plan.

9.7.3 The refrigerant vapor exiting the calorimeter shall have not less than 2.8K (5°R) of superheat.

9.7.4 The liquid entering the refrigerant control device shall have not less than 6K (10°R) of subcooling and be maintained within $\pm 0.6\text{K}$ ($\pm 1^\circ\text{R}$).

9.7.5 Variations in the ambient air temperature surrounding the calorimeter shall be limited to within $\pm 4^\circ\text{C}$ ($\pm 7^\circ\text{F}$).

9.8 Calculations. Refrigerant mass flow rates measured using the primary refrigerant calorimeter method shall be calculated using Equation 9-3:

$$\dot{m} = \frac{(Q_h + Q_a)}{(h_2 - h_4)} \quad (9-3)$$

where

- \dot{m} = refrigerant mass flow rate, kg/s (lb_m/h)
- Q_h = measured heat input to the calorimeter, kW (Btu/h)
- Q_a = calorimeter heat leakage obtained from Equation 9-2, kW (Btu/h)
- h_2 = refrigerant vapor enthalpy exiting the calorimeter, kJ/kg (Btu/lb_m)
- h_4 = refrigerant liquid enthalpy entering the refrigerant control device, kJ/kg (Btu/lb_m)

9.9 Measurement Uncertainty. Measurement uncertainty in the refrigerant mass flow rate measurement shall be estimated using the procedures prescribed in Section 12 as required by Section 5.4.

10. CONDENSER CALORIMETER METHOD

10.1 Equipment Description. The condenser calorimeter method, shown schematically in Figure 8, consists of a heat exchanger that is cooled by a single-phase liquid with known transport properties and capable of condensing superheated refrigerant vapor and producing subcooled refrigerant liquid.

Informative Notes:

1. Water is an example of a single-phase liquid with known transport properties.
2. The refrigerant lines entering and exiting the calorimeter should be insulated.
3. Section 10.4 requires the heat leakage from the calorimeter to be less than 5%.
4. Temperature sensors should be shielded from circulating air as described in Annex D.

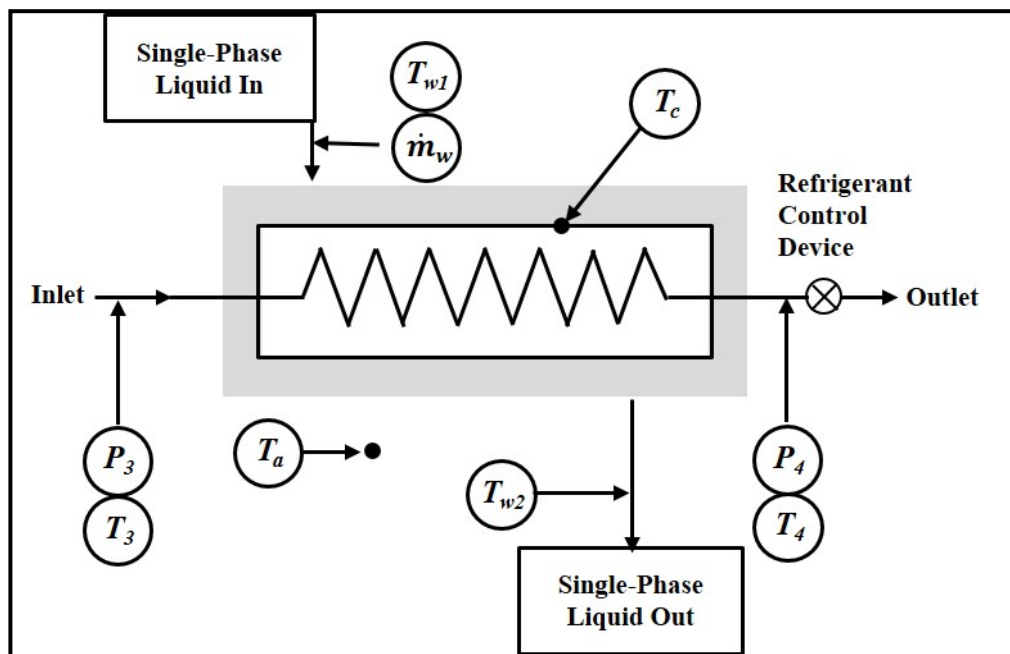

FIGURE 8: Condenser Calorimeter Method

10.2 Calorimeter Safety Features. The calorimeter shall be equipped with a safety switch that will stop the flow of heat into the refrigerant and a spring-actuated or rupture-disk type pressure relief valve. The pressure settings for the safety switch and the pressure relief valve shall be determined by the test equipment manufacturer, and the safety switch setting shall be set to open at 85% of the pressure relief valve.

10.3 Test Data. Test data to be recorded at each steady-state test condition in compliance with Section 5.6:

- a. Refrigerant vapor pressure entering the condenser P_3 .
- b. Refrigerant vapor temperature entering the condenser T_3 .
- c. Pressure of the liquid refrigerant exiting the condenser P_4 .
- d. Liquid refrigerant temperature exiting the condenser T_4 .
- e. Single-phase liquid temperature entering the condenser T_{w1} .
- f. Single-phase liquid temperature exiting the condenser T_{w2} .
- g. Ambient temperature surrounding the calorimeter T_a .
- h. Single-phase liquid mass flow rate \dot{m}_w .
- i. Surface temperature of the pressure vessel T_c .
- j. Total input power to the UUT if required by the test plan in Section 5.1.

10.4 Heat Leakage. The heat leakage to the surroundings for each calorimeter shall be measured once, and the results shall be applied to all subsequent refrigerant flow rate measurements. The heat leakage shall be less than 5% of the heat input to the calorimeter.

Informative Note: Additional insulation is needed if the heat leakage exceeds 5% of the heat input to the calorimeter.

Heat leakage shall be determined using Equation 10-1:

$$Q_a = AU_a(T_c - T_a) \quad (10-1)$$

where

- Q_a = calorimeter heat leakage, kW (Btu/h)
- A = outside surface area of the condenser, m^2 (ft^2)
- U_a = condenser-to-air heat transfer coefficient: $U_a = 10 \text{ W}/(m^2 \cdot ^\circ\text{C})$ [$\text{Btu}/(\text{h} \cdot \text{ft}^2 \cdot ^\circ\text{F})$]
- T_c = surface temperature of the pressure vessel, $^\circ\text{C}$ ($^\circ\text{F}$)
- T_a = ambient temperature, $^\circ\text{C}$ ($^\circ\text{F}$)

10.5 Preparations

10.5.1 A sampling port shall be provided for extracting samples of liquid refrigerant and circulating lubricant for use in determining lubricant circulation rates if required by Section 5.5.

10.5.2 The refrigerant system shall be leak tested. Use a vacuum pump to evacuate the refrigerant system to a pressure less than 26.7 Pa (200 microns). After achieving this vacuum, close valves to isolate the refrigerant system from the vacuum pump for not less than 15 minutes. During that time, the pressure shall not be greater than 28.7 Pa (215 microns) unless otherwise specified in the test plan.

10.5.3 If the refrigerant system is not pre-charged with lubricant, install the lubricant charge as prescribed by the UUT manufacturer, and then evacuate the system to less than 26.7 Pa (200 microns)

unless otherwise specified in the test plan. Then charge the system with the specified refrigerant type and the quantity of refrigerant required for calorimeter testing.

10.6 Operating Procedures

10.6.1 Vary the refrigerant control device to set the condenser outlet pressure P_4 specified in the test plan in Section 5.1.

10.6.2 Vary the heat output from the condenser to regulate the refrigerant liquid temperature exiting the condenser T_4 to achieve the subcooling specified in the test plan in Section 5.1.

10.6.3 Set the pressure entering the condenser P_3 specified in the test plan in Section 5.1.

10.6.4 Lubricant circulation rate measurements, if required by Section 5.5, shall be made using the procedures defined in Section 11.

10.7 Test Condition Tolerances during Data Recording

10.7.1 The mean of pressures P_3 and P_4 shall be maintained within $\pm 1\%$ of the pressures specified in the test plan.

10.7.2 Temperature T_4 shall be maintained within $\pm 1^\circ\text{C}$ ($\pm 2^\circ\text{F}$) of the temperature specified in the test plan.

10.7.3 The liquid entering the refrigerant control device shall have not less than 6K (10°R) of subcooling and be maintained within $\pm 0.6\text{K}$ ($\pm 1^\circ\text{R}$).

10.7.4 Variations in the ambient air temperature surrounding the calorimeter shall be limited to within $\pm 4^\circ\text{C}$ ($\pm 7^\circ\text{F}$).

10.8 Refrigerant Mass Flow Rate Calculations. The refrigerant mass flow rate measured using the condenser calorimeter method shall be calculated using Equation 10-2:

$$\dot{m} = \frac{\dot{m}_w c_p (T_{w2} - T_{w1}) + Q_a}{(h_3 - h_4)} \quad (10-2)$$

where

\dot{m} = refrigerant mass flow rate, kg/s (lb_m/h)

\dot{m}_w = single-phase liquid mass flow rate, kg/s (lb_m/h)

c_p = constant pressure specific heat of single-phase liquid at the average temperature, $(t_{w1} + t_{w2})/2$, kJ/(kg- °C), (Btu/(lb_m- °F))

T_{w1} = single-phase liquid temperature entering the calorimeter, °C (°F)

T_{w2} = single-phase liquid temperature exiting the calorimeter, °C (°F)

Q_a = calorimeter heat leakage obtained from Equation 10-1, kW (Btu/h)

h_3 = refrigerant vapor enthalpy entering the calorimeter, kJ/kg (Btu/lb_m)

h_4 = refrigerant liquid enthalpy exiting the calorimeter, kJ/kg (Btu/lb_m)

10.9 Measurement Uncertainty. Measurement uncertainty in the refrigerant mass flow rate measurement shall be estimated using the procedures prescribed in Section 12 as required by Section 5.4.

11. LUBRICANT CIRCULATION RATE MEASUREMENTS

11.1 Symbols. Table 2 defines the symbols used in Section 11.

Symbol	Description	SI Units	I-P Units
C_c	Lubricant circulation rate through the calorimeter, %		dimensionless
C_s	Lubricant circulation rate through the lubricant separator, %		dimensionless
C_{suut}	Lubricant circulation rate through the UUT, %		dimensionless
\dot{m}_{lc}	Lubricant mass flow rate through the calorimeter	kg/s	lb _m /h
\dot{m}_{ls}	Lubricant mass flow rate through the auxiliary separator	kg/s	lb _m /h
\dot{m}_{lt}	Total lubricant mass flow rate	kg/s	lb _m /h
\dot{m}_{rc}	Refrigerant mass flow rate through the calorimeter	kg/s	lb _m /h
\dot{m}_{rs}	Refrigerant mass flow rate through the auxiliary separator	kg/s	lb _m /h
\dot{m}_{rt}	Total refrigerant mass flow rate	kg/s	lb _m /h
\dot{m}_{rls}	Total refrigerant/lubricant mass flow rate through the auxiliary separator	kg/s	lb _m /h

TABLE 2 Symbols Used in Section 11

11.2 Lubricant Circulation Rate Measurement without an Auxiliary Lubricant Separator

11.2.2 Measure the refrigerant mass flow rate through the calorimeter \dot{m}_{rc} using one of the calorimeter test methods in Sections 7 through 10 if required by the test plan in Section 5.1.

11.2.3 Apply the procedures prescribed in ASHRAE 41.4⁶ to determine the lubricant circulation rate through the calorimeter C_c . Refer to Section 5.6 for sample port requirements.

11.3 Lubricant Circulation Rate Measurement with an Auxiliary Lubricant Separator

11.3.1 Figure 9 is a schematic of the auxiliary lubricant separator.

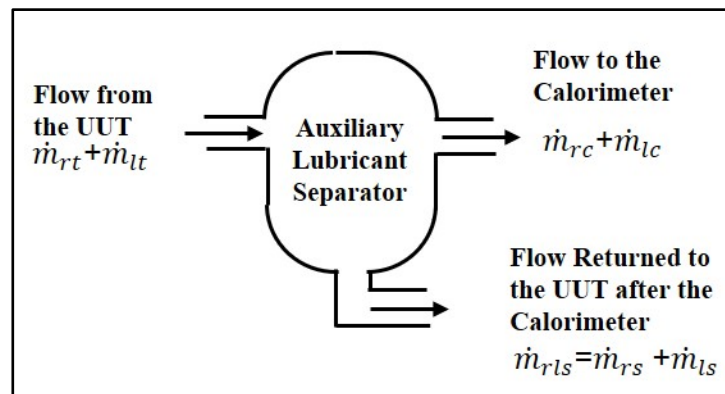

FIGURE 9: Auxiliary Lubricant Separator Schematic

11.3.2 Measure the refrigerant mass flow rate through the calorimeter \dot{m}_{rc} using one of the calorimeter test methods described in Sections 7 through 10.

11.3.3 Apply the procedures in ASHRAE 41.4⁶ to determine the lubricant circulation rate through the calorimeter C_c . Refer to Section 5.6 for sample port requirements.

$$C_c = \frac{\dot{m}_{lc}}{(\dot{m}_{rc} + \dot{m}_{lc})} \times 100 \text{ percent} \quad (11-1)$$

Informative Note: Equations 11-2 through 11-12 define the procedure for deriving Equation 11-13, the equation that users will apply to calculate the lubricant circulation rate when an auxiliary separator is added to the UUT.

11.3.4 Measure the total refrigerant plus lubricant mass flow rate through the auxiliary lubricant separator \dot{m}_{rls} using a liquid flowmeter mass flow rate method in ASHRAE Standard 41.8⁷ with an accuracy not greater than $\pm 1\%$ of the rate.

11.3.5 Apply the procedures in ASHRAE Standard 41.4⁶ to determine the lubricant circulation rate through the auxiliary lubricant separator C_s . Refer to Section 5.6 for sample port requirements.

$$C_s = \frac{\dot{m}_{ls}}{(\dot{m}_{rs} + \dot{m}_{ls})} \times 100 \text{ percent} \quad (11-2)$$

11.3.6 From the conservation of mass, the refrigerant plus lubricant mass flow rate through the auxiliary lubricant separator \dot{m}_{rls} is equal to the sum of the refrigerant mass flow rate through the auxiliary lubricant separator \dot{m}_{rs} and the lubricant mass flow rate through the auxiliary lubricant separator \dot{m}_{ls} as stated in Equation 11-3.

$$\dot{m}_{rls} = \dot{m}_{rs} + \dot{m}_{ls} \quad (11-3)$$

11.3.7 Equation 11-4 is an expression for the refrigerant mass flow rate through the auxiliary lubricant separator \dot{m}_{rs} that is obtained from Equation 11-2.

$$\dot{m}_{rs} = \dot{m}_{ls} \left(\frac{1 - C_s}{C_s} \right) \quad (11-4)$$

11.3.8 Equation 11-5, the refrigerant mass flow rate through the auxiliary lubricant separator \dot{m}_{rs} is obtained by substituting Equation 11-4 into Equation 11-3.

$$\dot{m}_{rs} = \dot{m}_{rls} (1 - C_s) \quad (11-5)$$

11.3.9 Equation 11-6, the refrigerant mass flow rate through the auxiliary lubricant separator \dot{m}_{ls} is obtained by substituting Equation 11-5 into Equation 11-3.

$$\dot{m}_{ls} = C_s \dot{m}_{rls} \quad (11-6)$$

11.3.10 From the conservation of mass, the total lubricant mass flow rate \dot{m}_{lt} is equal to the sum of the lubricant mass flow rate through the calorimeter \dot{m}_{lc} and the lubricant mass flow rate through the auxiliary lubricant separator \dot{m}_{ls} .

$$\dot{m}_{lt} = \dot{m}_{lc} + \dot{m}_{ls} \quad (11-7)$$

11.3.11 An expression for the lubricant mass flow rate through the calorimeter \dot{m}_{lc} is obtained from Equation 11-1.

$$\dot{m}_{lc} = \dot{m}_{rc} \left(\frac{C_c}{1-C_c} \right) \quad (11-8)$$

11.3.12 Equation 11-9, the total lubricant mass flow rate \dot{m}_{lt} is obtained by substituting Equation 11-8 and Equation 11-6 into Equation 11-7.

$$\dot{m}_{lt} = \dot{m}_{rc} \left(\frac{C_c}{1-C_c} \right) + C_s \dot{m}_{rls} \quad (11-9)$$

11.3.13 From the conservation of mass, the total refrigerant mass flow rate \dot{m}_{rt} is equal to the sum of the refrigerant mass flow rate through the calorimeter \dot{m}_{rc} and the refrigerant mass flow rate through the auxiliary lubricant separator \dot{m}_{rs} .

$$\dot{m}_{rt} = \dot{m}_{rc} + \dot{m}_{rs} \quad (11-10)$$

11.3.14 Equation 11-11 is obtained by substituting Equation 11-5 into Equation 11-10.

$$\dot{m}_{rt} = \dot{m}_{rc} + \dot{m}_{rls}(1 - C_s) \quad (11-11)$$

11.3.15 The lubricant circulation rate for the UUT is provided in Equation 11-1.

$$C_{suut} = \frac{\dot{m}_{lt}}{(\dot{m}_{rt} + \dot{m}_{lt})} \times 100 \text{ percent} \quad (11-12)$$

11.3.16 Equation 11-13 is obtained by substituting Equation 11-9 and Equation 11-11 into Equation 11-12.

$$C_{suut} = \left\{ \frac{\dot{m}_{rc} \left(\frac{C_c}{1-C_c} \right) + C_s \dot{m}_{rls}}{\dot{m}_{rc} \left(1 + \left(\frac{C_c}{1-C_c} \right) \right) + \dot{m}_{rls}} \right\} \times 100 \text{ percent} \quad (11-13)$$

12. UNCERTAINTY REQUIREMENTS

12.1 Uncertainty Estimate. An estimate of the measurement uncertainty, performed in accordance with ASME PTC 19.1⁸, shall accompany each refrigerant mass flow measurement.

Informative Note: This procedure is illustrated in the uncertainty examples provided in Informative Annexes B, C, and D.

12.2 Method to Express Uncertainty. All assumptions, parameters, and calculations used in estimating uncertainty shall be clearly documented prior to expressing any uncertainty values. Uncertainty shall be expressed as:

$$v = \bar{X}_m \pm U_{\bar{X}} (P\%)$$

where

v = the variable that is a measurement or a calculated result

\bar{X}_m = the best estimate of the true value

$U_{\bar{X}}$ = the uncertainty estimate for the variable

P = the confidence level, %

Informative Note: For example: refrigerant mass flow rate = 2.538 kg/s \pm 0.013 kg/s (5.595 lb_m/s \pm 0.029 lb_m/s); 95% states that the measured refrigerant mass flow is believed to be 2.538 kg/s (5.595 lb_m/s) with a 95% probability that the true value lies within \pm 0.013 kg/s (\pm 0.029 lb_m/s) of this value.

13. TEST REPORT

If the test plan in Section 5.1 defines the test report requirements, the test report requirements in the test plan supersedes all of the requirements in Section 13. Otherwise, Section 13 specifies the test report requirements.

13.1 Test Identification

- a. Date, place, and time.
- b. Operator.

13.2 Unit Under Test Description

- a. Model number and serial number.
- b. Refrigerant number per ASHRAE Standard 15³.
- c. Source of refrigerant thermodynamic property data.
- d. Lubricant identification and quantity.

13.3 Calorimeter Description and Instrument Descriptions

- a. Calorimeter type.
- b. Model number and serial number.
- c. Operating range classification.
- d. Instrument accuracy based on specifications or calibration.
- e. Documentational evidence of instrument calibrations.

13.4 Measurement System Description

- a. Description of instrument installation specifics.
- b. Measurement system accuracy based on specifications or calibration.
- c. Documentational evidence of calibration in accordance with Section 6.

13.5 Test Conditions

- a. Test conditions in accordance with the test plan in Section 5.1
- b. Ambient temperature, °C (°F).
- c. Barometric pressure Pa, (psia) if pressures instruments are measuring gauge pressure.

13.6 Test Results

- a. Refrigerant mass flow rate, kg/s (lb_m/h).
- b. Compressor input power, W (W), if required by the test plan in Section 5.1.
- c. Uncertainty in refrigerant mass flow rate, kg/s (lb_m/h).

- d. Lubricant circulation rate through the calorimeter, percent by mass.

14. REFERENCES

1. NIST Standard Reference Database 23: *NIST Reference Fluid Thermodynamic and Transport Properties Database (REFPROP) Version 10*. National Institute of Standards and Technology, Gaithersburg, MD.
2. ANSI/ASHRAE Standard 41.11-2020, *Standard Methods for Power Measurement*. Atlanta: ASHRAE. See Note 1.
3. ANSI/ASHRAE Standard 15-2019, *Safety Standard for Refrigeration Systems and Addenda*. Atlanta: ASHRAE.
4. ANSI/ASHRAE Standard 41.1-2020, *Standard Methods for Temperature Measurement*. Atlanta: ASHRAE.
5. ANSI/ASHRAE Standard 41.3-2014, *Standard Methods for Pressure Measurement*. Atlanta: ASHRAE.
6. ANSI/ASHRAE Standard 41.4-2015, *Standard Methods for Measurement of Proportion for Lubricant in Liquid Refrigerant*, Atlanta: ASHRAE. See Note 2.
7. ANSI/ASHRAE Standard 41.8-2015 (R2018), *Standard Methods for Liquid Flow Measurement*. Atlanta: ASHRAE. See Note 3.
8. ASME PTC 19.1-2018, *Test Uncertainty*. ASME, New York, NY.

Informative Notes:

1. Reference 2 is only required if compressor input power measurements are required in the test plan in Section 5.1
2. Reference 6 is only required if lubricant concentration measurements are required.
3. Reference 7 is only required (a) if liquid coolant mass flow rate measurements are required by the test plan, or (b) if an auxiliary lubricant separator is used.

(This annex is not part of this standard. It is merely informative and does not contain requirements necessary for conformance to the standard. It has not been processed according to the ANSI requirements for a standard and may contain material that has not been subject to public review or a consensus process. Unresolved objectors on informative material are not offered the right to appeal at ASHRAE or ANSI.)

INFORMATIVE ANNEX A: FRAMEWORK FOR UNCERTAINTY ANALYSIS FOR A PRIMARY REFRIGERANT CALORIMETER AND A SECONDARY FLUID REFRIGERANT CALORIMETER

A1. This example uses ASME PTC 19.1⁸ to establish a framework for estimating the systematic standard uncertainty b_r of the refrigerant mass flow for a primary refrigerant calorimeter that uses an electrical heat source and for a secondary fluid calorimeter that uses a liquid or vapor heat source where the result R is a function of independent parameters. For this example, $b_r = \Delta\dot{m}$ and $R = \dot{m}$. The parameter descriptions for this example are shown in Table A-1.

Table A-1 Parameter Description for this Example

Parameter	Description	Units
\dot{m}	Refrigerant mass flow rate	kg/h (lb _m /h)
Q_h	Measured calorimeter heat input	kW (Btu/h)
Q_a	Calorimeter heat leakage	kW (Btu/h)
P_2	Pressure of refrigerant vapor at calorimeter outlet	kPa (psia)
T_2	Temperature of refrigerant vapor at calorimeter outlet	°C (°F)
T_4	Temperature of liquid refrigerant entering the refrigerant control device	°C (°F)
h_4	Enthalpy of liquid refrigerant entering the refrigerant control device	kJ/kg (Btu/lb _m)
h_2	Enthalpy of enthalpy of refrigerant vapor exiting the calorimeter	kJ/kg (Btu/lb _m)

The independent parameters are found by starting with the energy equation for an evaporative-type calorimeter:

$$Q_c = \dot{m}(h_2 - h_4)$$

solve for \dot{m} :

$$\dot{m} = \frac{Q_c}{(h_2 - h_4)}$$

where:

$$Q_c = Q_h + Q_a$$

generally:

$$\dot{m} = f(Q_h, Q_a, P_2, T_2, T_4)$$

Contribution of each parameter is defined as the systematic standard uncertainty of the parameter $\Delta(\)$ multiplied by the sensitivity coefficient $\frac{\partial \dot{m}}{\partial(\)}$ and squared per ASME PTC 19.1⁸.

Applying the uncertainty equation yields:

$$\Delta \dot{m} = \left[\left(\Delta Q_h \times \frac{\partial \dot{m}}{\partial Q_h} \right)^2 + \left(\Delta Q_a \times \frac{\partial \dot{m}}{\partial Q_a} \right)^2 + \left(\Delta P_2 \times \frac{\partial \dot{m}}{\partial P_2} \right)^2 + \left(\Delta T_2 \times \frac{\partial \dot{m}}{\partial T_2} \right)^2 + \left(\Delta T_4 \times \frac{\partial \dot{m}}{\partial T_4} \right)^2 \right]^{1/2}$$

Contributions from the heat input and leakage are derived analytically:

$$\Delta Q_h \times \frac{\partial \dot{m}}{\partial Q_h} = \Delta Q_h \times \frac{1}{h_2 - h_4} = \frac{\Delta Q_h}{h_2 - h_4}$$

$$\Delta Q_a \times \frac{\partial \dot{m}}{\partial Q_a} = \Delta Q_a \times \frac{1}{h_2 - h_4} = \frac{\Delta Q_a}{h_2 - h_4}$$

Contributions from the enthalpy terms are dependent on the temperature and pressure and are related by the chain rule analytically and evaluated numerically.

$$\Delta P_2 \times \frac{\partial \dot{m}}{\partial P_2} = \Delta P_2 \times \frac{\partial \dot{m}}{\partial h_2} \times \frac{\partial h_2}{\partial P_2} = \frac{\Delta P_2 \times Q_c}{(h_2 - h_4)^2} \times \frac{\partial h_2}{\partial P_2} = \frac{\Delta P_2 \times Q_c}{(h_2 - h_4)^2} \times \frac{\Delta h_2}{\Delta P_2} \Big|_{T_2}$$

$$\Delta T_2 \times \frac{\partial \dot{m}}{\partial T_2} = \Delta T_2 \times \frac{\partial \dot{m}}{\partial h_2} \times \frac{\partial h_2}{\partial T_2} = \frac{\Delta T_2 \times Q_c}{(h_2 - h_4)^2} \times \frac{\partial h_2}{\partial T_2} = \frac{\Delta T_2 \times Q_c}{(h_2 - h_4)^2} \times \frac{\Delta h_2}{\Delta T_2} \Big|_{P_2}$$

$$\Delta T_4 \times \frac{\partial \dot{m}}{\partial T_4} = \Delta T_4 \times \frac{\partial \dot{m}}{\partial h_1} \times \frac{\partial h_1}{\partial T_4} = \frac{\Delta T_4 \times Q_c}{(h_2 - h_4)^2} \times \frac{\partial h_1}{\partial T_4} = \frac{\Delta T_4 \times Q_c}{(h_2 - h_4)^2} \times \frac{\Delta h_1}{\Delta T_4} \Big|_{P_4}$$

Substituting back into the uncertainty equation:

$$\Delta \dot{m} = \left[\left(\frac{\Delta Q_h}{h_2 - h_4} \right)^2 + \left(\frac{\Delta Q_a}{h_2 - h_4} \right)^2 + \left(\frac{\Delta P_2 \times Q_c}{(h_2 - h_4)^2} \times \frac{\Delta h_2}{\Delta P_2} \Big|_{T_2} \right)^2 + \left(\frac{\Delta T_2 \times Q_c}{(h_2 - h_4)^2} \times \frac{\Delta h_2}{\Delta T_2} \Big|_{P_2} \right)^2 + \left(\frac{\Delta T_4 \times Q_c}{(h_2 - h_4)^2} \times \frac{\Delta h_1}{\Delta T_4} \Big|_{P_4} \right)^2 \right]^{1/2}$$

TABLE A-2 Uncertainty Parameter Description for this Example

Parameter	Description	Units
$\Delta\dot{m}$	Refrigerant mass flow rate	kg/s (lb _m /h)
ΔQ_h	Measured calorimeter heat input	kW (Btu/h)
ΔQ_a	Calorimeter heat leakage	kW (Btu/h)
ΔP_2	Pressure of refrigerant vapor at calorimeter outlet	kPa (psia)
ΔT_2	Temperature of refrigerant vapor at calorimeter outlet	°C (°F)
ΔT_4	Temperature of liquid refrigerant entering the refrigerant control device	°C (°F)
$\left. \frac{\Delta h_2}{\Delta P_2} \right _{T_2}$	Sensitivity of the refrigerant vapor enthalpy exiting the calorimeter with respect to pressure at constant temperature T_2	kJ/kg-kPa (Btu/lb _m -psia)
$\left. \frac{\Delta h_2}{\Delta T_2} \right _{P_2}$	Sensitivity of the refrigerant vapor enthalpy exiting the calorimeter with respect to temperature at constant pressure P_2	kJ/kg-°C (Btu/lb _m -°F)
$\left. \frac{\Delta h_4}{\Delta T_4} \right _{P_4}$	Sensitivity of the refrigerant liquid enthalpy entering the refrigerant control device with respect to temperature at constant pressure P_4	kJ/kg-°C (Btu/lb _m -°F)

Comments

1. The uncertainties in the measured values Q_c , P_2 , T_2 , and T_4 must be estimated for the instrument (or instrumentation system) used to make the measurements. Normally, the measurement error will have two components: (1) the systematic or fixed errors which can be eliminated by calibration, and (2) the random or precision errors associated with the statistical uncertainty of the measurement. The following guidelines can be used to estimate the uncertainties in the measurements, lacking better information:
 - a. The random error can be as much as 50% of the stated instrument accuracy (usually expressed as a percentage of full scale).
 - b. Random errors may be associated with the ability to resolve a reading from the instrument. The random error estimate determined in a measurement shall be compared with the least scale division for reading the instrument. A good rule-of-thumb is to resolve a reading no better than one half the least scale division. This value can then be used to estimate the uncertainty of the instrument reading provided the instrument is accurate enough to make such a measurement.
 - c. The larger estimate of instrument uncertainty, as determined in items a or b, shall be used in the estimate of the error propagation for the mass flow determination.

- d. Alternatively, a more rigorous approach to estimating the random errors can be performed using the statistical methods outlined in ASME PTC 19.1⁸
2. For a primary refrigerant calorimeter that uses electrical energy as the heat source, the wattage measurement plus any heat leakage effects are used to determine Q_c . In this case, ΔQ_h is estimated as described in Comment 1. However, for a secondary fluid calorimeter that uses liquid or vapor as a heat source requires a calculation of Q_c based on measurements having uncertainties.

$$Q_c = \dot{m}c_p(T_2 - T_4)$$

$$T_d = (T_2 - T_4)$$

$$Q_c = \dot{m}c_pT_d$$

Here there are two independent variables, \dot{m} and T_d ; T_1 , dependent upon the relationship of \dot{m} and T_2 . Calculation of the uncertainty, ΔQ_{c_p} , using the procedure in ASME PTC 19.1⁸ gives:

$$\Delta Q_{c_p} = \left\{ \left(\left(\frac{\partial Q_{c_p}}{\partial \dot{m}} \right) (\Delta \dot{m}) \right)^2 + \left(\frac{\partial Q_{c_p}}{\partial T_d} \right)^2 \right\}^{1/2}$$

$$\Delta Q_{c_p} = \left\{ \left(c_p(T_2 - T_4)(\Delta \dot{m}) \right)^2 + \left((c_p \times \dot{m})(T_2 - T_4) \right)^2 \right\}^{1/2}$$

where:

c_p = constant pressure specific heat of the fluid, kJ/kg-°C, (Btu/lb_m-°F)

T_d = temperature difference between exiting secondary fluid and entering secondary fluid, °C (°F)

\dot{m} = mass flow rate of the secondary fluid, kg/s (lb_m/h)

$\Delta \dot{m}$ = uncertainty estimate for the mass flow measurement, kg/s, (lb_m/h)

ΔT = uncertainty estimate for the temperature measurement, °C (°F)

3. $\left. \frac{\partial h_2}{\partial P_2} \right|_T$ = is illustrated as shown on Figure A-1.

It can easily be derived by inspection from the superheated refrigerant tables.

As can be seen from Figure A-1,

$$\left. \frac{\partial h_2}{\partial P_2} \right|_T \rightarrow 0$$

for low values of P but becomes more significant as P approaches the critical pressure.

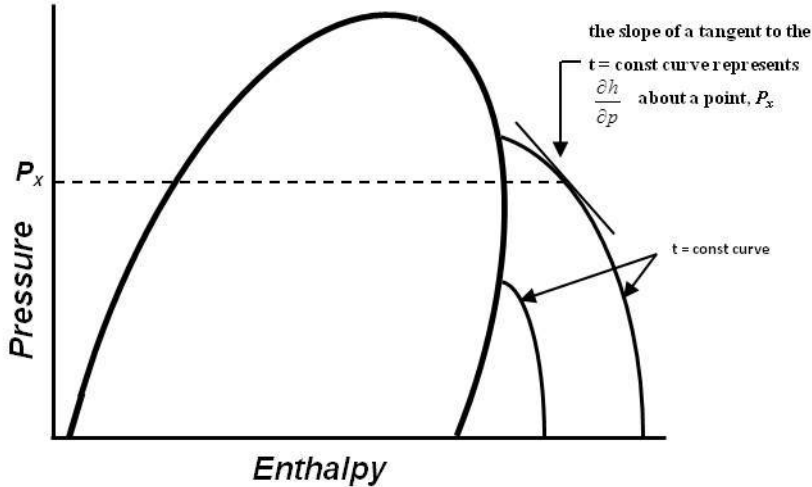

FIGURE A-1 Refrigerant Pressure-Enthalpy Diagram

(This annex is not part of this standard. It is merely informative and does not contain requirements necessary for conformance to the standard. It has not been processed according to the ANSI requirements for a standard and may contain material that has not been subject to public review or a consensus process. Unresolved objectors on informative material are not offered the right to appeal at ASHRAE or ANSI.)

INFORMATIVE ANNEX B: EXAMPLE OF UNCERTAINTY ESTIMATE FOR A SECONDARY REFRIGERANT CALORIMETER

B1. The refrigerant used in this example is R-134a. The refrigerant mass flow rate and uncertainty for this measurement are computed for the test data provided in Table B-1. Systematic standard uncertainty of a result is calculated using ASME PTC 19.1 (b_r)⁸. The accuracies listed in the table were determined by calibrations using standards traceable to NIST.

Table B-1 Test Data for this Example

Parameter	Parameter Description	Value	Accuracy
P_2	Pressure of refrigerant vapor at calorimeter outlet	377.4 kPa (54.73 psia)	± 0.2% (± 0.2%)
T_2	Temperature of refrigerant vapor at calorimeter outlet	18.4 °C (65.1 °F)	± 0.11 °C (± 0.2 °F)
P_4	Pressure of liquid refrigerant entering the refrigerant control device	1,442 kPa (206.2 psia)	± 0.2% (± 0.2%)
T_4	Temperature of liquid refrigerant entering the refrigerant control device	40.8 °C (105.5 °F)	± 0.28 °C (± 0.5 °F)
Q_h	Heat input into calorimeter	36 kW (122,832 Btu/h)	± 0.5% (± 0.5%)
Q_a	Calorimeter heat leakage	1 kW (3,412 Btu/h)	± 0.2% (± 0.2%)

The refrigerant mass flow for a secondary refrigerant calorimeter is given by:

$$\dot{m} = \frac{(Q_c)}{(h_2 - h_4)}$$

where:

$$Q_c = (Q_h + Q_a)$$

and:

$$Q_a = AU_a(T_c - T_a)$$

The refrigerant properties were obtained from the *REFPROP*¹. The condensing temperature corresponding to P_4 is 53°C (127.5°F). Consequently, the subcooling was 12.2°C (22°F), which satisfies the subcooling requirement [at least 5.6°C (10°F)].

Similarly, the evaporating temperature corresponding to P_2 is 7.2°C (45°F). Consequently, the superheating was 11.2°C (20.1°F), which satisfies the superheating requirement [at least 2.8°C (5°F)].

Table B-2 Enthalpy data for this example

Parameter	Parameter Description	Value
h_2	Enthalpy at evaporator calorimeter outlet	264.5 kJ/kg (113.78 Btu/lb _m)
h_4	Enthalpy of liquid refrigerant entering the refrigerant control device	108.9 kJ/kg (46.87 Btu/lb _m)
$(h_2 - h_4)$	Enthalpy difference	155.6 kJ/kg (66.91 Btu/lb _m)

for:

$$Q_c = (Q_h + Q_a) = 37 \text{ kW} \left(126,244 \frac{\text{Btu}}{\text{h}}\right)$$

then:

$$\dot{m} = \frac{Q_c}{h_2 - h_4} = \frac{37 \text{ kW}}{155.6 \text{ kJ/kg}} = 0.238 \frac{\text{kg}}{\text{s}} = 856.0 \frac{\text{kg}}{\text{h}} \left(1887 \frac{\text{lb}_m}{\text{h}}\right)$$

and

$$\dot{m} = f(Q_h, Q_a, P_2, T_2, T_4)$$

Applying the uncertainty equation in ASME PTC 19.1⁸ yields:

$$\Delta \dot{m} = \left[\left(\Delta Q_h \times \frac{\partial \dot{m}}{\partial Q_h} \right)^2 + \left(\Delta Q_a \times \frac{\partial \dot{m}}{\partial Q_a} \right)^2 + \left(\Delta P_2 \times \frac{\partial \dot{m}}{\partial P_2} \right)^2 + \left(\Delta T_2 \times \frac{\partial \dot{m}}{\partial T_2} \right)^2 + \left(\Delta T_4 \times \frac{\partial \dot{m}}{\partial T_4} \right)^2 \right]^{1/2}$$

which leads to:

$$\Delta \dot{m} = \left[\left(\frac{\Delta Q_h}{h_2 - h_4} \right)^2 + \left(\frac{\Delta Q_a}{h_2 - h_4} \right)^2 + \left(\frac{\Delta P_2 \times Q_c}{(h_2 - h_4)^2} \times \frac{\Delta h_2}{\Delta P_2} \Big|_{T_2} \right)^2 + \left(\frac{\Delta T_2 \times Q_c}{(h_2 - h_4)^2} \times \frac{\Delta h_2}{\Delta T_2} \Big|_{P_2} \right)^2 + \left(\frac{\Delta T_4 \times Q_c}{(h_2 - h_4)^2} \times \frac{\Delta h_4}{\Delta T_4} \Big|_{P_4} \right)^2 \right]^{1/2}$$

For this example, assume random errors are 50% of the stated instrument accuracy. For the uncertainties in the heat input and the heat leakage, the precision error was assumed to be 50% of the total error.

$$\Delta Q_h = (36)(\pm 0.5\%)(0.5) = \pm 0.09 \text{ kW} \left(\pm 307 \frac{\text{Btu}}{\text{h}} \right)$$

$$\Delta Q_a = (1)(\pm 0.2)(0.5) = \pm 0.001 \text{ kW } (\pm 3.4 \frac{\text{Btu}}{\text{h}})$$

$$\Delta P_2 = (377.4)(\pm 0.2\%)(0.5) = \pm 0.377 \text{ kPa } (\pm 0.0547 \text{ psia})$$

$$\Delta T_2 = \pm 0.11 \text{ }^\circ\text{C } (\pm 0.2 \text{ }^\circ\text{F})$$

$$\Delta T_4 = \pm 0.28 \text{ }^\circ\text{C } (\pm 0.5 \text{ }^\circ\text{F})$$

Sensitivities for the enthalpies were determined at $\pm 0.6^\circ\text{C}$ ($\pm 1^\circ\text{F}$) of the actual temperature at constant pressure and solved numerically.

$$\left. \frac{\Delta h_2}{\Delta P_2} \right|_{T_2} = \frac{(264.49 - 264.72)}{(384.26 - 370.47)} = -0.017 \frac{\text{kJ}}{\text{kg} - \text{kPa}} \left[-0.050 \frac{\text{Btu}}{\text{lb}_m - \text{psia}} \right]$$

$$\left. \frac{\Delta h_2}{\Delta T_2} \right|_{P_2} = \frac{(265.16 - 264.14)}{(18.9 - 17.8)} = -0.927 \frac{\text{kJ}}{\text{kg} - ^\circ\text{C}} \left[-0.220 \frac{\text{Btu}}{\text{lb}_m - ^\circ\text{F}} \right]$$

$$\left. \frac{\Delta h_4}{\Delta T_4} \right|_{P_4} = \frac{(109.86 - 108.18)}{(41.4 - 40.3)} = 1.527 \frac{\text{kJ}}{\text{kg} - ^\circ\text{C}} \left[0.360 \frac{\text{Btu}}{\text{lb}_m - ^\circ\text{F}} \right]$$

Substituting these values into the refrigerant mass flow uncertainty equation gives:

$$\Delta \dot{m} = \left\{ \left[\frac{(0.09)}{155.6} \right]^2 + \left[\frac{0.001}{155.6} \right]^2 + \left[\frac{(-0.377)(37)(-0.017)}{155.6^2} \right]^2 + \left[\frac{(-0.11)(37)(-0.927)}{155.6^2} \right]^2 + \left[\frac{(0.28)(37)(1.527)}{155.6^2} \right]^2 \right\}^{1/2}$$

$$\Delta \dot{m} = [(3.35 \times 10^{-7}) + (4.13 \times 10^{-11}) + (9.59 \times 10^{-11}) + (2.4 \times 10^{-8}) + (4.27 \times 10^{-7})]^{1/2}$$

$$\Delta \dot{m} = (7.86 \times 10^{-7})^{0.5} = 8.86 \times 10^{-4} \frac{\text{kg}}{\text{s}} = 3.19 \frac{\text{kg}}{\text{h}} (7.033 \frac{\text{lb}}{\text{h}})$$

which is 0.37% of the calculated refrigerant mass flow rate. Consequently, the result is:

$$\Delta \dot{m} = 855.8 \pm 3.19 \frac{\text{kg}}{\text{h}} (1887 \pm 7.033 \frac{\text{lb}}{\text{h}})$$

and the actual refrigerant mass flow rate has a 95% certainty of being between 852.61 and 858.99 kg/h (1880.0 and 1894.0 lb_m/h).

Looking at the uncertainty contribution of each term in the $\Delta \dot{m}$ equation by dividing each by the total:

$$Q_h \text{ term} = \frac{(3.35 \times 10^{-7})^2}{(7.86 \times 10^{-7})^{0.5}} \cdot 100 = 42.62$$

similarly:

$$Q_a \text{ term} = 0.005\%$$

$$P_2 \text{ term} = 0.01\%$$

$$T_2 \text{ term} = 3.05\%$$

$$T_4 \text{ term} = 54.32\%$$

It is apparent that most of the error results from the heat input measurement, Q_h , and the liquid refrigerant temperature measurement, T_4 . If the T_4 error was reduced to match the T_2 error $\pm 0.11^\circ\text{C}$ ($\pm 0.2^\circ\text{F}$), the uncertainty in the refrigerant mass flow rate would be reduced from $\pm 3.19 \text{ kg/h}$ ($\pm 7.033 \text{ lb}_m/\text{h}$) to $\pm 2.344 \text{ kg/h}$ ($\pm 5.169 \text{ lb}_m/\text{h}$), which can also be expressed as a reduction from $\pm 0.37\%$ to $\pm 0.27\%$.

Similarly, if the uncertainty in the heat input measurement was reduced to $\pm 0.25\%$ in addition to replacing the T_4 sensor with one as precise as the T_2 sensor, the uncertainty in the refrigerant mass flow rate would be reduced to $\pm 1.50 \text{ kg/h}$ ($\pm 3.306 \text{ lb}_m/\text{h}$) or $\pm 0.18\%$.

(This annex is not part of this standard. It is merely informative and does not contain requirements necessary for conformance to the standard. It has not been processed according to the ANSI requirements for a standard and may contain material that has not been subject to public review or a consensus process. Unresolved objectors on informative material are not offered the right to appeal at ASHRAE or ANSI.)

INFORMATIVE ANNEX C: EXAMPLE OF UNCERTAINTY ESTIMATE FOR A CONDENSER CALORIMETER

C1. In this example, a condenser calorimeter is used to provide a confirming mass flow measurement for the test in the previous example (Informative Annex B). The refrigerant used in this example is R-134a. The refrigerant mass flow rate and uncertainty for this measurement are computed for the test data and measurement accuracies provided in Table C-1.

Table C-1 Test Data for this Example

Parameter	Description	Value	Accuracies
P_3	Pressure of refrigerant vapor at calorimeter inlet	1,498 kPa (217.3 psia)	± 8.62 kPa (± 1.25 psia)
T_3	Temperature of refrigerant vapor at calorimeter inlet	77.1 °C (170.8 °F)	± 0.28 °C (± 0.5 °F)
P_4	Pressure of refrigerant liquid at calorimeter outlet	1,428 kPa (207.1 psia)	± 8.62 kPa (± 1.25 psia)
T_4	Temperature of refrigerant liquid at calorimeter outlet	41.4 °C (106.5 °F)	± 0.28 °C (± 0.5 °F)
T_{w1}	Temperature of water entering the calorimeter	28.7 °C (83.7 °F)	± 0.28 °C (± 0.5 °F)
T_{w2}	Temperature of water exiting the calorimeter	31.4 °C (88.5 °F)	± 0.28 °C (± 0.5 °F)
\dot{m}_w	Mass flow rate of water entering the calorimeter	14,728 kg/h (32,470 lb _m /h)	± 147 kg/h (± 324 lb _m /h)
Q_a	Heat leakage determined for the calorimeter	234 W (798 Btu/h)	2 W (40 Btu/h)

The accuracies listed in the table were determined by calibrations using standards traceable to NIST as described in Section 6. However, three additional cases are shown, each resulting in improved uncertainty of mass flow measurement.

C2. Baseline Case. The refrigerant mass flow for a condenser calorimeter is determined from Equation (10-2):

$$\dot{m} = \frac{\dot{m}_w c_p (T_{w1} - T_{w2}) + Q_a}{(h_3 - h_4)} \quad (10-2)$$

where

\dot{m} = refrigerant mass flow rate, kg/s (lb_m/h)

\dot{m}_w = single-phase liquid mass flow rate, kg/s (lb_m/h)

- c_p = constant pressure specific heat of single-phase liquid at the average temperature, $(t_{w1} + t_{w2})/2$, kJ/(kg- °C), (Btu/(lb_m- °F))
- T_{w1} = single-phase liquid temperature entering the calorimeter, °C (°F)
- T_{w2} = single-phase liquid temperature exiting the calorimeter, °C (°F)
- Q_a = calorimeter heat leakage, kW (Btu/h)
- h_3 = refrigerant vapor enthalpy entering the calorimeter, kJ/kg (Btu/lb_m)
- h_4 = refrigerant liquid enthalpy exiting the calorimeter, kJ/kg (Btu/lb_m)

The refrigerant properties were obtained from a commercial equation-solver computer program that uses NIST REFPROP¹ as its source. The condensing temperature corresponding to the values p_4 and t_4 is 53.2°C (127.7 °F). Consequently, the liquid subcooling was 11.8°K (21.2°R) which satisfies the subcooling requirement [at least 5.6°K (10°R)].

Similarly, the condensing temperature corresponding to the values of P_3 and T_3 is 55.2°C (131.3°F). Consequently, the inlet superheating was 21.9°K (39.5°R) which satisfies the superheating requirement [at least 2.8°K (5°R)].

The enthalpies for the condenser calorimeter inlet and outlet for this example were:

$$h_3 = 303.5 \text{ kJ/kg (130.5 Btu/lb}_m\text{)}$$

$$h_4 = 110.3 \text{ kJ/kg (47.41 Btu/lb}_m\text{)}$$

so:

$$(h_3 - h_4) = 193.2 \text{ kJ/kg (83.05 Btu/lb)}$$

From Equation 10-2, the refrigerant mass flow rate is

$$\dot{m} = \left[\frac{(14728) \times (4.183) \times (31.4 - 28.7) + (0.234) \times (3600)}{193.2} \right]$$

or:

$$\dot{m} = 865.4 \text{ kg/h (1908 lb}_m\text{/h)}$$

With the assumption that c_p is constant in our range of interest, applying the uncertainty equation from ASME PTC 19.1⁸ yields:

$$\Delta\dot{m} = \pm \left\{ \left[\frac{\Delta\dot{m}_w c_p (T_{w2} - T_{w1})}{(h_3 - h_4)} \right]^2 + \left[\frac{\Delta T_{w2} (\dot{m}_w c_p)}{(h_3 - h_4)} \right]^2 + \left[\frac{\Delta T_{w1} (\dot{m}_w c_p)}{(h_3 - h_4)} \right]^2 + \left[\frac{\Delta Q_a}{h_3 - h_4} \right]^2 \right. \\ \left. + \left[\frac{-\Delta P_3 (\dot{m}_w c_p (T_{w2} - T_{w1}) + Q_a) \left(\frac{\partial h_3}{\partial P_3} \right)}{(h_3 - h_4)^2} \right]^2 + \left[\frac{-\Delta T_3 (\dot{m}_w c_p (T_{w2} - T_{w1}) + Q_a) \left(\frac{\partial h_3}{\partial T_3} \right)}{(h_3 - h_4)^2} \right]^2 \right. \\ \left. + \left[\frac{-\Delta P_4 (\dot{m}_w c_p (T_{w2} - T_{w1}) + Q_a) \left(\frac{\partial h_4}{\partial P_4} \right)}{(h_3 - h_4)^2} \right]^2 + \left[\frac{-\Delta T_4 (\dot{m}_w c_p (T_{w2} - T_{w1}) + Q_a) \left(\frac{\partial h_4}{\partial T_4} \right)}{(h_3 - h_4)^2} \right]^2 \right\}^{0.5}$$

The uncertainties for the enthalpy values are dependent on pressure and temperature measurements p_3 , t_3 , and t_4 , as follows:

$$\left. \frac{\partial h_3}{\partial P_3} \right|_{T=170.8} = \frac{(303.467 - 303.455)}{(1498.0 - 1498.69)} \\ = -0.0171 \text{ kJ/kg-kPa} \\ = -0.0506 \text{ Btu/(lb}_m\text{-psia)}$$

$$\left. \frac{\partial h_3}{\partial T_3} \right|_{P=217.2} = \frac{(303.467 - 303.531)}{(77.10 - 77.16)} \\ = 1.142 \text{ kJ/kg-}^\circ\text{C} \\ = 0.273 \text{ Btu/(lb}_m\text{-}^\circ\text{F)}$$

$$\left. \frac{\partial h_4}{\partial P_4} \right|_{T=106.5} = \frac{(110.28 - 110.28)}{(1428.0 - 1428.69)} \\ = -0.0002 \text{ kJ/kg-kPa} \\ = -0.0006 \text{ Btu/(lb}_m\text{-}^\circ\text{F)}$$

$$\left. \frac{\partial h_4}{\partial T_4} \right|_{P=207.1} = \frac{(110.28 - 110.37)}{(41.40 - 41.46)} \\ = 1.499 \text{ kJ/kg-}^\circ\text{C} \\ = 0.358 \text{ Btu/(lb}_m\text{-}^\circ\text{F)}$$

Substituting these values into the refrigerant mass flow uncertainty equation gives:

$$\Delta\dot{m} = \{ [(147) (4.183) (2.7)/(193.2)]^2 \\ + [(0.28) (14,728) (4.183)/(193.2)]^2 \\ + [(0.28) (14,728) (4.183)/(193.2)]^2 \\ + [(0.012) (3600)/(193.2)]^2 \\ + [(-8.62) (157,664) (-0.0171)/(193.2)^2]^2 \\ + [(-0.28) (157,664) (1.142)/(193.2)^2]^2 \\ + [(-8.62) (157,664) (-0.0002)/(193.2)^2]^2 \}$$

$$\Delta \dot{m} = (73.85 + 7,972 + 7,972 + 0.050 + 0.388 + 1.824 + 0 + 3.143)^{0.5}$$

$$\Delta \dot{m} = (16,023)^{0.5} = 126.6 \text{ kg/h (276.9 lb}_m\text{/h)}$$

which is 14.5% of the calculated refrigerant mass flow rate. Consequently, the result is:

$$\dot{m} = 865.6 \pm 126.6 \text{ kg/h (1,908} \pm 276.9 \text{ lb}_m\text{/h)}$$

The uncertainty contribution of each term in the $\Delta \dot{m}$ equation is determined by dividing each by the total amount. The results are shown in Table C-1 below:

TABLE C-1 Uncertainty contribution of each term in the $\Delta \dot{m}$ equation for the baseline case

Variable \pm Uncertainty	Partial Derivative	% of Uncertainty
$\dot{m}_w = 14728 \pm 147 \text{ kg/h (32470} \pm 324 \text{ lb}_m\text{/h)}$	$\frac{\partial \dot{m}}{\partial \dot{m}_w} = 0.05846$	0.47%
$P_3 = 1499 \pm 8.7 \text{ kPa (217.3} \pm 1.25 \text{ psia)}$	$\frac{\partial \dot{m}}{\partial P_3} = 1.161$	0.00%
$P_4 = 1428 \pm 8.7 \text{ kPa (207.1} \pm 1.25 \text{ psia)}$	$\frac{\partial \dot{m}}{\partial P_4} = -0.01337$	0.00%
$Q_a = 234 \pm 12 \text{ W (798.4} \pm 40 \text{ Btu/h)}$	$\frac{\partial \dot{m}}{\partial Q_a} = 0.01204$	0.00%
$T_3 = 77.1 \pm 0.3 \text{ }^\circ\text{C (170.8} \pm 0.5 \text{ }^\circ\text{F)}$	$\frac{\partial \dot{m}}{\partial T_3} = -6.266$	0.01%
$T_4 = 41.4 \pm 0.3 \text{ }^\circ\text{C (106.5} \pm 0.5 \text{ }^\circ\text{F)}$	$\frac{\partial \dot{m}}{\partial T_4} = 8.223$	0.02%
$T_{w1} = 28.7 \pm 0.3 \text{ }^\circ\text{C (83.66} \pm 0.5 \text{ }^\circ\text{F)}$	$\frac{\partial \dot{m}}{\partial T_{w1}} = -390.06$	49.75%
$T_{w2} = 31.4 \pm 0.3 \text{ }^\circ\text{C (88.52} \pm 0.5 \text{ }^\circ\text{F)}$	$\frac{\partial \dot{m}}{\partial T_{w2}} = 390.06$	49.75%

C2.1 Second Case. With the original instrumentation, most of the uncertainty (99.5%) occurs as a result of the precision of the temperature sensors for the condenser calorimeter water inlet and outlet measurements. Changing the precision of these two devices to $\pm 0.06^\circ\text{C}$ ($\pm 0.1^\circ\text{F}$) will reduce the uncertainty in the refrigerant mass flow rate to 26.6 kg/h (58.65 lb/h) or 3.1% of the mass flow rate.

To reduce this further, the water mass flow rate can be decreased which increases the water's temperature rise through the calorimeter. If the mass flow is decreased to 3,683 kg/h (8,120 lb_m/h), the mass flow meter's accuracy changes to an absolute 36.8 kg/h (81 lb_m/h) because its accuracy is 1% of reading. The temperature difference increases to 10.9°C (19.6°F) resulting in a calculated uncertainty of 10.91 kg/h (24.1 lb_m/h) or $\pm 1.3\%$.

The resulting uncertainty contribution of each term is provided in Table C-2:

TABLE C-2 Uncertainty contribution of each term in the $\Delta\dot{m}$ equation for the second case

Variable \pm Uncertainty	Partial Derivative	% of Uncertainty
$\dot{m}_w = 3683 \pm 37$ kg/h (8120 \pm 81 lb _m /h)	$\frac{\partial \dot{m}}{\partial \dot{m}_w} = 0.2238$	62.00%
$P_3 = 1499 \pm 8.7$ kPa (217.3 \pm 1.25 psia)	$\frac{\partial \dot{m}}{\partial P_3} = 1.162$	0.36%
$P_4 = 1428 \pm 8.7$ kPa (207.1 \pm 1.25 psia)	$\frac{\partial \dot{m}}{\partial P_4} = -0.01337$	0.00%
$Q_a = 234 \pm 12$ W (798.4 \pm 40 Btu/h)	$\frac{\partial \dot{m}}{\partial Q_a} = 0.01204$	0.04%
$T_3 = 77.1 \pm 0.3$ °C (170.8 \pm 0.5 °F)	$\frac{\partial \dot{m}}{\partial T_3} = -6.267$	1.70%
$T_4 = 41.4 \pm 0.3$ °C (106.5 \pm 0.5 °F)	$\frac{\partial \dot{m}}{\partial T_4} = 8.225$	2.92%
$T_{w1} = 28.7 \pm 0.3$ °C (83.66 \pm 0.1 °F)	$\frac{\partial \dot{m}}{\partial T_{w1}} = -97.69$	16.49%
$T_{w2} = 39.7 \pm 0.05$ °C (103.1 \pm 0.1 °F)	$\frac{\partial \dot{m}}{\partial T_{w2}} = 97.66$	16.48%

C2.2 Third Case. With revised instrumentation precision and a slightly different operating procedure, the major contributor to the total uncertainty is now the water mass flow meter. Changing this meter to one with a precision of $\pm 0.2\%$ of reading [0.2% of 3,683 kg/h (8,120 lb_m/h)] yields a calculated uncertainty for the refrigerant mass flow rate of ± 6.94 kg/h (± 15.3 lb_m/h) or 0.80% with the resulting uncertainty contribution of each term provided in Table C-3:

TABLE C-3 Uncertainty contribution of each term in the $\Delta\dot{m}$ equation for the third case

Variable \pm Uncertainty	Partial Derivative	% of Uncertainty
$\dot{m}_w = 3683 \pm 7.37$ kg/h (8120 \pm 16.24 lb _m /h)	$\frac{\partial \dot{m}}{\partial \dot{m}_w} = 0.2238$	6.16%
$P_3 = 1499 \pm 8.7$ kPa (217.3 \pm 1.25 psia)	$\frac{\partial \dot{m}}{\partial P_3} = 1.162$	0.36%
$P_4 = 1428 \pm 8.7$ kPa (207.1 \pm 1.25 psia)	$\frac{\partial \dot{m}}{\partial P_4} = -0.01337$	0.00%
$Q_a = 234 \pm 12$ W (798.4 \pm 40 Btu/h)	$\frac{\partial \dot{m}}{\partial Q_a} = 0.01204$	0.04%
$T_3 = 77.1 \pm 0.3$ °C (170.8 \pm 0.5 °F)	$\frac{\partial \dot{m}}{\partial T_3} = -6.267$	1.70%
$T_4 = 41.4 \pm 0.3$ °C (106.5 \pm 0.5 °F)	$\frac{\partial \dot{m}}{\partial T_4} = 8.225$	2.92%
$T_{w1} = 28.7 \pm 0.3$ °C (83.66 \pm 0.1 °F)	$\frac{\partial \dot{m}}{\partial T_{w1}} = -97.69$	40.73%
$T_{w2} = 39.7 \pm 0.05$ °C (103.1 \pm 0.1 °F)	$\frac{\partial \dot{m}}{\partial T_{w2}} = 97.66$	40.71%

Now, the majority of the error is again associated with the condenser calorimeter inlet and outlet water temperature measurement devices. Since these devices have already been replaced with ones of greater accuracy, this result can be little improved. The combined standard uncertainty has a 70% certainty of being between 859 and 872 kg/h (1,893 and 1,923 lb_m/h). If the combined standard uncertainty of (± 6.94 kg/h) ± 15.31 lb_m/h is multiplied by a factor of 2, the measured refrigerant mass flow measurement

has a 95% certainty of being between 851 kg/h and 880 kg/h (1,877 and 1,939 lb_m/h) using statistical methods explained in ASME PTC 19.1⁸, which compares favorably with the results in Annex B.

(This annex is not part of this standard. It is merely informative and does not contain requirements necessary for conformance to the standard. It has not been processed according to the ANSI requirements for a standard and may contain material that has not been subject to public review or a consensus process. Unresolved objectors on informative material are not offered the right to appeal at ASHRAE or ANSI.)

INFORMATIVE ANNEX D: SOURCES OF TEMPERATURE MEASUREMENT ERROR

- D1.** Sources of temperature measurement error should be addressed with regard to the sensor type, usage, location, and mounting requirements based on the test plan requirements for test plan accuracy and uncertainty.
- D2.** Sources of measurement error include:
- Sensor probe stem effect
 - Optimum sensor operating temperature accuracy range
 - Poor thermal conductivity of mounting method
 - Lead wire thermal conductivity
 - External radiation effects
 - Self-heating of the sensor element
 - Sensor reaction time constants
 - Sensor calibration procedure
 - Thermal gradient.
- D3.** Thermal gradient effects from the temperature differential of the measured value and the surrounding ambient temperature should be addressed by insulating the temperature probe with a material supplying no less than R4.5.